

SIEMENS

STEP 2000

Basics of Electrical Products

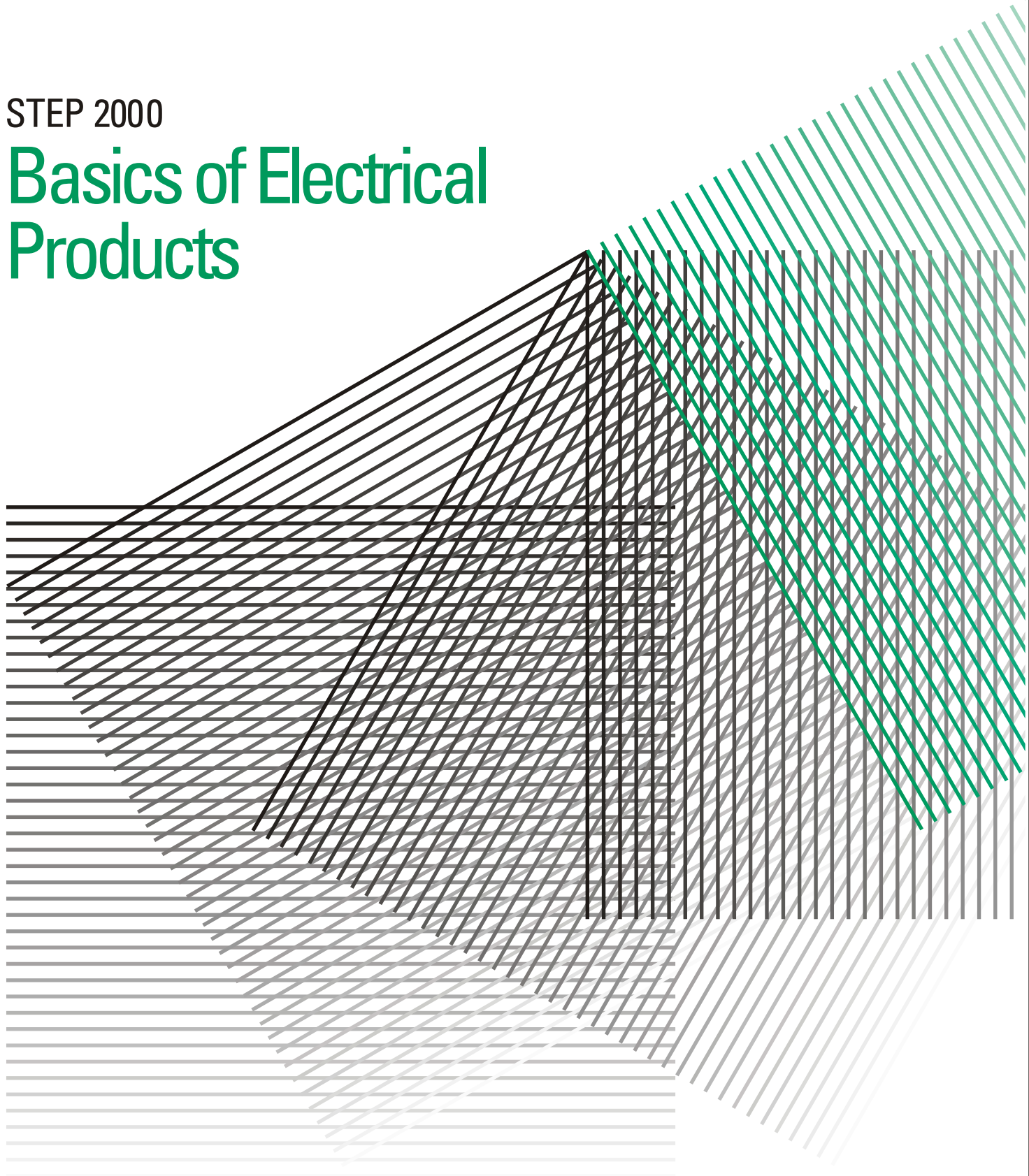

Table of Contents

Introduction	2
Siemens Energy & Automation, Inc.....	4
Electric Power.....	6
Residential Applications.....	11
Commercial Applications	20
Industrial Applications.....	36
Manufacturing Applications	47
Discrete Parts Manufacturing	49
Assembly Processes	56
Batch and Continuous Processes	64
Pictorial Glossary	70
Review Answers.....	118
Final Exam	119

Introduction

Welcome to another course in the STEP 2000 series, **Siemens Technical Education Program**, designed to prepare our distributors to sell Siemens Energy & Automation products more effectively. This course covers **Basics of Electrical Products**.

Upon completion of **Basics of Electrical Products**, you should be able to:

- Explain how power is distributed from a power distribution plant to various residential, commercial, and industrial facilities
- Explain how Siemens products are used in basic residential, commercial, and industrial applications
- Explain the similarities and differences between load centers, panelboards, switchboards, switchgear, and secondary unit substations
- Identify various Siemens products used in discrete parts manufacturing, assembly, batch processing, and continuous processing
- Identify various Siemens products by trade name

This knowledge will help you better understand customer applications. In addition, you will be better prepared to discuss electrical products and systems with customers. You should complete **Basics of Electricity** before attempting **Basics of Electrical Products**. Once you have completed **Basics of Electrical Products**, you should complete or review any of the other STEP 2000 courses that are relevant to your work. The general information provided in **Basics of Electrical Products** will help you better understand the specific product details in the remaining STEP 2000 courses.

If you are an employee of a Siemens Energy & Automation authorized distributor, fill out the final exam tear-out card and mail in the card. We will mail you a certificate of completion if you score a passing grade. Good luck with your efforts.

EQ, instabus, WinCC, SITOP, SINUMERIK, SIMODRIVE, SIMOREG, and SIMATIC are registered trademarks of Siemens Energy & Automation, Inc.

Uni-Pak, Sentron, ACCESS, Super Blue Pennant, Medallion, ESP100, INNOVA PLUS, System 89, and PCS are trademarks of Siemens Energy & Automation, Inc.

National Electrical Code[®] and NEC[®] are registered trademarks of the National Fire Protection Association, Quincy, MA 02269. Portions of the National Electrical Code are reprinted with permission from NFPA 70-2002, National Electrical Code Copyright, 2001, National Fire Protection Association, Quincy, MA 02269. This reprinted material is not the complete and official position of the National Fire Protection Association on the referenced subject which is represented by the standard in its entirety.

Underwriters Laboratories Inc. and UL are registered trademarks of Underwriters Laboratories Inc., Northbrook, IL 60062.

National Electrical Manufacturers Association is located at 2101 L Street, N.W., Washington, D.C. 20037. The abbreviation "NEMA" is understood to mean National Electrical Manufacturers Association.

MS-DOS, Windows, and Windows NT are registered trademarks of Microsoft, Inc.

Other trademarks are the property of their respective owners.

Siemens Energy & Automation, Inc.

Company Overview

Siemens Energy & Automation (SE&A) is one of a number of companies owned by Siemens AG. Siemens AG has its headquarters in Munich, Germany, and is one of the world's largest suppliers of electrical and electronic products, systems, and associated services. Siemens companies operate in the United States under the financial umbrella of Siemens Corporation. These companies sell equipment for use in a vast array of industries and applications.

SE&A sells a broad range of products that are used in residential, commercial, and industrial applications. A generic listing of the products sold by SE&A sales force and authorized distributors is shown below.

- AC Motors, Pumps, and Compressors
- Busway
- Circuit Breakers
- Control Components
- Safety Switches
- Human Machine Interfaces (HMI)
- Industrial Networks
- Industrial Personal Computers
- Load Centers
- Metering
- Motion Controls and Servo Drives
- Motor Control Centers
- Panelboards
- Power Monitoring and Management Systems
- Power Supplies
- Process Automation Systems
- Programmable Logic Controllers (PLCs)
- Radio Frequency Identification System
- Software Solutions
- Switchboards
- Switchgear
- Transformers
- Variable Speed Drives

Key to Understanding SE&A Products

Depending upon your experience with electrical and electronic products, you may find the generic listing to be either unintelligible or straightforward. When this list is expanded into the literally thousands of specific products sold by SE&A, even the most experienced professionals may be dazed by the seeming complexity. As diverse as this product listing would be, however, there are some common concepts.

- These products use electrical power and, in many cases, control the flow of energy to other products or systems.
- These products are most commonly used in residential, commercial, and industrial applications.

In order to help you better understand SE&A products, this course will look at where many of these products fit in the flow of energy in sample residential, commercial, and industrial applications. The flow of energy from the electric utility will be discussed only briefly; however, keep in mind that many of the products listed above are also used by electric utilities. In addition, the products of other Siemens companies, especially Siemens Westinghouse Power Corporation and Siemens Power Transmission & Distribution, are used extensively by these utilities.

By better understanding where electrical products fit in the flow of energy, you can better understand the physical and electrical requirements of these products.

Electric Power

Power, originating at a power generating plant, is distributed to residential, commercial, and industrial customers through various transmission lines and substations.



Power Sources

There are several sources used to produce power. Coal, oil, and uranium are fuels used to convert water into steam which in turn drives a turbine. Some utilities also use gas turbines, or both gas and steam turbines, for combined cycle operation. The output shaft of the turbine is connected to an AC generator. The AC generator is rotated by the turbine. It is the AC generator which converts the mechanical energy into electrical energy.

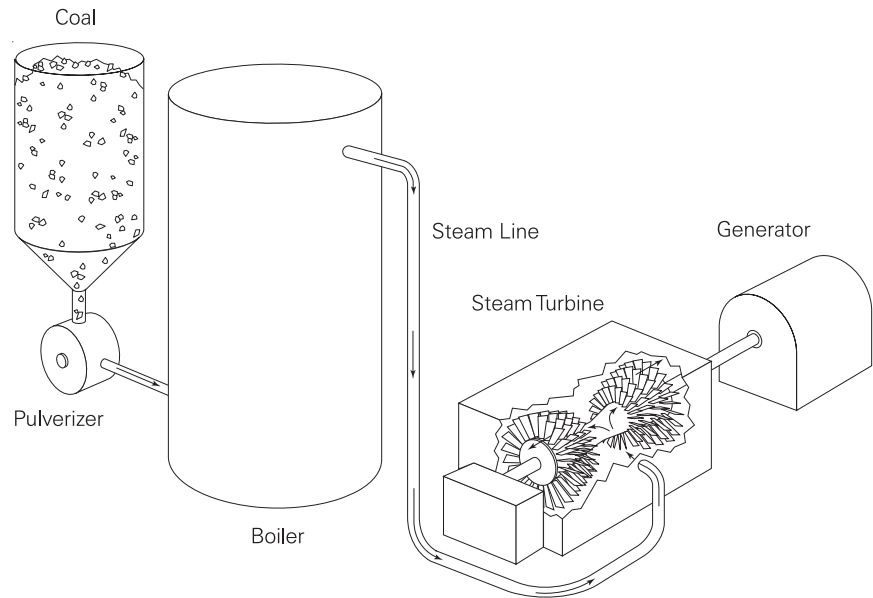

Hydroelectric Power

Hydroelectric power plants use mechanical energy from falling water to turn the turbine.

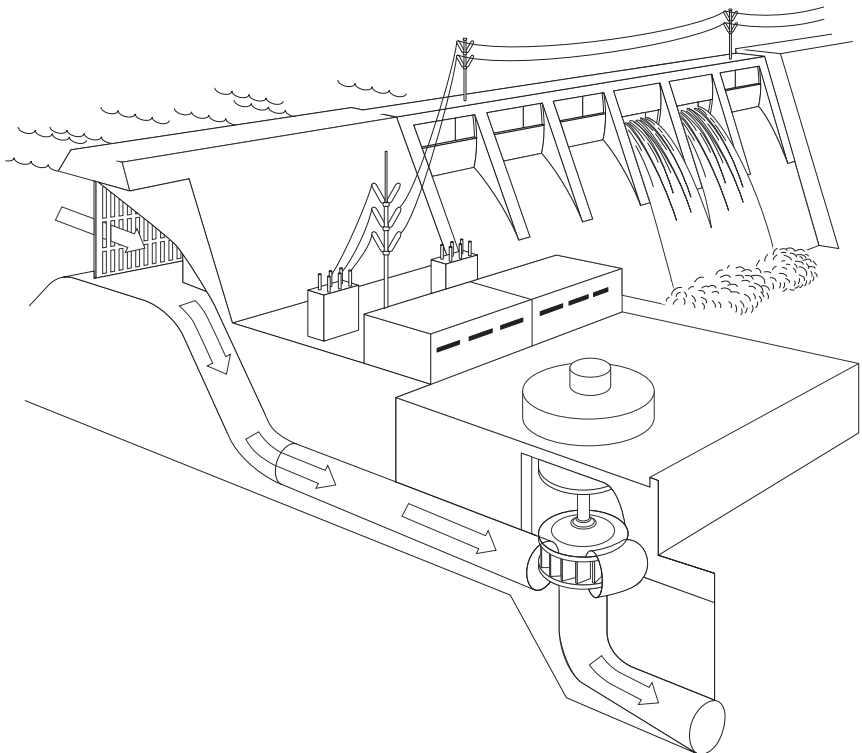

AC Generators

AC generators operate on the theory of electromagnetic induction. This simply means that when conductors are moved through a magnetic field a voltage is induced into the conductors. A basic generator consists of a magnetic field, an armature, slip rings, brushes, and some type of resistive load. An armature is any number of conductive wires (conductors) wound in loops which rotate through the magnetic field. For simplicity, one loop is shown.

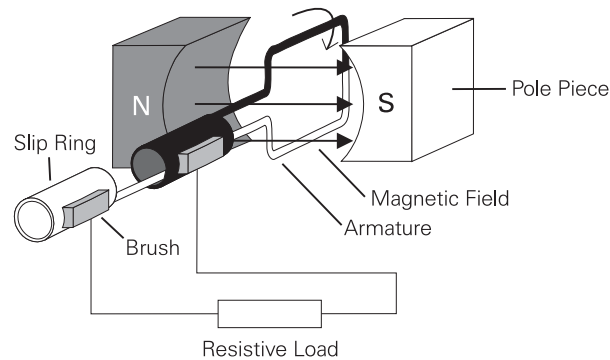

If the rotation of the AC generator were tracked through a complete revolution of 360° , it could be seen that during the first quarter of a revolution voltage would increase until it reached a maximum positive value at 90° . Voltage would decrease during the second quarter of a revolution until it reached zero at 180° . During the third quarter of a revolution, voltage would increase in the opposite direction until it reached a maximum negative value at 270° . During the last quarter of a revolution, voltage would decrease until it reached zero at 360° . This is one complete cycle or one complete alternation between positive and negative. If the armature of the AC generator were rotated 3600 times per minute (RPM) we would get 60 cycles of voltage per second, or 60 hertz.

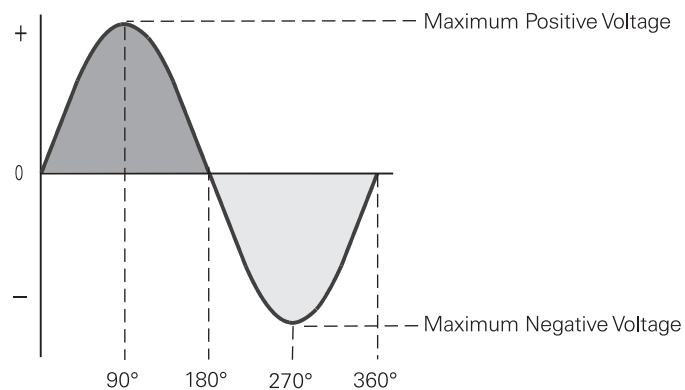

Energy Transfer

The role of the generator just described is to change mechanical energy into electrical energy. In order for this energy to be useful, however, it must be transmitted to the utility's customers via transmission lines. The most efficient way to do this is to increase the voltage while at the same time reducing the current. This is necessary to minimize the energy lost in heat on the transmission lines. These losses are referred to as I^2R (I-squared-R) losses since they are equal to the square of the current times the resistance of the power lines. Once the electrical energy gets near the end user, the utility will need to step down the voltage to the level needed by the user.

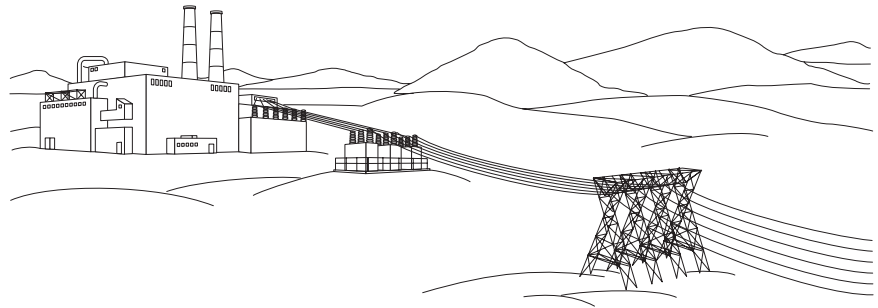

Transformers

The device that utilities use to step up the voltage at the generator end and step down the voltage at the user end is called a transformer. The transformer transfers energy from a primary coil to a secondary coil by mutual induction. The AC generator provides electrical power to the primary coil. The magnetic field produced by the primary coil induces a voltage into the secondary coil which supplies power to the connected load. The load in this case would be the entire electrical distribution network including all residential, commercial, and industrial customers. A step-up transformer is used when it is desirable to step voltage up from one level to another. A 1:2 step-up transformer, for example, would be used to step 120 volts up to 240 volts. A 2:1 step-down transformer would be used to step 240 volts down to 120 volts.

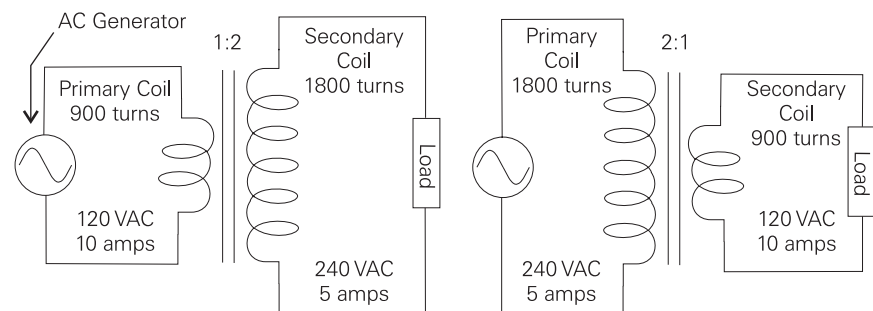

Step-Up Transformer

Step-Down Transformer

Three-Phase Voltage

For simplicity, the generator and transformers shown so far have been single-phase devices. While single-phase power is needed for many applications, utilities generate and transmit three-phase power. In a three-phase system, the generator produces three voltages. Each voltage phase rises and falls at the same frequency (60 Hz in the U.S., 50 Hz in many other countries); however, the phases are offset from each other by 120° .

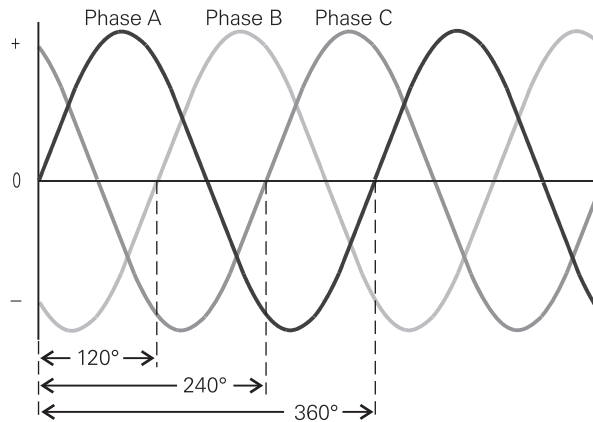

Three-Phase Transformers

Transformers used with three-phase power require three interconnected coils in both the primary and the secondary. These transformers can be connected in either a wye or a delta configuration. The type of transformer and the actual voltage depend on the requirements and capability of the power company and the needs of the customer. The following illustration shows the secondary of a wye-connected transformer and the secondary of a delta-connected transformer.

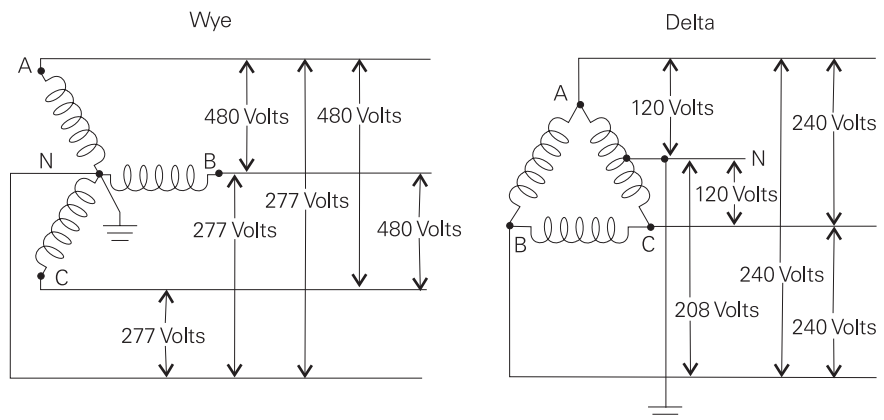

A - B	480 volts
B - C	480 volts
C - A	480 volts
A - N	277 volts
B - N	277 volts
C - N	277 volts

A - B	240 volts
B - C	240 volts
C - A	240 volts
A - N	120 volts
B - N	208 volts
C - N	120 volts

Residential Applications

Power, generated at a power plant, then stepped up to a high transmission voltage is brought to a local substation. Here, it is stepped down to a lower distribution voltage. When it reaches its final destination at a residential customer, it is stepped down to 240 volts. Only single-phase power is used in a typical residential application.

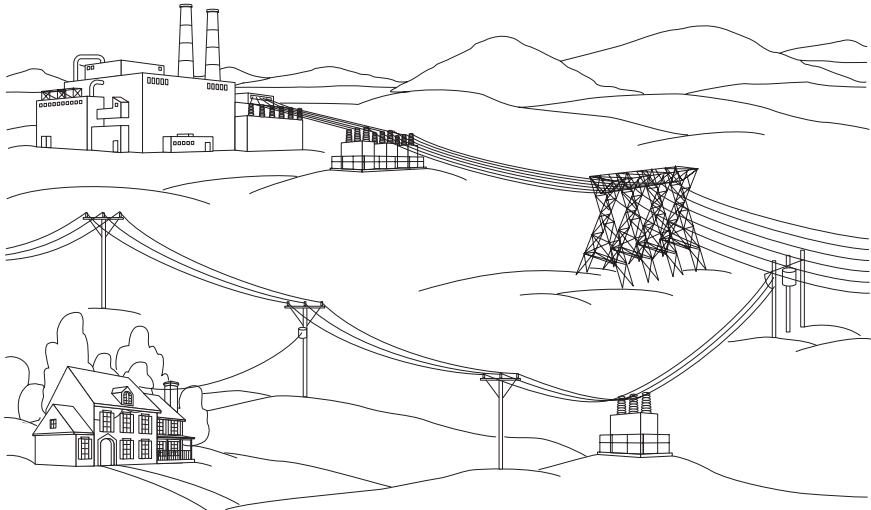

Power Supply

The most common supply system used in residential applications today is a single-phase, three-wire supply system. In this system, there are 120 volts between either hot wire and neutral and 240 volts between the two hot wires. The 120-volt supply is used for general-purpose receptacles and lighting. The 240 volt supply is used for heating, cooling, cooking, and other high-demand loads.

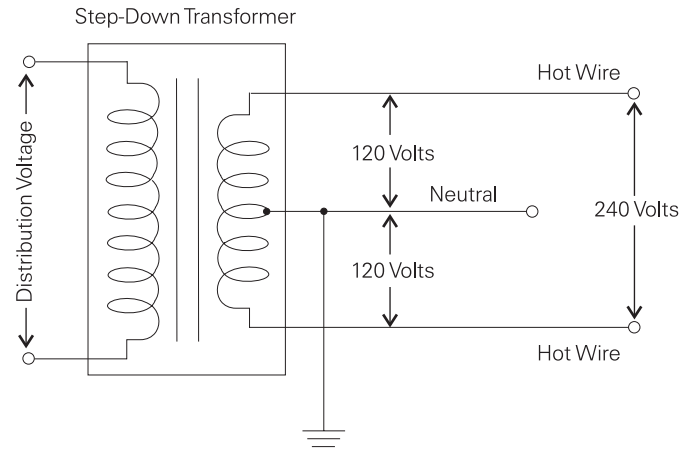

Service Entrance

Power, purchased from a utility company, enters the house through a metering device and connects to a load center. This is the service entrance. Residential service can come from an overhead utility transformer or from a lateral service run underground.

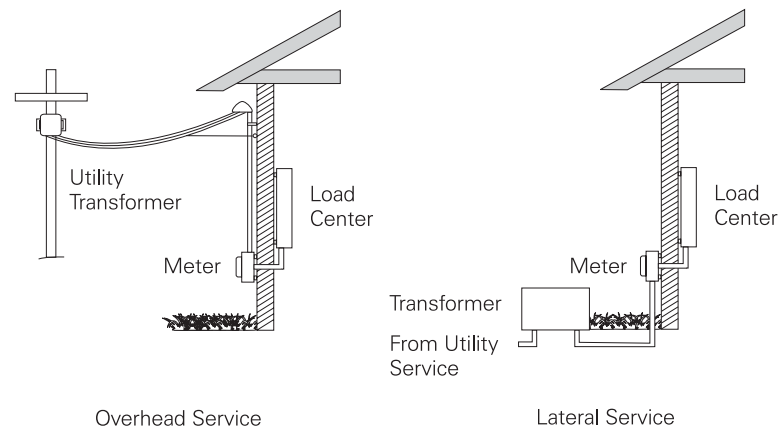

Meter Sockets

Most of us are familiar with the watt-hour meter located outside our homes. The watt-hour meter is used by the power company to determine how much electricity has been consumed for billing purposes. Siemens manufactures single-position meter sockets for residential use.

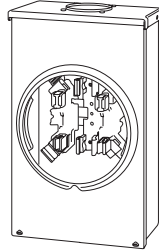

Meter Mains and Meter Combinations

Meter mains and meter combinations are similar. Meter mains incorporate space for a watt-hour meter (supplied by the utility company) and a main service disconnect within the same enclosure. Meter combinations incorporate space for a watt-hour meter and circuit breaker space for electrical distribution in a residence. These types of load centers are also used as trailer service panels. Meter combinations are primarily found on the West Coast but are also becoming popular in other areas of the country.

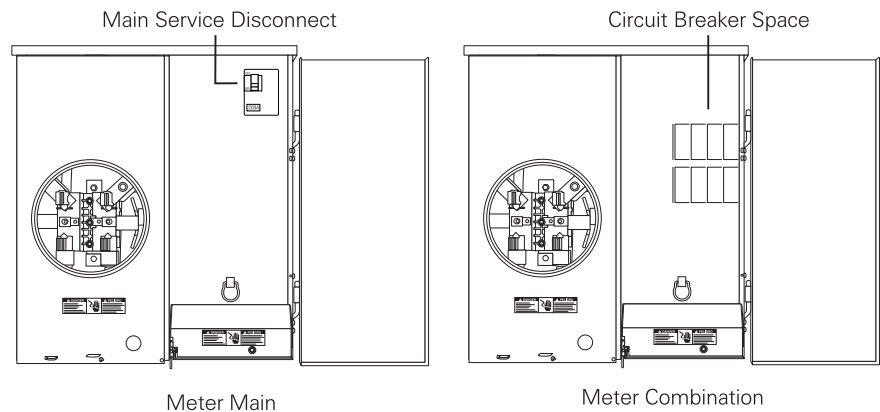

Modular Meter Centers Metering Systems

Modular meter centers are used for multi-family dwellings such as duplexes or apartment buildings. These are used in conjunction with Siemens load centers. Modular meter centers are available with two to six meter compartments.

Metering systems are another option for multi-family dwellings. These are self-contained systems with two to six meter compartments. Individual branch circuit breakers for tenants are located in a separate compartment adjacent to the meter socket.

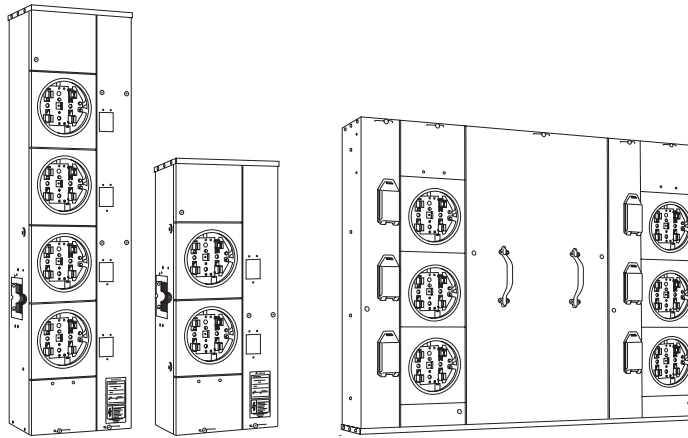

Modular Meter Centers

Metering System

Distribution

The incoming power then goes to a load center which provides circuit control and overcurrent protection. The power is distributed from the load center to various branch circuits for lighting, appliances, and electrical outlets.

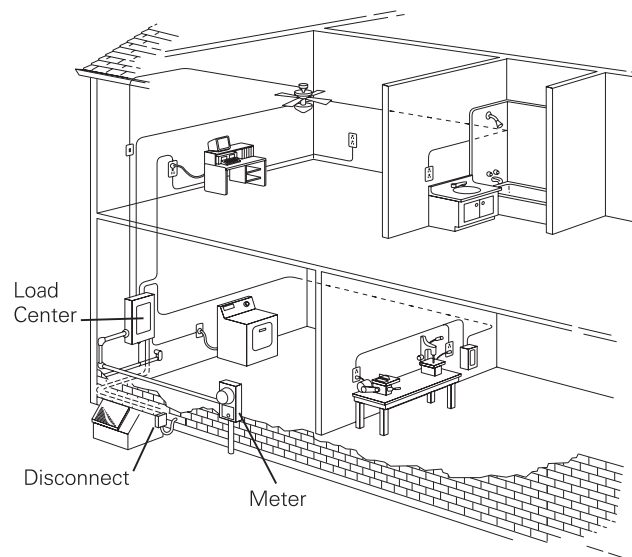

Load Centers

The term load center is an industry term used to identify a panelboard used in certain applications. Load centers are typically rated 225 amps or less and 240 volts maximum and are intended for use in residential applications. A typical load center consists of an enclosure, interior, and trim. Circuit breakers are mounted in the interior to provide circuit protection and control for light, heat, and power circuits.

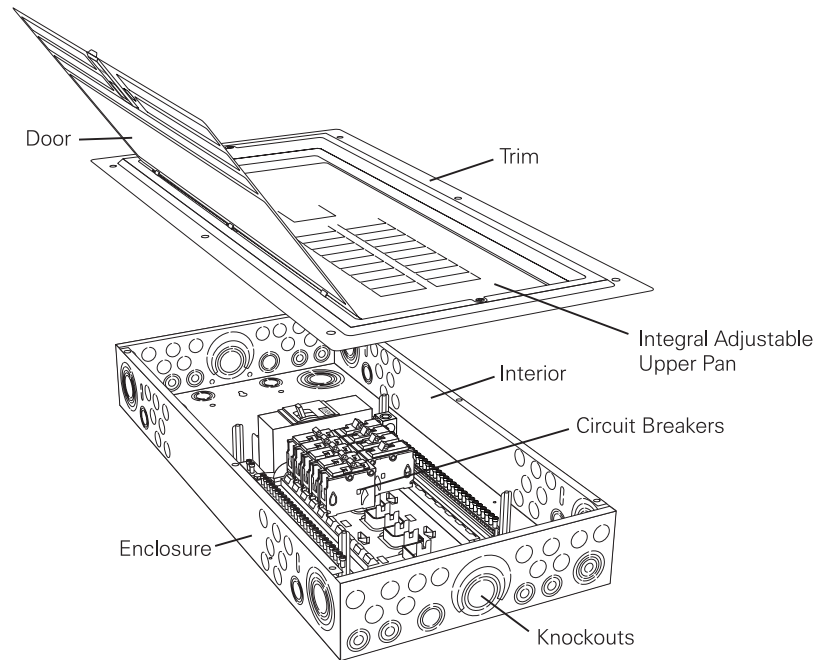

Circuit Breakers

Circuit breakers provide a manual means of energizing and de-energizing a circuit. In addition, circuit breakers provide automatic overcurrent protection of a circuit. Siemens residential circuit breakers are available with current ratings from 15-125 amps and a voltage rating of 120/240 volts. In residential applications, single-pole breakers protect 120 volt circuits; two-pole breakers protect 240 volt circuits.

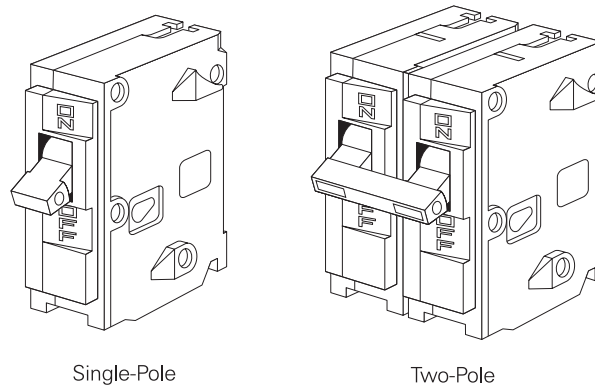

Circuit Breaker/ Surge Arrester

Siemens manufactures special types of circuit breakers for load center use. The Siemens circuit breaker/surge arrester mounts in a load center similarly to a conventional circuit breaker. This device protects electronic equipment, such as televisions or computers, from electrical surges on the system. Surges can come from electrical equipment, switching, or lightning.

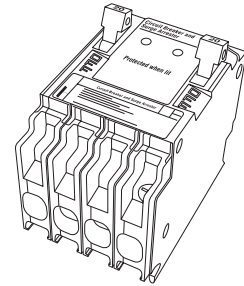
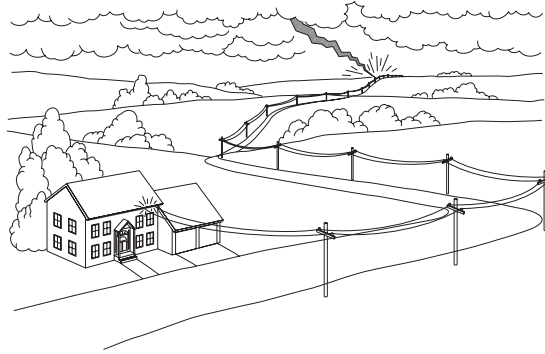

Surge Arrester

GFCI Circuit Breaker

The ground fault circuit interrupter (GFCI) is required on certain residential receptacles, such as bathroom receptacles, receptacles located within six feet of a kitchen sink, and outdoor receptacles. The GFCI is designed to interrupt a circuit when a ground fault occurs. Often the GFCI is mounted at the receptacle. When this is not feasible, a Siemens GFCI circuit breaker is installed in the load center.

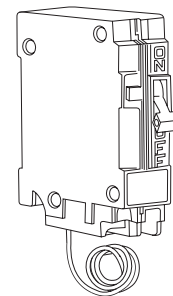

GFCI

AFCI Circuit Breaker

GFCI devices are designed to protect a person from getting a shock when touching an ungrounded appliance. Arc Fault Circuit Interrupters (AFCI), in comparison, protect against a fire being started from an unintended arc. An arc fault occurs when a current-carrying conductor has an arching condition to ground or another conductor. An AFCI device is intended to provide protection from the effects of arc faults by recognizing the characteristics unique to arcing and de-energizing the circuit when an arc fault is detected. The arc generated will cause the AFCI to trip. Arcs normally generated from electric equipment such as a light switch or power drill will not cause the AFCI to trip.

Arc-Fault Circuit Interrupter protection was first introduced in the 1999 *National Electrical Code*®. *NEC*® Article 210.12 and has an effective date of 2002. This requirement applies to all branch circuits that supply 125-volt, single-phase, 15- and 20-amp receptacle outlets installed in dwelling unit bedrooms.

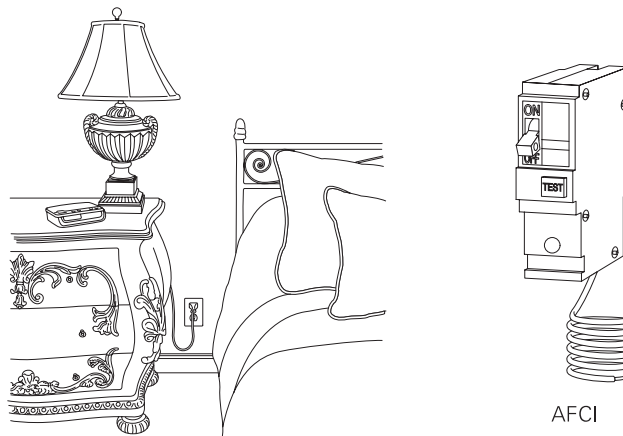

Enclosed Circuit Breakers and Disconnects

Siemens also manufactures circuit breaker enclosures and fused, non-fused, and molded case switch disconnects.

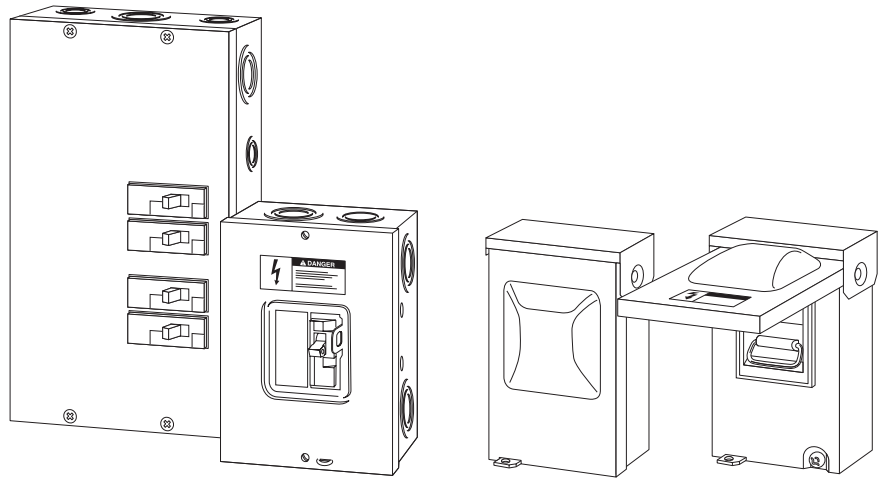

Enclosed Circuit Breaker

Enclosed Disconnect

Enclosed circuit breakers and disconnects provide a convenient means of disconnecting power to allow for the service of equipment such as an air conditioner located downstream from a service entrance load center.

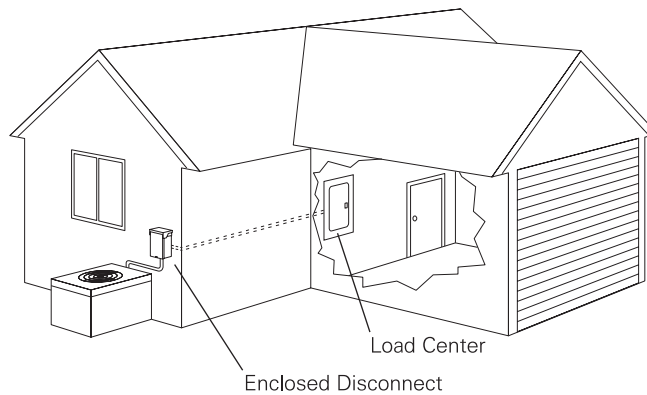

Load Center

Enclosed Disconnect

Review 1

1. A _____ is a device that converts mechanical energy into electrical energy.
2. A transformer that increases the voltage from primary to secondary is called a _____ transformer.
3. Phases are offset by _____ degrees in a three-phase system.
4. _____ volts is used for general-purpose receptacles and lighting in residential applications.
5. _____ is a type of electrical service that is run underground.
6. Modular meter centers can be supplied with two to _____ meter compartments.
7. The circuit breaker/ _____ _____ is a type of circuit breaker manufactured by Siemens that protects electronic equipment from electrical surges.
8. A _____ is required on certain residential receptacles such as bathroom receptacles and receptacles located within six feet of a kitchen sink.

Commercial Applications

Commercial applications range from small offices and stores to larger complexes such as hotels, restaurants, office buildings, and shopping malls. A small, single-tenant office building, for example, would not have a large demand for power. In this case, all that may be required is a single-position meter socket and panelboard. Small-demand, multiple-tenant applications, such as found in a small strip mall, might also have a low demand for electrical power. In these cases, metering systems or modular meter centers, as discussed in the “Residential Applications” section, might satisfy the load requirements.

Typically, commercial applications have higher demands for electrical power than residential applications. Electricity is used in commercial applications for heating, cooling, and lighting on a much larger scale. Some commercial applications may also operate machinery such as elevators and small conveyors.

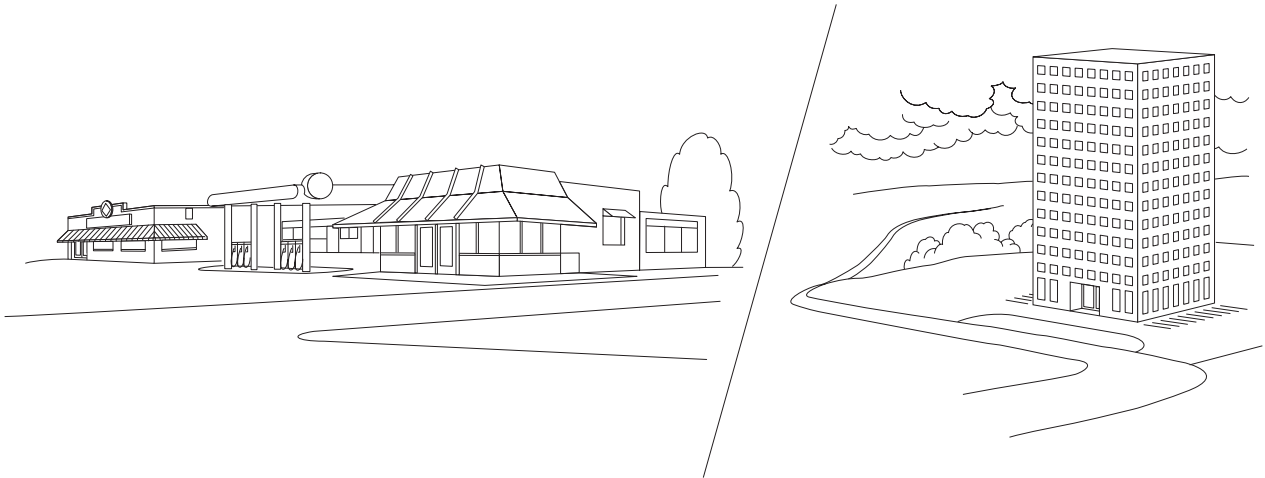

Busway

There are two methods to route power into a building or distribute power throughout a building. Electrical cable can be run inside conduit or busway can be used. The distribution system in a building frequently consists of a combination of busway and cable and conduit.

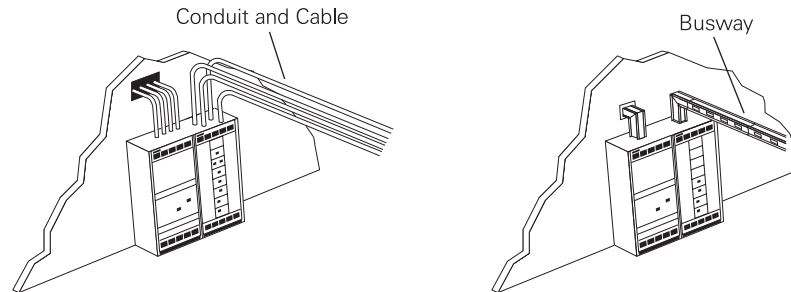

NEMA Definition

Busway, as defined by the National Electrical Manufacturers Association (NEMA), is a prefabricated electrical distribution system consisting of bus bars in a protective enclosure, including straight lengths, fittings, devices, and accessories.

Bus bars are the electrical conductors that carry power. The bars are individually insulated and enclosed in a housing. Siemens Sentron busway is illustrated below.

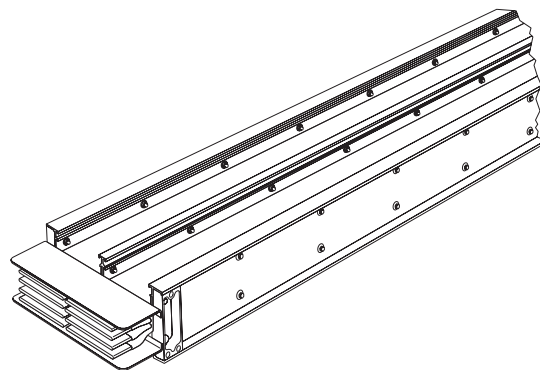

Service Entrance

Outdoor feeder busway is often used as service entrance conductors to bring power into a switchboard or panelboard. This may involve routing power from outside the building or from a transformer vault inside the building. For distribution inside the building indoor feeder or plug-in busway can be used.

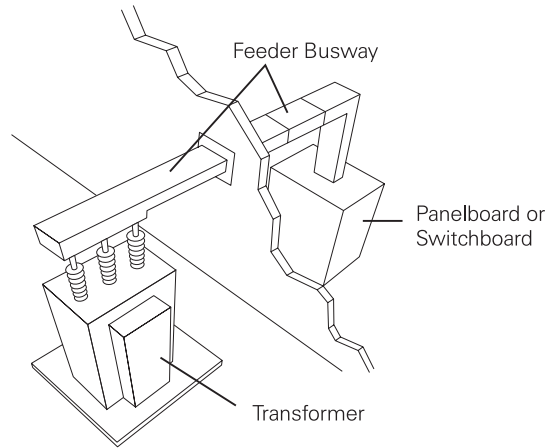

Busway Used in a Distribution System

A major advantage of busway is the ease in which busway sections are connected together. Electrical power can be supplied to any area of a building by connecting standard lengths of busway. It typically takes fewer man-hours to install or change a busway system than cable and conduit assemblies. Savings of 25 to 30% of the total installation cost are common when busway is used. Busway risers (vertical busway) can be installed economically in a high-rise building, such as the one illustrated below, where it can be used to distribute power to lighting and air-conditioning loads.

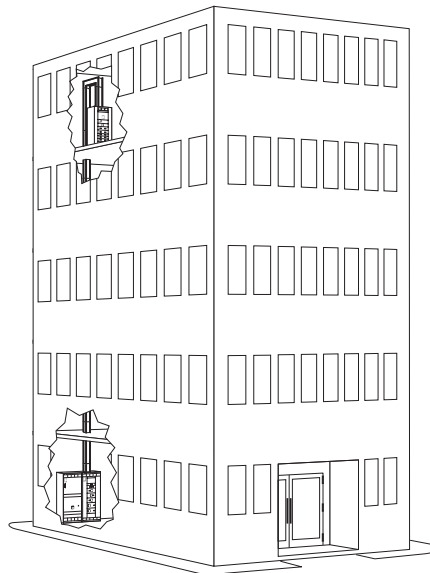

Power Distribution in Commercial Applications

Panelboards and switchboards can be used in commercial applications as service entrance equipment and for distribution of electrical power throughout the building. Although load centers, panelboards, and switchboards are similar in function and appearance, they are different products and designed to meet different needs. The following table shows how load centers, panelboards, and switchboards are defined. The *National Electrical Code*® (*NEC*®) makes no distinction between a load center and a panelboard.

Load Centers	Panelboards	Switchboards
Used to control light, heat, or power circuits.	Used to control light, heat, or power circuits.	Large single panel, frame, or assembly of panels.
Placed in a cabinet or cutout box.	Placed in a cabinet or cutout box.	Not intended to be installed in cabinets.
Mounted on or in a wall.	Mounted on or in a wall.	May be accessible from the rear as well as the front.
Accessible only from the front.	Accessible only from the front.	Switches, overcurrent and other protective devices, buses, and instruments mounted on the face or inside of switchboard.
Typically rated 225 amps or less and 240 volts max.	Siemens panelboards are available with max ratings from 125 to 1200 amps, voltage ranges from 120 to 600 volts.	Siemens switchboards are available with max ratings up to 6000 amps at 600 volts.
Industry term used to identify a panelboard used in certain residential and light commercial applications.		

Panelboard Construction

Panelboards are constructed in a similar manner as load centers. Panelboards are more robust and able to handle the more demanding loads of commercial applications.

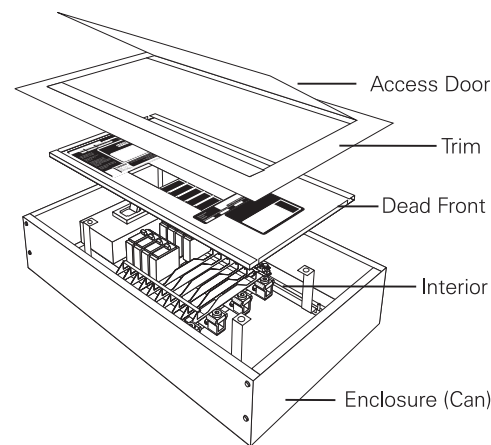

NEC® and *National Electrical Code*® are registered trademarks of the National Fire Protection Association.

Panelboards

Siemens manufactures a variety of panelboards to meet various distribution requirements. P1, SE, and S3 lighting and power panelboards are smaller in size and well suited to demands of commercial applications. P1 panelboards handle loads up to 400 amps. SE and S3 panelboards handle loads up to 600 amps. S4, S5, F1, and F2 power panelboards are designed for power applications up to 1200 amps.

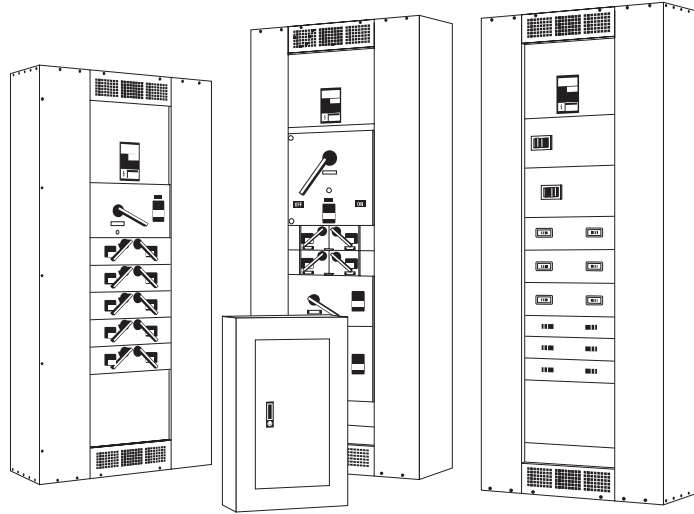

Switchboard Construction

Switchboards typically consist of a service section and one or more distribution sections. The service section can be fed directly from the utility transformer. In addition to the main disconnect, the service section usually contains utility or customer metering provisions.

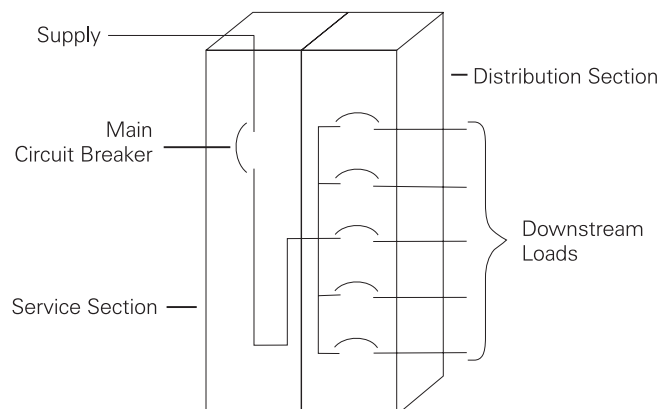

SB1, SB2, SB3

Siemens manufactures a variety of switchboards. The type of switchboard selected is determined by a variety of factors such as space, load, and environment. Sentron SB1, SB2, and SB3 are selected when space is a consideration. These switchboards are accessed from the front and most can be mounted against a wall. SB1, SB2, and SB3 switchboards can be found in a variety of commercial, institutional, and industrial buildings.

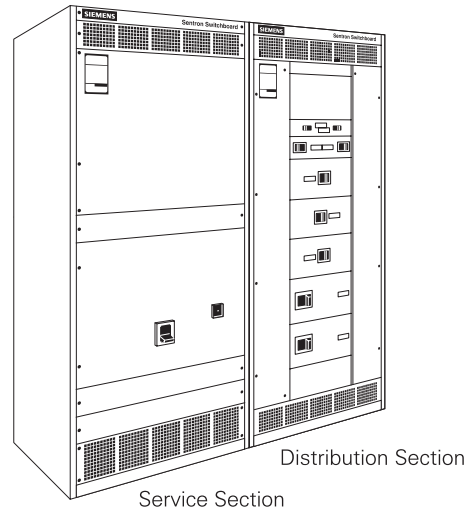

RCIII Switchboards

RCIII switchboards are rear connected and require rear access and are typically found in industrial applications.

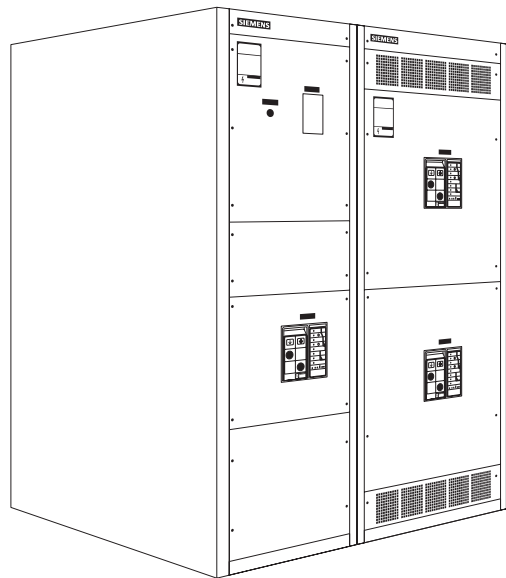

Super Blue Pennant

The Super Blue Pennant™ switchboard is designed as a service entrance switchboard. The main service disconnect and distribution devices are contained in a single unit. Super Blue Pennant switchboards are rated for 400, 600, or 800 amps.

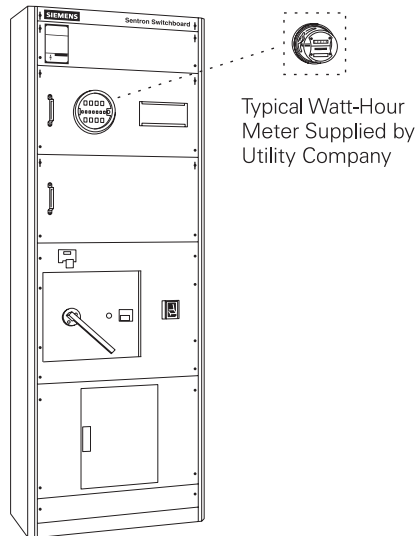

Commercial Metering

Commercial metering switchboards are designed for Switchboards applications where multi-metering is required. These applications include shopping centers, office buildings, and other commercial buildings with multiple tenants. Type SMM switchboards are designed to meet west-coast utility specifications. Type MMS switchboards are similar to the SMM switchboards, but utilize a ringless type meter, manual bypass, and no test blocks. The switchboard main service is rated up to 4000 amps at 480 volts, and service mains are rated up to 2000 amps for both types of switchboards. Commercial metering switchboards can be supplied with 2, 3, 4, or 6 sockets.

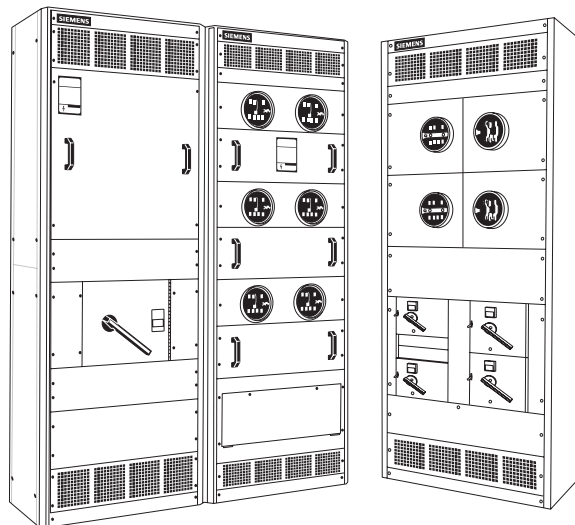

Type SMM Switchboard

Type MMS Switchboard

Panelboard Example

When choosing between a panelboard and a switchboard in commercial applications, it is not always clear which product you should choose. There are a number of factors to consider such as total load, routing of the electrical power throughout a building, and future expansion. For example, in a small commercial application 480 volts supplied by the utility is applied to the input of a panelboard. Various outputs are used to supply power throughout the facility. One output might be used to supply power to a second panelboard through a transformer which is used for lighting and electrical outlets. Another output might be used to supply power to a motor through a motor starter.

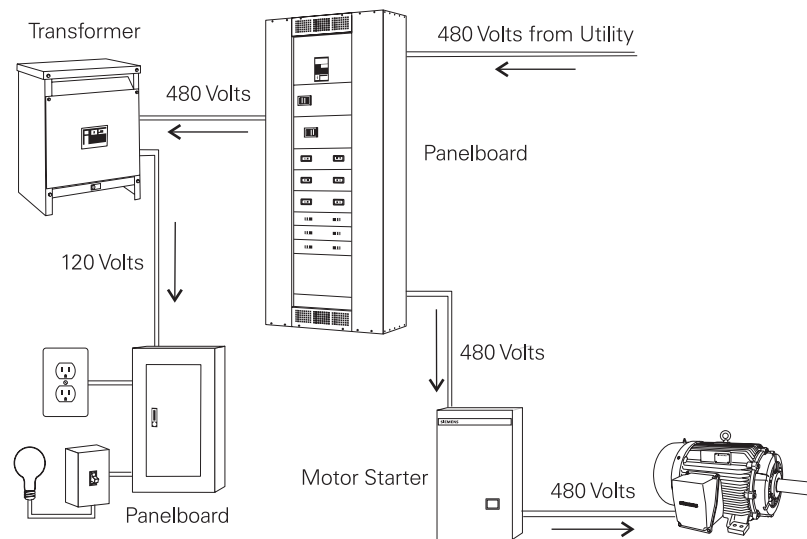

Switchboard Example

In larger or more demanding commercial applications, switchboards can also be used to distribute power. For example, 480 volts supplied by the utility is applied to the input of a switchboard. One output might be used to supply power to a small panelboard through a transformer which is used for lighting and electrical outlets. Another output might be used to supply power to a larger panelboard located further away or on another floor. This panelboard supplies power to another panelboard for lighting and receptacles in that area. In addition, the panelboard supplies power to control a motor.

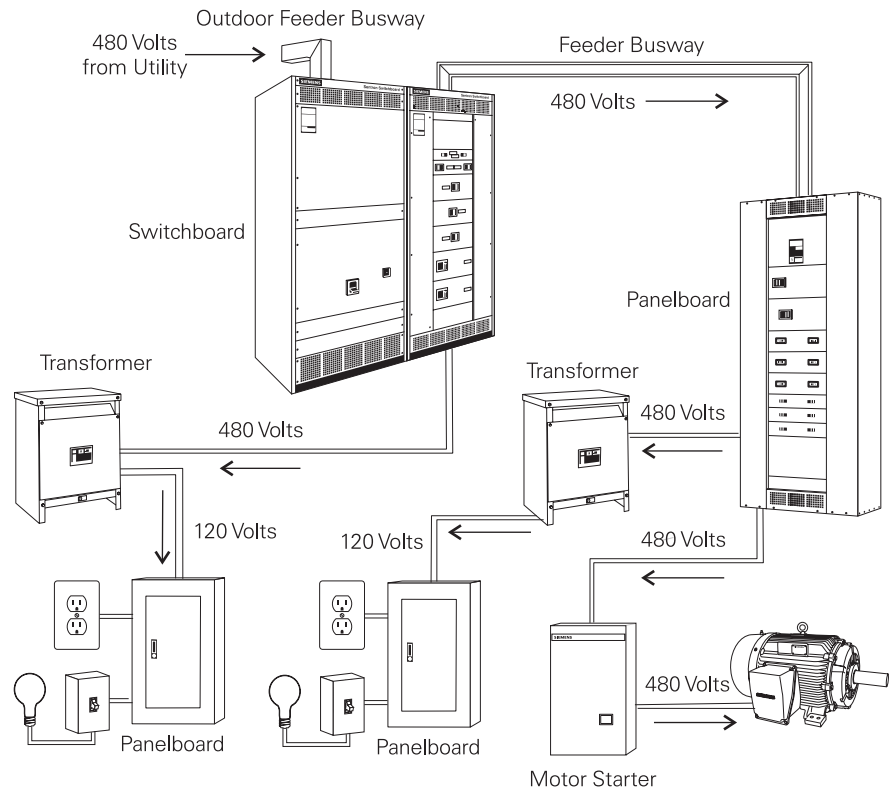

Commercial Applications

Commercial applications range from small offices and stores to larger complexes such as hotels, restaurants, office buildings, and shopping malls. A small, single-tenant office building, for example, would not have a large demand for power. In this case, all that may be required is a single-position meter socket and panelboard. Small-demand, multiple-tenant applications, such as found in a small strip mall, might also have a low demand for electrical power. In these cases, metering systems or modular meter centers, as discussed in the “Residential Applications” section, might satisfy the load requirements.

Typically, commercial applications have higher demands for electrical power than residential applications. Electricity is used in commercial applications for heating, cooling, and lighting on a much larger scale. Some commercial applications may also operate machinery such as elevators and small conveyors.



Busway

There are two methods to route power into a building or distribute power throughout a building. Electrical cable can be run inside conduit or busway can be used. The distribution system in a building frequently consists of a combination of busway and cable and conduit.

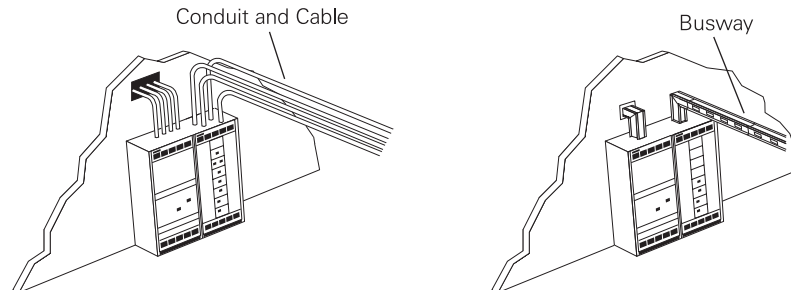

NEMA Definition

Busway, as defined by the National Electrical Manufacturers Association (NEMA), is a prefabricated electrical distribution system consisting of bus bars in a protective enclosure, including straight lengths, fittings, devices, and accessories.

Bus bars are the electrical conductors that carry power. The bars are individually insulated and enclosed in a housing. Siemens Sentron busway is illustrated below.

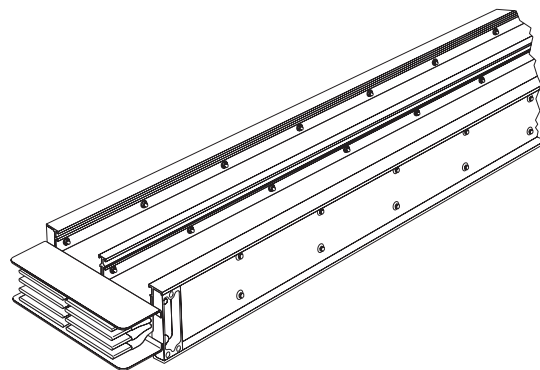

Service Entrance

Outdoor feeder busway is often used as service entrance conductors to bring power into a switchboard or panelboard. This may involve routing power from outside the building or from a transformer vault inside the building. For distribution inside the building indoor feeder or plug-in busway can be used.

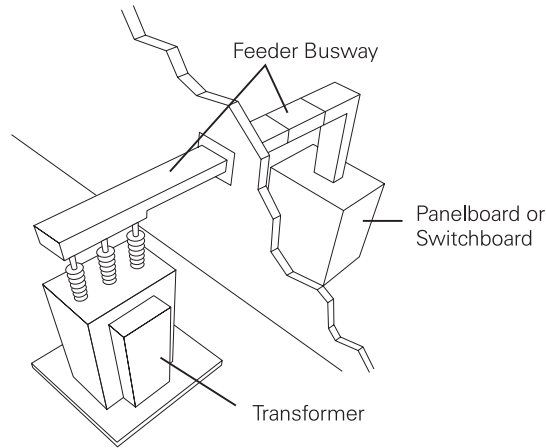

Busway Used in a Distribution System

A major advantage of busway is the ease in which busway sections are connected together. Electrical power can be supplied to any area of a building by connecting standard lengths of busway. It typically takes fewer man-hours to install or change a busway system than cable and conduit assemblies. Savings of 25 to 30% of the total installation cost are common when busway is used. Busway risers (vertical busway) can be installed economically in a high-rise building, such as the one illustrated below, where it can be used to distribute power to lighting and air-conditioning loads.

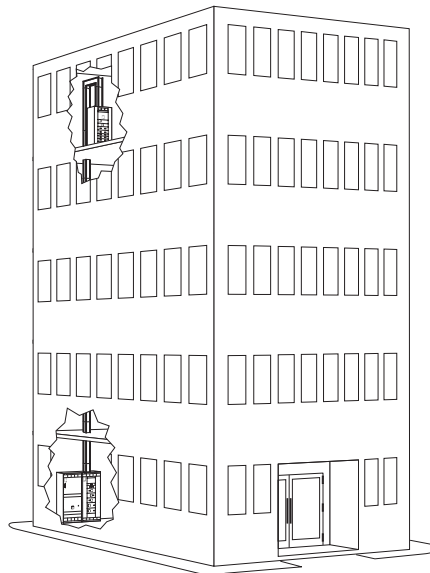

Power Distribution in Commercial Applications

Panelboards and switchboards can be used in commercial applications as service entrance equipment and for distribution of electrical power throughout the building. Although load centers, panelboards, and switchboards are similar in function and appearance, they are different products and designed to meet different needs. The following table shows how load centers, panelboards, and switchboards are defined. The *National Electrical Code*® (*NEC*®) makes no distinction between a load center and a panelboard.

Load Centers	Panelboards	Switchboards
Used to control light, heat, or power circuits.	Used to control light, heat, or power circuits.	Large single panel, frame, or assembly of panels.
Placed in a cabinet or cutout box.	Placed in a cabinet or cutout box.	Not intended to be installed in cabinets.
Mounted on or in a wall.	Mounted on or in a wall.	May be accessible from the rear as well as the front.
Accessible only from the front.	Accessible only from the front.	Switches, overcurrent and other protective devices, buses, and instruments mounted on the face or inside of switchboard.
Typically rated 225 amps or less and 240 volts max.	Siemens panelboards are available with max ratings from 125 to 1200 amps, voltage ranges from 120 to 600 volts.	Siemens switchboards are available with max ratings up to 6000 amps at 600 volts.
Industry term used to identify a panelboard used in certain residential and light commercial applications.		

Panelboard Construction

Panelboards are constructed in a similar manner as load centers. Panelboards are more robust and able to handle the more demanding loads of commercial applications.

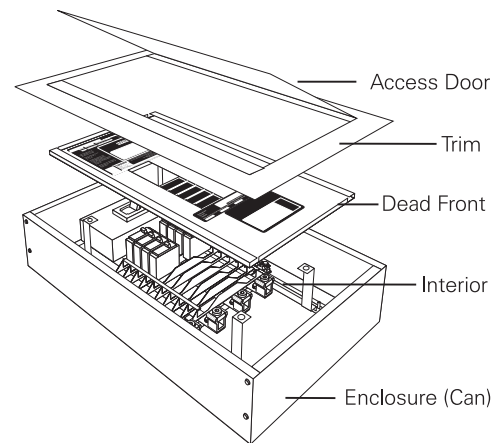

NEC® and *National Electrical Code*® are registered trademarks of the National Fire Protection Association.

Panelboards

Siemens manufactures a variety of panelboards to meet various distribution requirements. P1, SE, and S3 lighting and power panelboards are smaller in size and well suited to demands of commercial applications. P1 panelboards handle loads up to 400 amps. SE and S3 panelboards handle loads up to 600 amps. S4, S5, F1, and F2 power panelboards are designed for power applications up to 1200 amps.

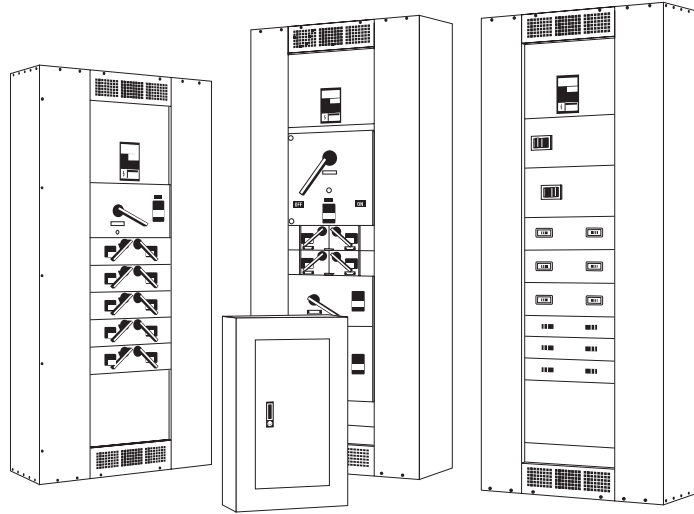

Switchboard Construction

Switchboards typically consist of a service section and one or more distribution sections. The service section can be fed directly from the utility transformer. In addition to the main disconnect, the service section usually contains utility or customer metering provisions.

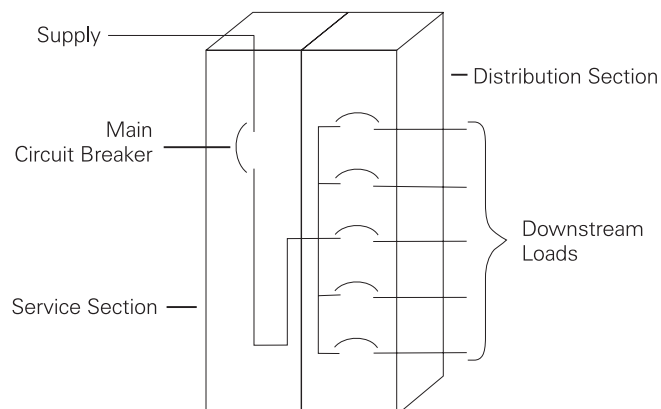

SB1, SB2, SB3

Siemens manufactures a variety of switchboards. The type of switchboard selected is determined by a variety of factors such as space, load, and environment. Sentron SB1, SB2, and SB3 are selected when space is a consideration. These switchboards are accessed from the front and most can be mounted against a wall. SB1, SB2, and SB3 switchboards can be found in a variety of commercial, institutional, and industrial buildings.

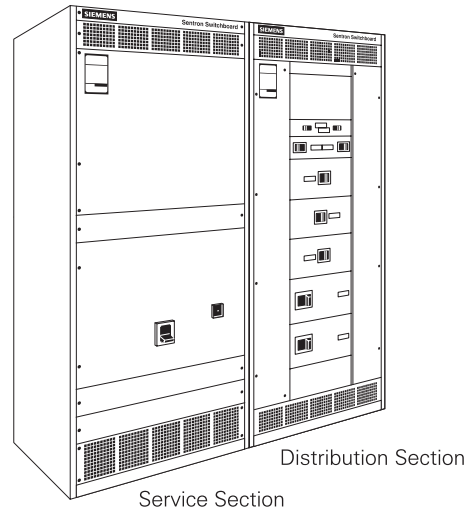

RCIII Switchboards

RCIII switchboards are rear connected and require rear access and are typically found in industrial applications.

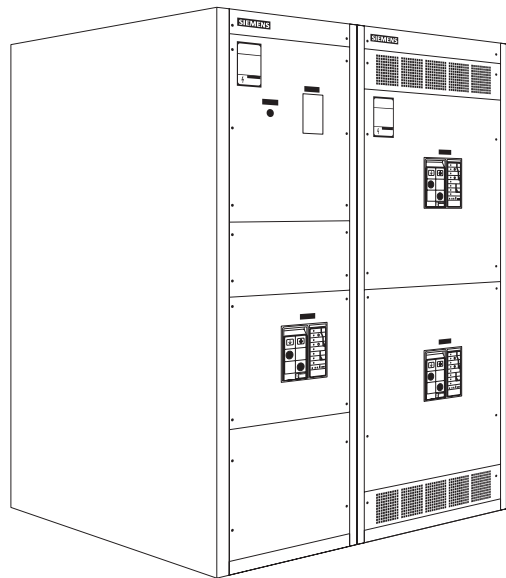

Super Blue Pennant

The Super Blue Pennant™ switchboard is designed as a service entrance switchboard. The main service disconnect and distribution devices are contained in a single unit. Super Blue Pennant switchboards are rated for 400, 600, or 800 amps.

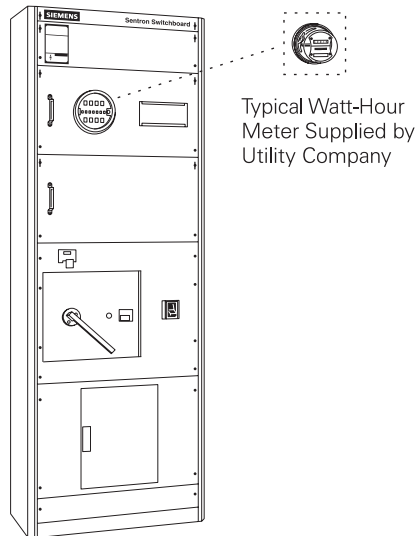

Commercial Metering

Commercial metering switchboards are designed for Switchboards applications where multi-metering is required. These applications include shopping centers, office buildings, and other commercial buildings with multiple tenants. Type SMM switchboards are designed to meet west-coast utility specifications. Type MMS switchboards are similar to the SMM switchboards, but utilize a ringless type meter, manual bypass, and no test blocks. The switchboard main service is rated up to 4000 amps at 480 volts, and service mains are rated up to 2000 amps for both types of switchboards. Commercial metering switchboards can be supplied with 2, 3, 4, or 6 sockets.

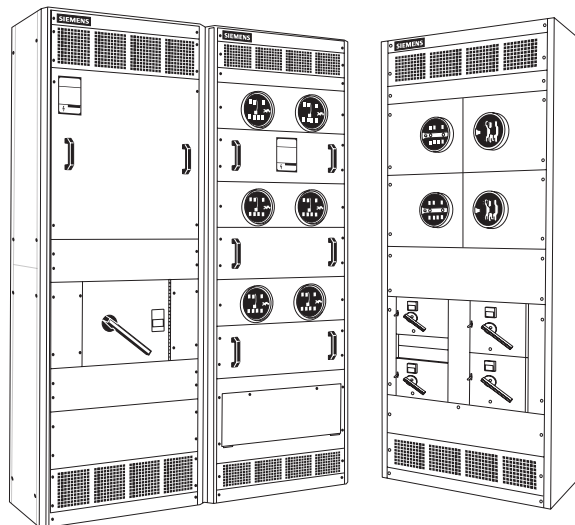

Type SMM Switchboard

Type MMS Switchboard

Panelboard Example

When choosing between a panelboard and a switchboard in commercial applications, it is not always clear which product you should choose. There are a number of factors to consider such as total load, routing of the electrical power throughout a building, and future expansion. For example, in a small commercial application 480 volts supplied by the utility is applied to the input of a panelboard. Various outputs are used to supply power throughout the facility. One output might be used to supply power to a second panelboard through a transformer which is used for lighting and electrical outlets. Another output might be used to supply power to a motor through a motor starter.

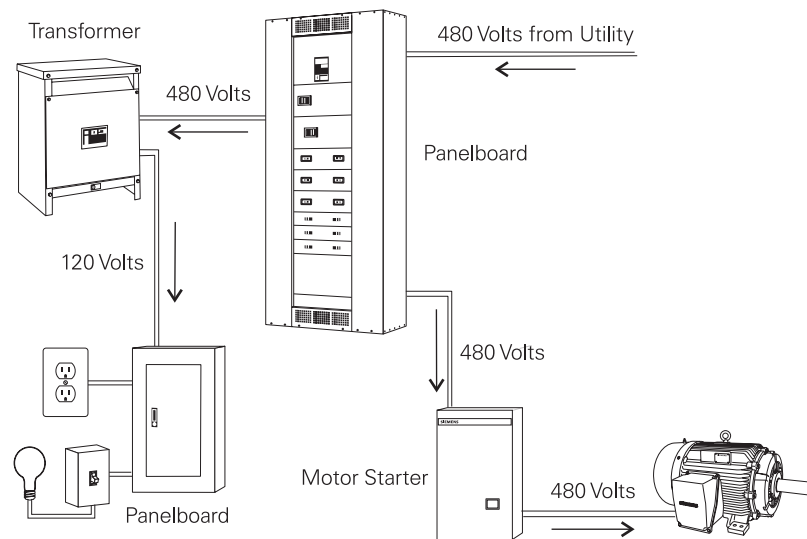

Switchboard Example

In larger or more demanding commercial applications, switchboards can also be used to distribute power. For example, 480 volts supplied by the utility is applied to the input of a switchboard. One output might be used to supply power to a small panelboard through a transformer which is used for lighting and electrical outlets. Another output might be used to supply power to a larger panelboard located further away or on another floor. This panelboard supplies power to another panelboard for lighting and receptacles in that area. In addition, the panelboard supplies power to control a motor.

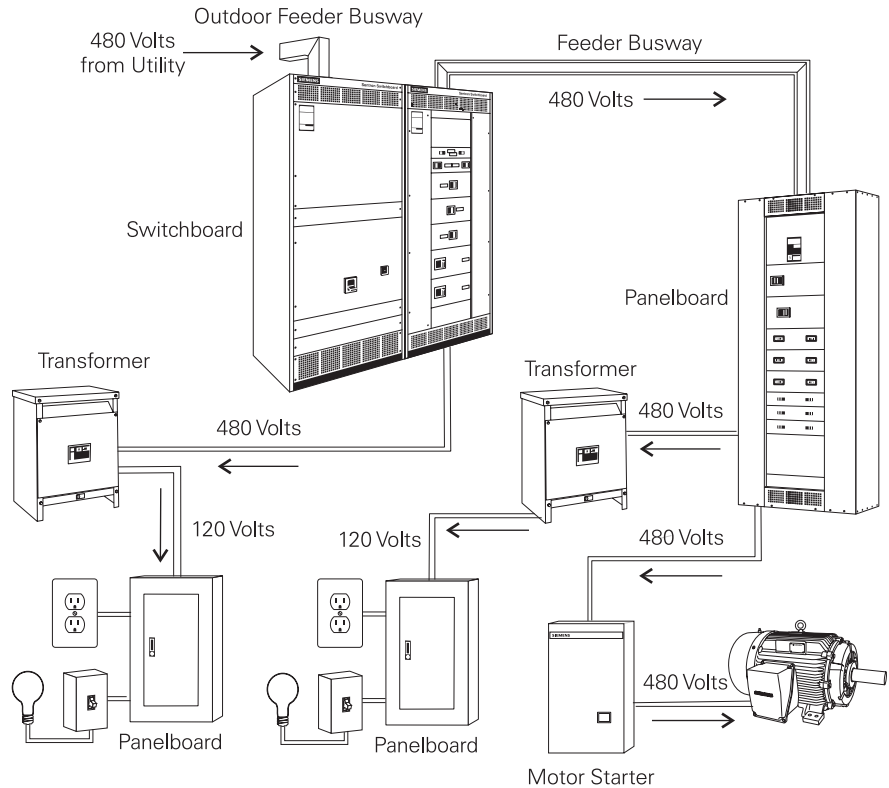

Circuit Breakers

Circuit breakers are used in panelboards and switchboards to provide circuit protection and provide a means of energizing and de-energizing a circuit. Siemens Sentron molded case circuit breakers (MCCB) used in panelboards are available with current ratings from 15 to 1200 amps.

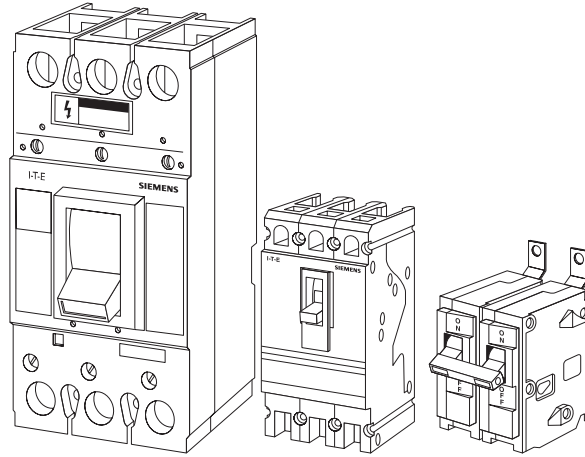

Sentron series molded case circuit breakers used in switchboards are available up to 2000 amps. Siemens encased systems breakers are generically called insulated case circuit breakers (ICCB). Siemens insulated case circuit breakers are available with current ratings up to 5000 amps.

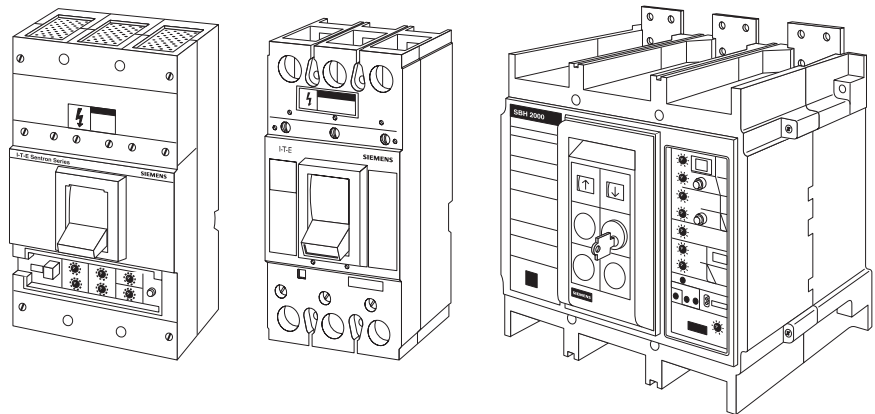

Sentron Series
Sensitrip III MCCB

Sentron Series MCCB

Insulated Case Circuit Breaker (ICCB)

Fusible Disconnect Switch

A fusible disconnect switch is another type of device used in panelboards and switchboards to provide overcurrent protection. Properly sized fuses located in the switch open when an overcurrent condition exists. Siemens fusible switches are available with ampere ratings from 30 to 1200 amps.

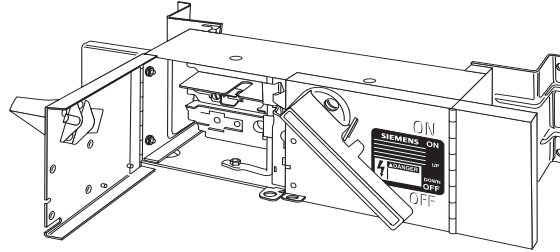

Bolted Pressure Switches

Bolted pressure switches are also used in switchboards as main disconnects. Bolted pressure switches are available in ratings up to 4000 amps.

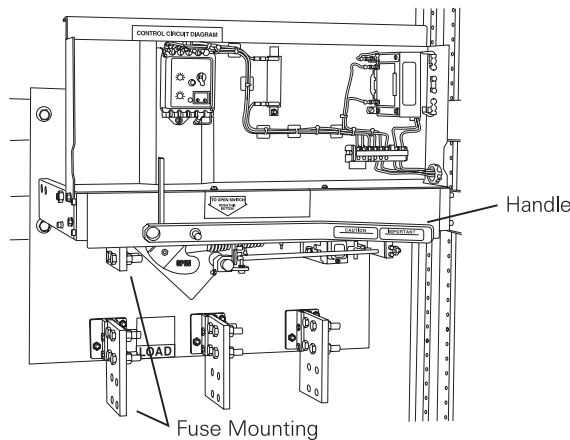

Type RL Circuit Breaker

Siemens RL series low voltage power circuit breakers can also be used in Siemens switchboards. RL series circuit breakers are designed with current carrying capacities up to 5000 amps.

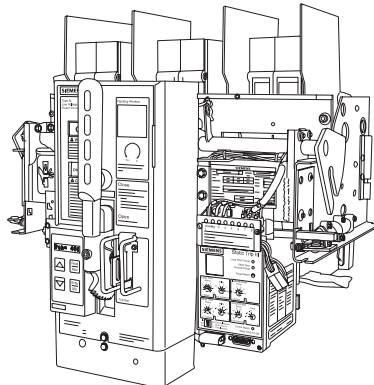

Meters

Siemens offers a full line of power meters for use in the service section of switchboards. Meters can be used to measure real-time RMS (root-mean-square) values of phase currents, phase and line voltages, power usage, power factor, and peak demand. In addition, Siemens also has meters capable of monitoring power quality, such as K-factor, crest factor, individual harmonics, and total harmonics. Meters such as the 9350 and 9600 can act as a Web server. When combined with an Ethernet port, these meters offer quick and easy access to monitored values without the need for special software.

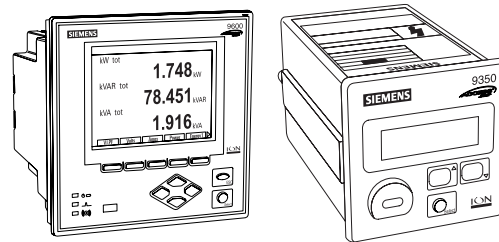

9600

9350

ACCESS™

Siemens meters have communication capability using the Siemens ACCESS system software. Siemens ACCESS is more than just power meters and other hardware. The ACCESS power management and control system is a networked system comprised of a variety of devices that monitor and control an electrical distribution system. The ACCESS system provides electrical data necessary for troubleshooting, power quality studies, preventative maintenance, and cost allocation. A power monitoring and management system, such as Siemens ACCESS, can identify potential problems before they cause costly breakdowns.

Here are just five benefits to using the ACCESS system.

- Reduce or eliminate unplanned outages
- Proactively manage power systems to minimize utility bills
- Automate allocation of utility power bills
- Optimize existing capital equipment used in power systems
- Record and analyze power quality and power system anomalies



TPS

Computers and other office equipment are susceptible to the high energy levels caused by an electrical surge, whether it is caused by electrical equipment or lightning. Any component between the source of the surge and ground can be damaged. One option available to protect equipment from electrical surges is the Siemens TPS (transient protection system). The TPS clamps voltage spikes before they damage expensive and sensitive equipment. Siemens TPS can be used with busway, panelboards, and switchboards.

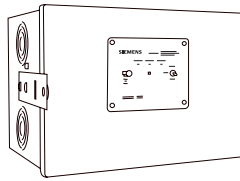

Busway TPS

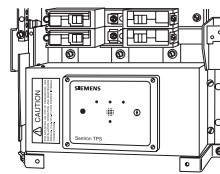

TPS Mounted in
S1 Panelboard

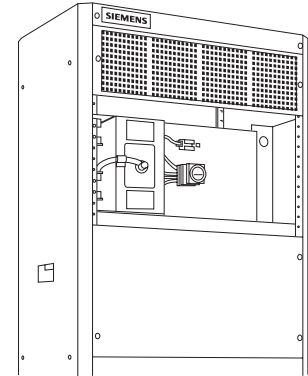

TPS Mounted in
SB3 Switchboard

AC Motors

AC motors, such as the Siemens Medallion™ motors, can be found in a variety of applications in commercial buildings. Siemens Medallion EPACT efficiency motors are high performance motors designed to meet the requirements of the U.S. Energy Policy Act of 1992 (EPA Act). EPACT efficiency motors are available from 1 to 200 HP.

Siemens Medallion PE-21 Plus motors are premium efficiency motors available from 1 to 500 HP. Premium efficiency motors typically cost slightly more than standard efficiency motors, but payback is in energy savings.

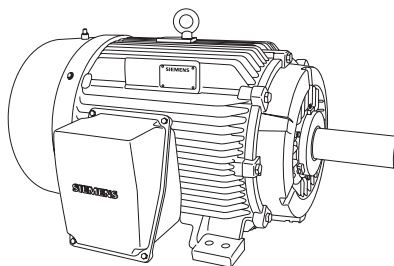

Motors can be found on fans, pumps, elevators, escalators, and conveyors. A small conveyor, for example, might be used in a department store to move packages from a storeroom to a customer pickup location.

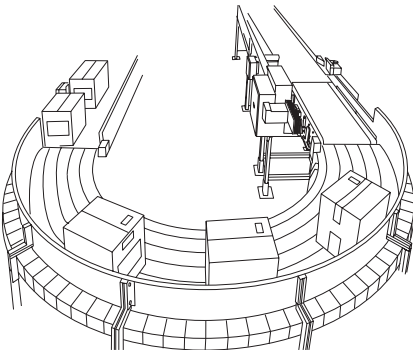

Safety Switches

Safety switches provide a means for a service entrance or a disconnecting means and fault protection for motors. A safety switch is simply a switch located in its own enclosure. The enclosure provides a degree of protection to personnel against incidental contact with live electrical equipment. Safety switches are available with or without provisions for fuses. Siemens enclosed switches are available with current ratings from 30 amps to 4000 amps.

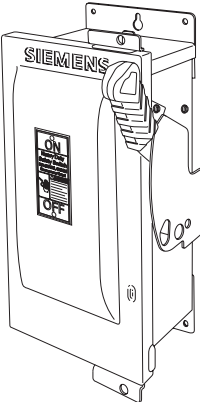

Heavy Duty



General Duty

Motor Starter

Although safety switches can be used to start and stop motors, many motor applications require the use of remote control devices to start and stop the motor. Motor starters are commonly used to provide this function. Some motor starters have multi-speed and reversing capability.

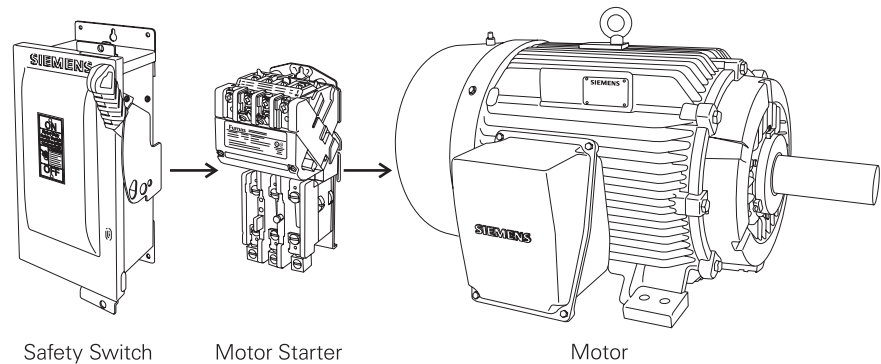

A motor starter consists of a magnetic contactor and an overload relay. The contactor is an electromagnetic device used to close and open a set of contacts, which starts and stops the connected motor. If an overload occurs, excessive heat can build up in a motor which can damage the motor's winding insulation. The overload relay will automatically stop the motor in this event.

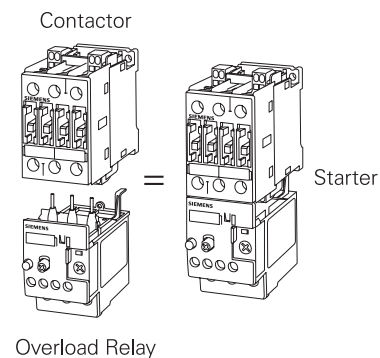

Siemens manufactures a variety of starters, such as the Furnas INNOVA PLUS and the Furnas ESP100.

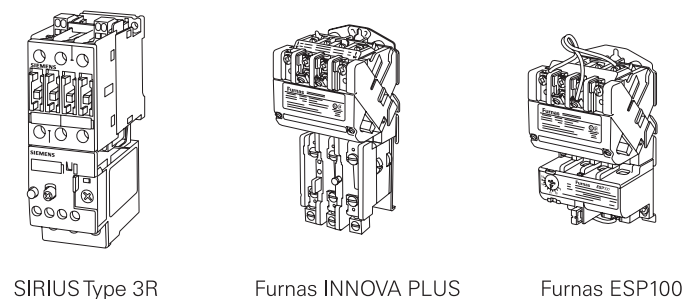

Review 2

1. _____ may be accessible from the rear as well as the front?
 - a. Load Centers
 - b. Panelboards
 - c. Switchboards
 - d. All the Above
2. _____ is a system manufactured by Siemens to provide protection in panelboards, switchboards, and busway from electrical surges.
3. Switchboards typically consist of a service section and one or more _____ sections.
4. The _____ commercial metering switchboards are designed to meet west coast utility specifications.
5. Siemens safety switches are available with current ratings from 30 to _____ amps.

Industrial Applications

Voltage Classes

Electrical power requirement is a major consideration in industrial applications. Typically voltage is received and distributed at much higher levels than residential and commercial applications. Equipment must be specially designed to receive high transmission voltage from a utility company, and effectively distribute it throughout the industrial facility. Industrial facilities typically make large demands on the electrical utility, making it impractical to supply voltage at lower levels. The level of voltage supplied by the utility company varies with the requirements of the facility. For discussion purposes, it is sometimes convenient to divide voltages into classes. The Institute of Electrical and Electronics Engineers (IEEE), for example, divides voltage systems into the following classes:

Low-Voltage Systems	Medium-Voltage Systems	High-Voltage Systems	Extra-High-Voltage (EHV) Systems
1000 volts or Less	Greater than 1000 volts to 100,000 volts*	Greater than 100,000 volts to 230,000 volts	Greater than 240,000 volts to 800,000 volts

*Most medium-voltage systems are rated at 38,000 volts or less.

Since the voltages supplied to the industrial facilities are typically either low or medium voltages, this discussion will focus on low and medium voltage systems beginning with a discussion of switchgear.

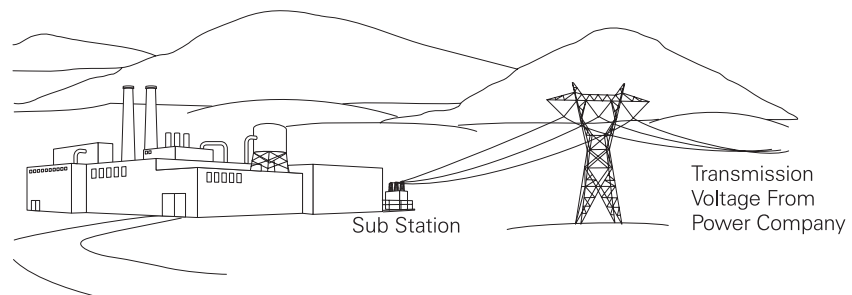

Switchgear

The term switchgear is used to describe coordinated devices used for control and protection of equipment such as generators, transformers, capacitor banks, motors, and distribution lines. Switchgear is accessible from the front and rear. Siemens manufactures switchgear for low- and medium-voltage applications.

Medium-Voltage Switchgear

Medium-voltage switchgear normally conforms to design requirements for metal-clad switchgear. Siemens manufactures medium-voltage switchgear rated at various levels to meet the requirements of typical medium-voltage applications found in many industrial facilities.

38 kV Switchgear

Siemens 38 kV medium-voltage, metal-clad switchgear is rated for voltages between 16.5 kV (16,000 volts) and 38 kV (38,000 volts). Siemens metal-clad switchgear features 38-3AF circuit breakers which are available in 1200, 2000, and 3000 amp current ratings.

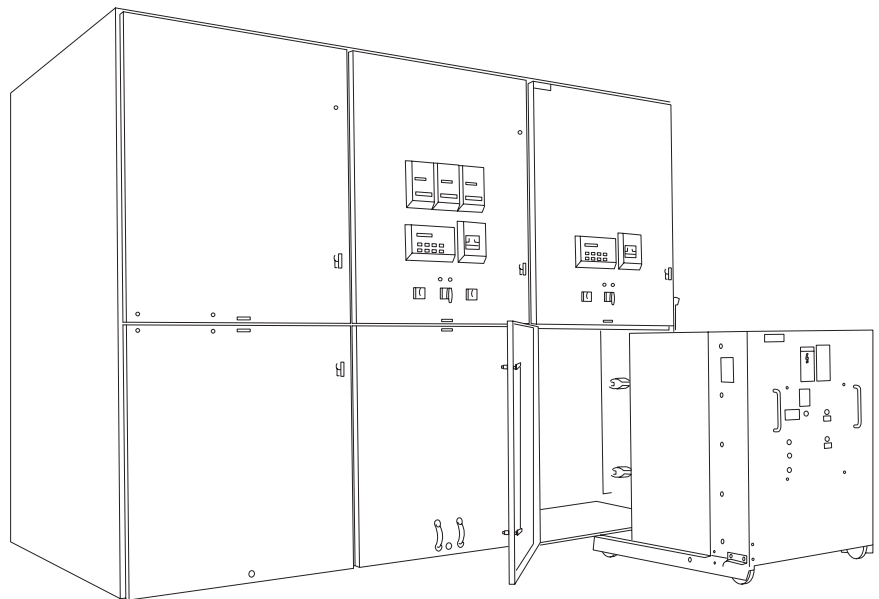

5 - 15 kV Switchgear

Siemens 5 - 15 kV metal-clad switchgear is designed to handle voltages of 4.16 kV (4160 volts), 7.2 kV (7200 volts), and 13.8 kV (13,800 volts). Siemens 5 - 15 kV switchgear features vacuum circuit breakers rated for 1200, 2000, and 3000 amps.

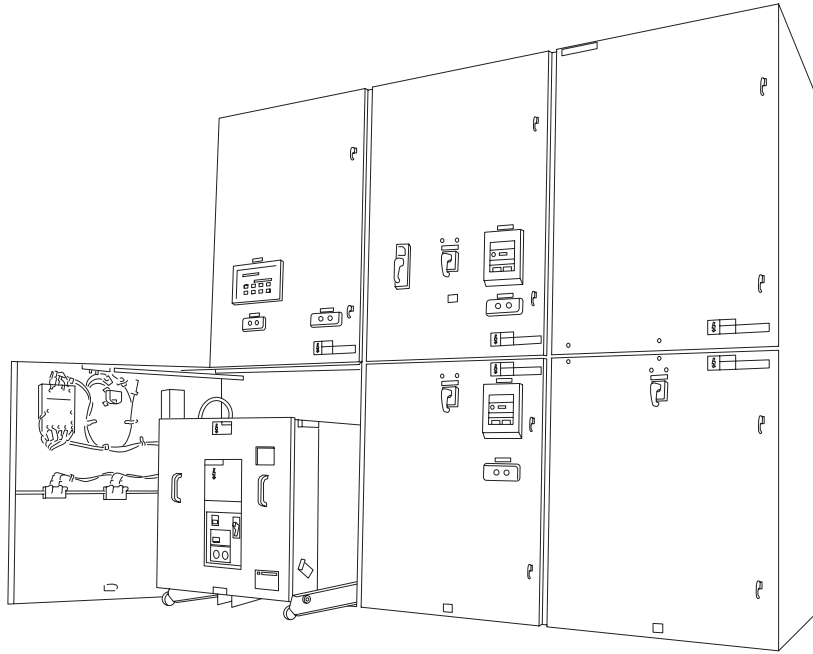

NXAIR P

NXAIR P medium voltage switchgear is "arc vented." This design handles arc fault events more safely by directing expanding gases of an arc fault up and away from the operator. NXAIR P meets American standards (ANSI) and international standards (IEC) for global compliance. NXAIR P handles voltages from 5 kV to 15 kV with vacuum type circuit breakers rated from 1200 amps to 4000 amps.

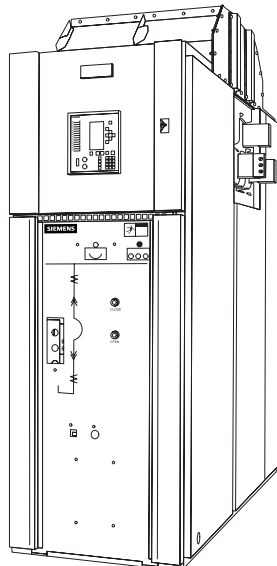

Medium-Voltage Switchgear Example

A large industrial facility, such as a paper or steel mill, receives electrical power at a substation from the utility company at high transmission voltage levels. The voltage is stepped down to a medium-voltage level at the substation for distribution by the industrial facility. Large industrial facilities can be spread out over several acres and incorporate many large buildings. Exact power distribution will depend on machinery location and power requirements. Multiple medium-voltage, metal-clad switchgear units could be used if the facility and the power demand were large enough.

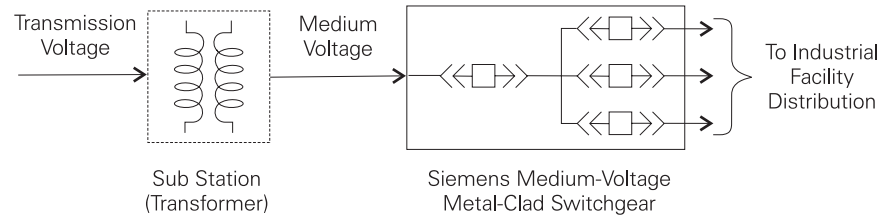

It can be seen in this example that one 38 kV metal-clad switchgear unit is supplying power to two 5 kV metal-clad switchgear units and one 15 kV metal-clad switchgear unit. This is one way power might be distributed throughout a large industrial complex made up of several buildings, each requiring great amounts of electrical power.

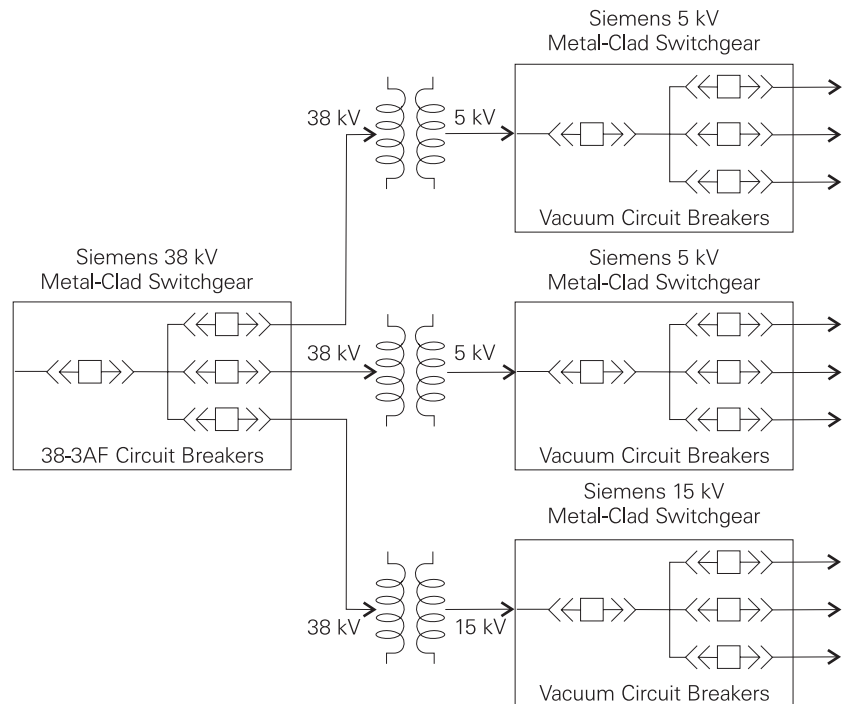

Low-Voltage Switchgear

Low-voltage switchgear normally conforms to the design requirements for metal-enclosed switchgear. Siemens low-voltage switchgear can be used on distribution systems with 208, 240, 480, or 600 volts with currents up to 5000 amps in the Type R (indoor) and 4000 amps in the Type SR (outdoor). TPS (transient protection system) is available for Type R, low voltage switchgear applications.

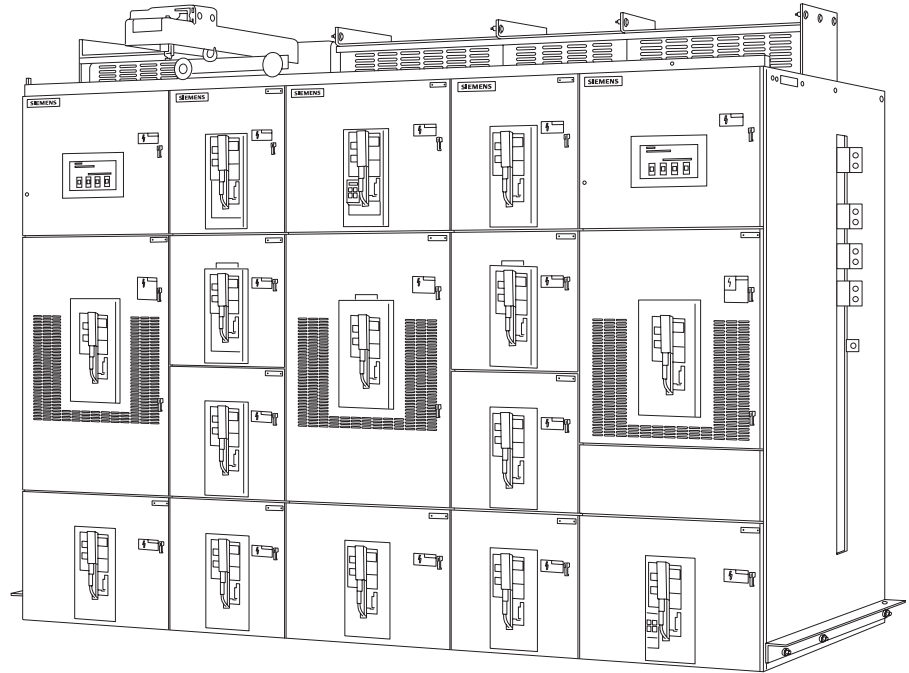

Type RL Circuit Breaker

Siemens RL series low voltage power circuit breakers are used in the Siemens low voltage switchgear. RL series circuit breakers are designed for up to 600-volt service with current carrying capacities up to 5000 amps.

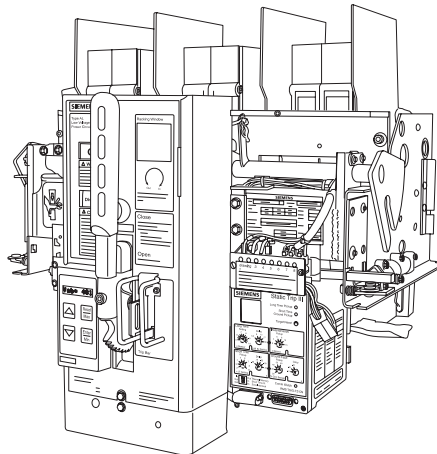

Secondary Unit Substation

Another method used to handle distribution voltage is with a secondary unit substation.

A typical secondary unit substation consists of three sections which are coordinated in design to form one uniform enclosure.

1. An incoming section that accepts incoming voltage and may include a primary switch.
2. A transformer section that transforms incoming voltage down to a utilization voltage.
3. An outgoing section that distributes power to outgoing feeders and provides protection for these feeders.

A primary switch is used to provide a means to connect and disconnect the secondary unit substation from the supply service. The transformer section can be liquid filled, ventilated dry type, or a cast-coil type. The outgoing section can be a Siemens Sentron switchboard, such as the RCIII, or Type R low-voltage switchgear.

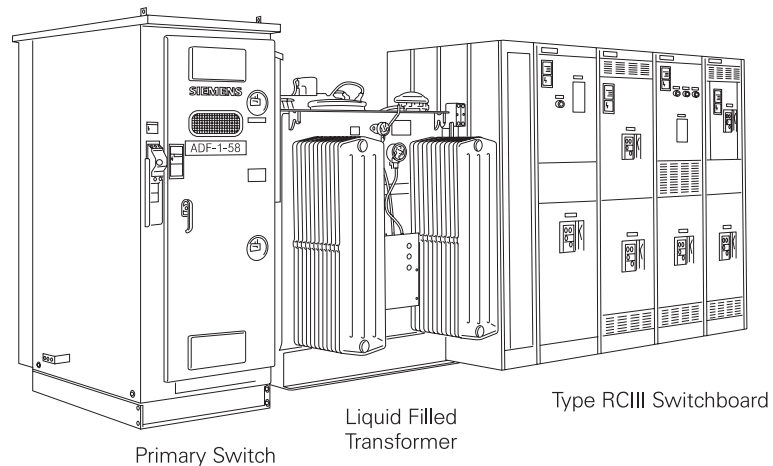

Small Industrial Facility

A small industrial facility might use a distribution scheme similar to the one shown below. In this example, transmission voltage is stepped down to 15 kV and applied to the input of the facility's secondary unit substation. The transformer located in the substation steps the voltage down to 480 volts where it is distributed to various switchboards and panelboards.

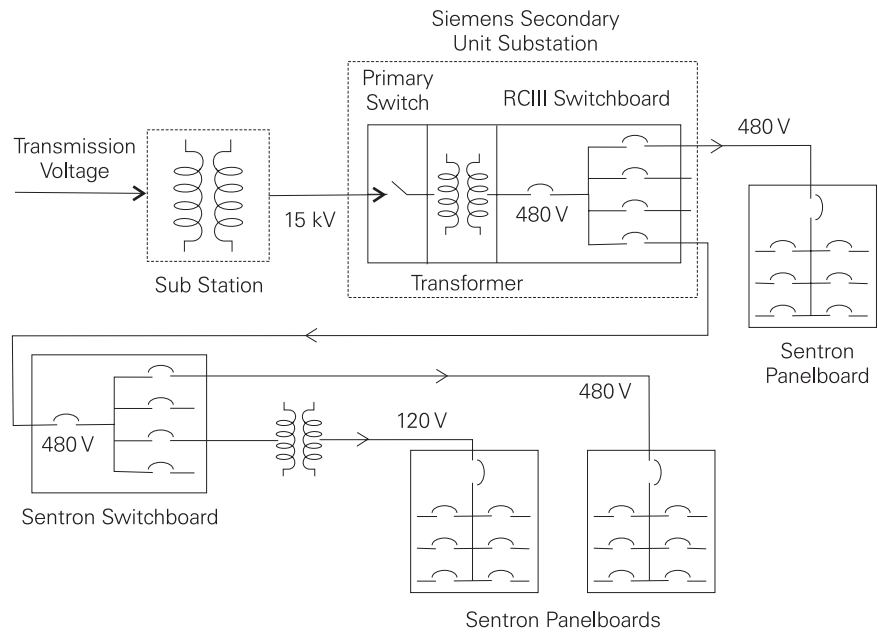

Large Industrial Facility

A large industrial facility might use a power distribution scheme similar to the one shown below. In this application power is received at the industrial facility's substation where it is stepped down to 38 kV for distribution. The distribution voltage is applied to the input of a 38 kV medium-voltage, metal-clad switchgear unit. One distribution branch is stepped down to 15 kV and applied to the input of a 15 kV switchgear unit. One of the outputs of the 15 kV switchgear is applied to the input of a secondary unit substation which uses low-voltage switchgear to distribute 480 volts throughout one section of the facility. The other outputs of the various switchgear units can be used to similarly distribute power.

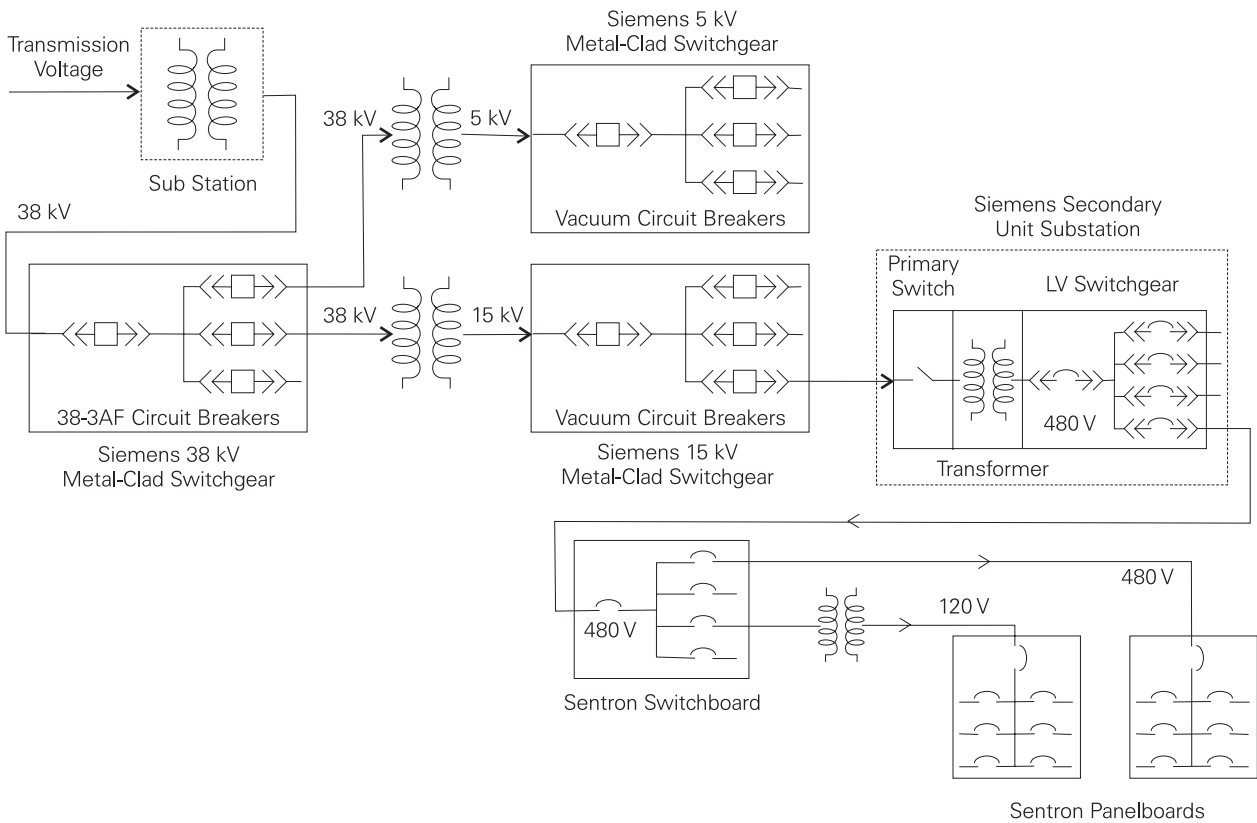

Busway

Even in large industrial facilities supply voltage must be reduced to a level that can be used by most electrical equipment. AC motors, drives, and motor control centers, for example, typically operate on 480 volts. General lighting and electrical receptacles operate on 120 volts. Busway is widely used in industrial applications to distribute this electrical power.

Types of Busway

Feeder busway is used to distribute power to loads that are concentrated in one physical area. Industrial applications frequently involve long runs from the power source to a single load. This load may be a large machine, motor control center, panelboard, or switchboard. Feeder busway sections are available in 0.125" increments from 2' to 10'.

Plug-in busway is used in applications where power requirements are distributed over a large area. Using plug-in units, load connections can be added or relocated easily. Sentron™ plug-in busway is available in 4', 6', 8', and 10' lengths.

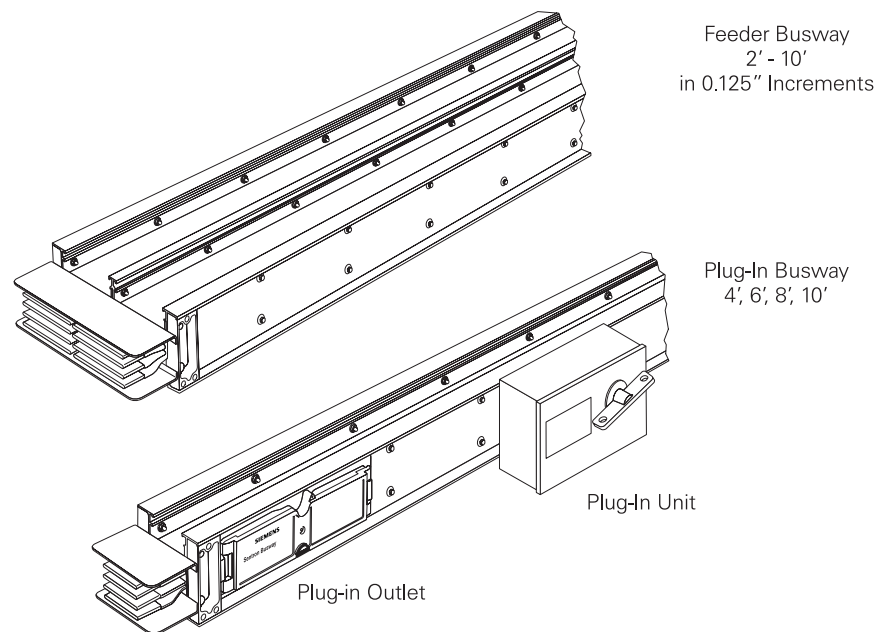

Busway runs also include a number of components such as tees, offsets, and elbows used to route busway through the facility.

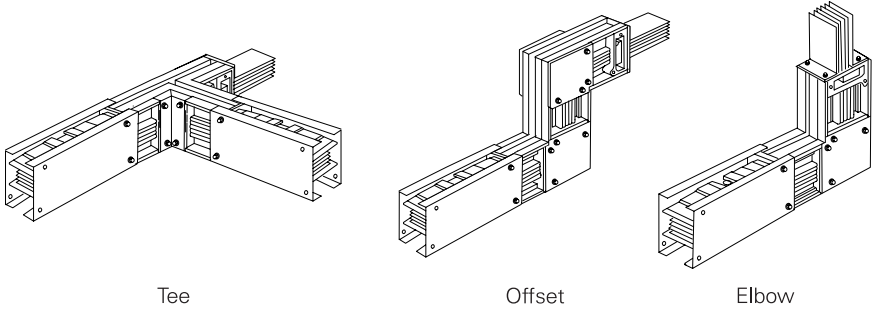

Busway Example

In this example, busway is used to transfer power from switchgear located outside a building to a switchboard located inside a building. Electrical power is then distributed to various locations in the industrial facility. Siemens Sentron busway is available with current ratings up to 5000 amps at 600 volts.

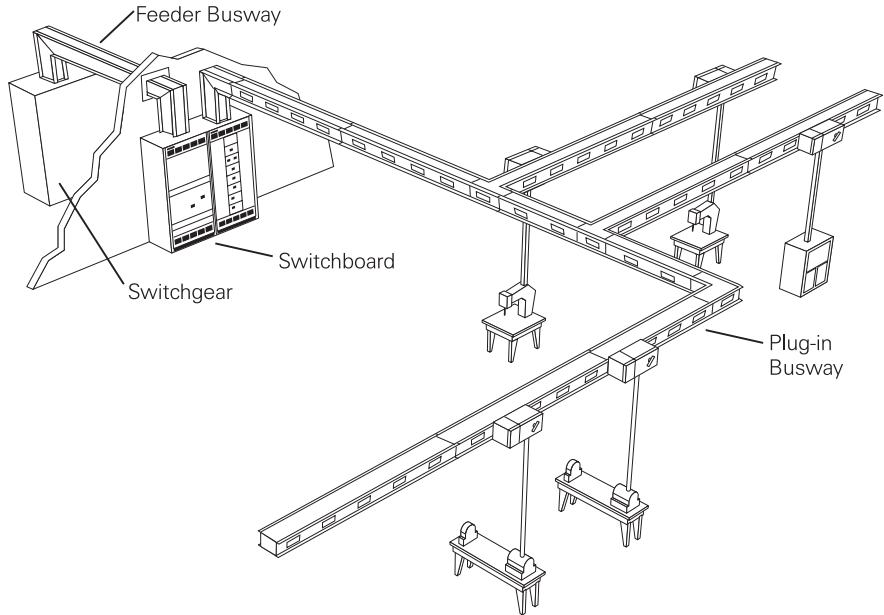

Review 3

1. Voltages less than 1000 volts are classed as _____ voltage.
2. Siemens 38 kV medium voltage, metal-clad switchgear is rated between _____ kV and 38 kV.
3. Siemens type _____ low voltage switchgear can be used outdoors.
4. The _____ section of a secondary unit substation transforms incoming voltage down to a utilization voltage.
5. _____ busway is used to distribute power to a single load that is located a long way from the power source.

Manufacturing Applications

So far, discussion in this course has primarily centered on power distribution. We have seen how Siemens products can be used to distribute power throughout residential, commercial, and industrial applications. In industrial applications, this electrical energy is also used for lighting, heating, air conditioning, office equipment, and other non-industrial systems. Unlike commercial and residential applications, however, most of the electrical energy is used to power manufacturing equipment.

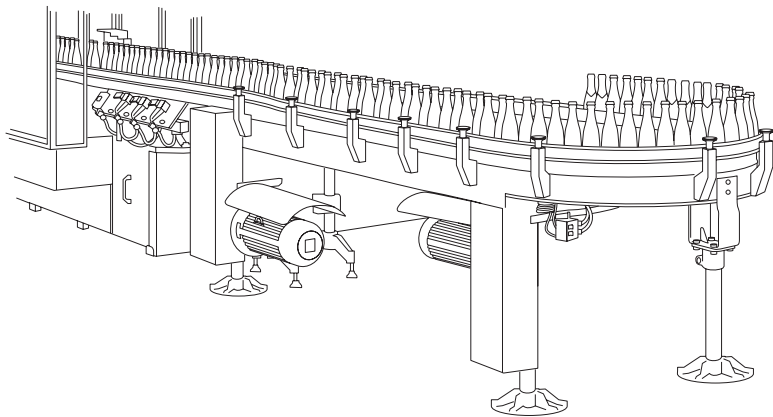

The equipment used in manufacturing varies widely depending upon the volume of production and the types of processes employed. As a result, Siemens offers a vast array of products for use in virtually every phase of manufacturing. Many of these products are purchased by machine builders or OEMs (original equipment manufacturers) for resale to the end user. In other cases, the end user may engineer a machine or process line or employ another company to do the engineering. The end result, however, is a coordinated system or process.

There is a variety of ways to represent manufacturing processes. However, since the goal of this course is to present an overview of Siemens Energy & Automation products, we need only take a high-level view of manufacturing processes.

In general, we can say that most manufacturing processes consist of one or more of the following process types:

Discrete Parts Manufacturing
Assembly
Batch Processing
Continuous Processing

The process type included in the overall manufacturing process depends upon the products being produced. Some industries, for example, are dominated by a specific process type.

<u>Process Type</u>	<u>Industry Examples</u>
Discrete Parts Manufacturing	Aircraft Parts Automotive Parts Electrical & Electronic Parts
Assembly	Aircraft Motor Vehicle Computer
Batch Processing	Food & Beverage Pharmaceutical
Continuous Processing	Chemical Petroleum

As an aid to understanding Siemens Energy & Automation products, the next section of this course will provide examples of products that could be used in each of the process types previously listed. Given the diversity of products, only representative examples will be used.

Discrete Parts Manufacturing

The process of manufacturing discrete parts typically involves the use of multiple machines. These machines may be involved with the movement and storage of raw materials, various stages of fabrication of raw materials into finished parts, packaging of parts, storage of parts, preparation of parts for shipment, and a host of related activities.

PLC-Controlled Machine

Although the various machines used as part of this process may vary widely, a typical machine will need some type of control system. This control system may be a programmable logic controller (PLC), like the Siemens S7-200 shown in the following illustration. The PLC is an industrial computer that interconnects to the machine it is controlling largely through its input-output (I/O) system. The PLC's I/O system allows it to receive inputs from switches and sensors and generate outputs to actuating devices, such as contactors and solenoids, and display devices such as indicator lights and Light Emitting Diode (LED) displays.

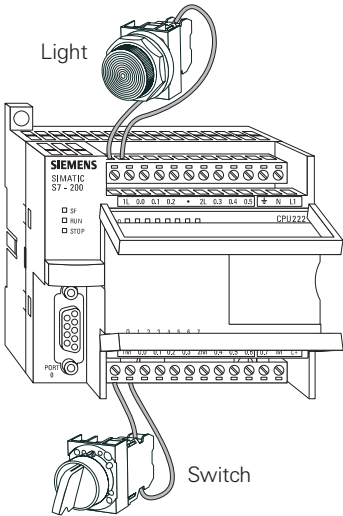

Input Devices

Inputs the PLC receives from various switches and sensors can provide signals representative of the actual condition of a machine. In addition, switches and other operator interfaces provide the PLC with signals representative of operator commands.

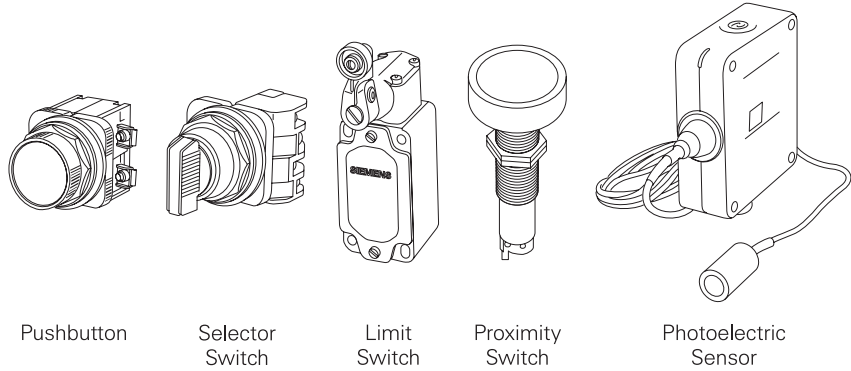

Inputs, as well as the current condition of PLC outputs and internal data values, are analyzed by the PLC's stored program.

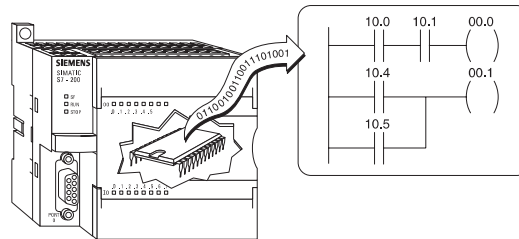

Output Devices

The PLC uses this process to determine the signals it sends to output devices that control the operation of the machine or indicate machine conditions such as RUN or STOP.

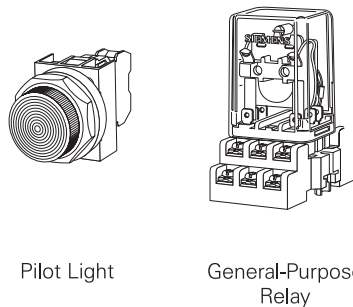

Communication

In addition to signals provided to the PLC through its I/O system, the PLC may also communicate with other devices via one or more communication ports. Communication ports can provide a pathway for the PLC to communicate with devices such as operator interfaces, variable speed drives, computers, and other PLCs.

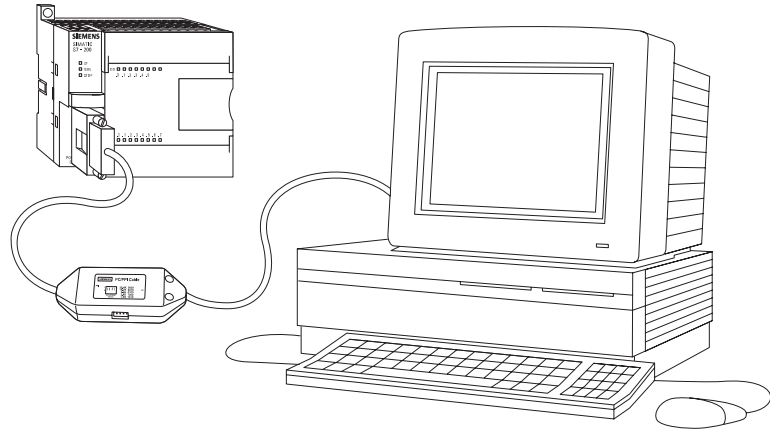

Human Machine Interface

A Human Machine Interface (HMI) is any device that acts as a link between the operator and the machine. Typically, however, the term HMI is used to refer to devices that display machine or process information and provide a means for entering data or commands. Siemens HMI products include both hardware, like the SIMATIC[®] HMI operator panels, and software, like WinCC[®].

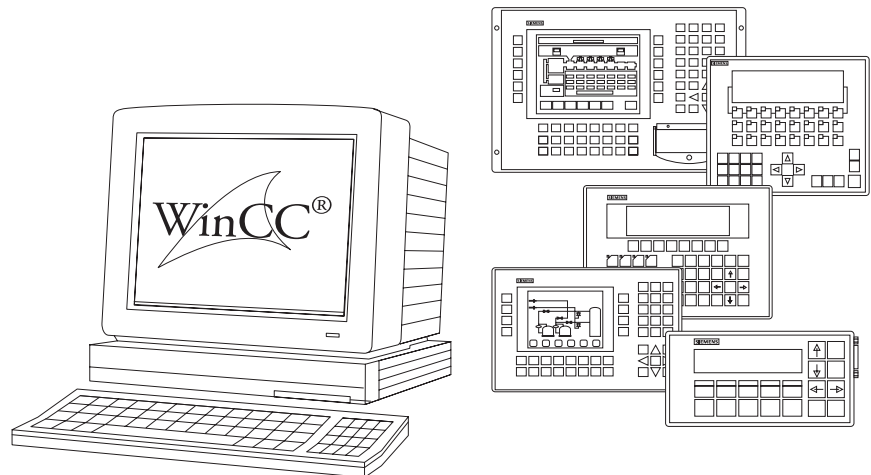

WinCC

SIMATIC HMI Operator Panels

Siemens PLCs

Since the characteristics of machines vary considerably, no one PLC can satisfy all machine control requirements. Therefore, Siemens provides PLCs of varying sizes and capabilities. The Siemens SIMATIC family of PLCs include the 505, S5, and the S7-200, S7-300, and S7-400, which are shown below.

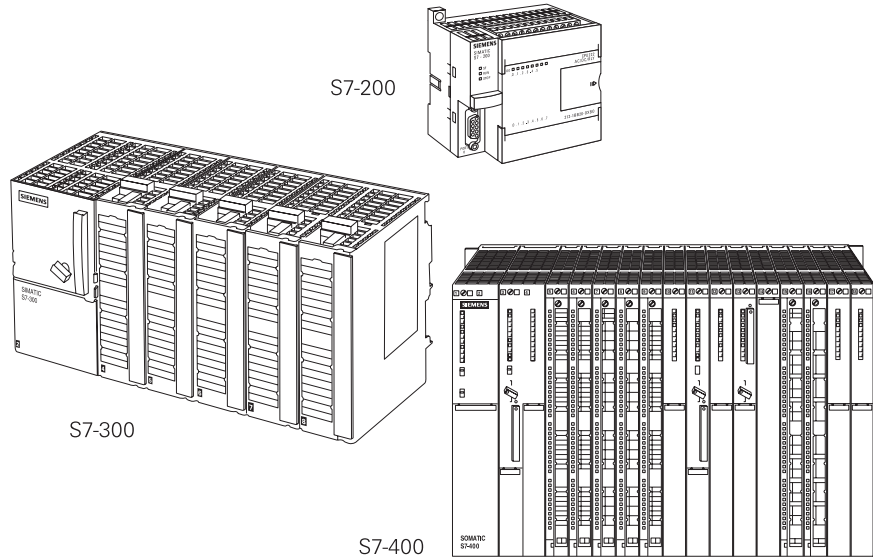

SITOP Power Supplies

Depending on the application, PLCs, operator panels, and control components may require a regulated power supply. The SITOP[®] power supply provides a regulated source of 24 VDC power and the ability to ride through momentary power dips between 3 to 10 ms. Longer ride-through times can be achieved with an optional back up module which can provide up to 100 ms at 40 amps (200 ms at 20 amps and so on). An optional DC UPS (uninterruptable power supply) module and an external battery is also available.

SITOP power supplies meet standards of agencies worldwide. They are suitable for use on worldwide networks and require no fusing on the secondary. Models are available up to 40 amps and SITOP can be used at 100% of the rated output current.

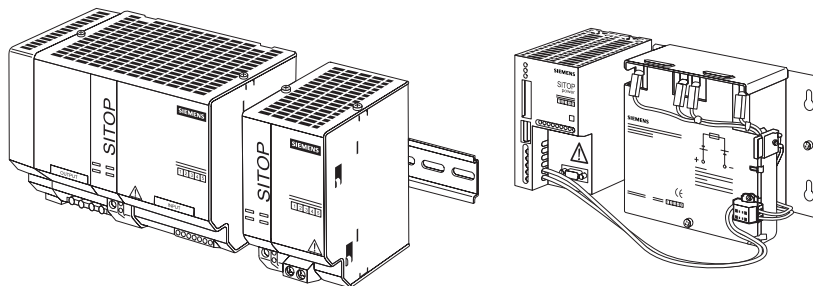

Machine Example

In the machine example shown below, an S7-200 PLC is mounted in a machine's control panel. The manufacturer of the machine has chosen to use field devices that require 24 VDC power. The power for the field devices and the PLC is provided by SITOP power supplies, one of which is shown adjacent to the S7-200.

As the S7-200 PLC executes its control program, it receives inputs from manual switches mounted on the front of the panel. It also communicates with a SIMATIC HMI OP3 operator panel that provides for manual inputs from the machine operator or maintenance person and displays alphanumeric messages indicating machine status. The PLC also receives inputs from other control devices such as limit switches or proximity switches that change state as a result of machine operations. In this example, the outputs of the PLC control electromechanical devices such as motor starters and contactors that turn on and off to control various aspects of the machine.

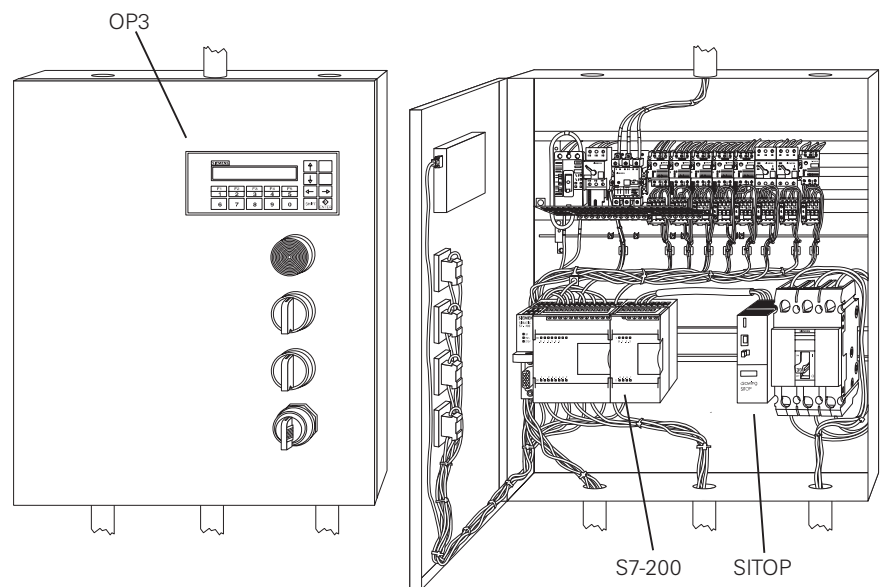

CNC-Controlled Machine Tool

PLCs are not the only control systems used for machines. Machine tools such as lathes, grinding machines, and machining centers are used to produce precisely machined parts. Machine tools typically combine a PLC control system with a computer numerical control (CNC). CNC-controlled machine tools allow parts to be machined to complex and exacting specifications. A gear, similar to the one illustrated, is one example of a part that might be made with a CNC-controlled machine tool.

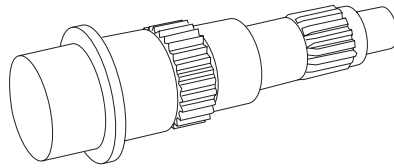

SINUMERIK

Siemens offers a range of SINUMERIK[®] CNC models such as the 810D, 840Di, 840D, and the compact FM357-2 positioning and path control module. These products provide the coordinated multi-axis control needed for milling, drilling, turning, and grinding applications. SINUMERIK CNCs also interconnect operator panels and SIMODRIVE servo and spindle drives and associated motors to form a complete control system for the machine tool.

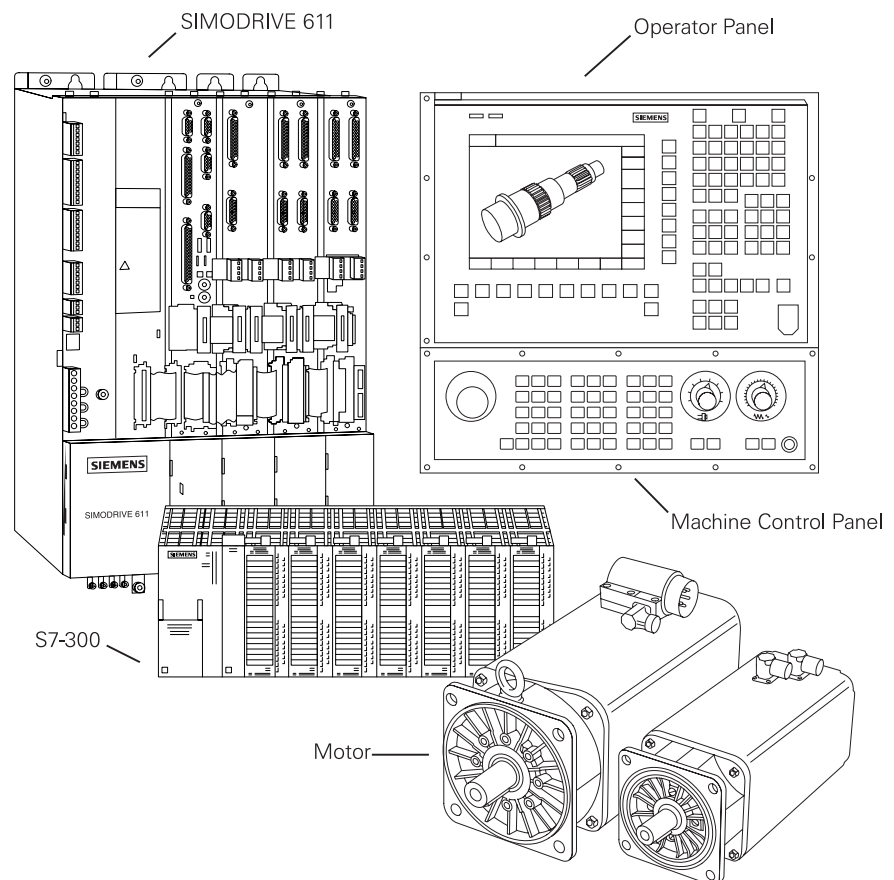

Machine Tool Example

Typically, machine tools are designed to perform a specific task, such as grinding, drilling, or cutting. Machine tools can be programmed to a predetermined pattern or model to obtain the desired shape of the finished piece. In the following example a SINUMERIK CNC controls a rotary grinding machine. The rotary grinding machine takes a piece of stock that has already been cut and shaped on another machine tool, removes any burrs or high spots, and grinds the material to a fine finish.

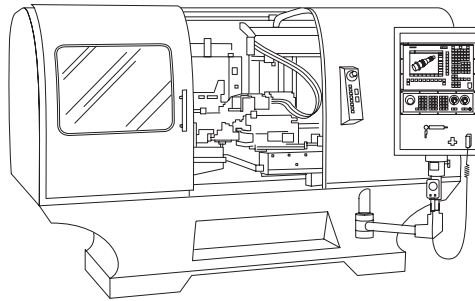

Review 4

1. A _____ is an example of an output device used for a PLC.
 - a. pushbutton
 - b. pilot light
 - c. photoelectric sensor
 - d. limit switch
2. The term "SIMATIC HMI" is used to identify a type of _____ manufactured by Siemens.
 - a. PLC
 - b. power supply
 - c. operator panel
 - d. machine tool
3. SITOP power supplies provide a regulated source of _____ VDC.
4. _____ is a Siemens trade name that identifies a complete control system used in the machine tool industry.

Assembly Processes

Assembly processes may involve assembling an entire system or subsystem at one location. In many cases, however, parts may be mounted sequentially through a series of assembly stations. Units being assembled are then moved from station to station via some type of transporter mechanism such as a conveyor. Any specific assembly station may utilize only manual assembly operations or may include one or more machine operations. The latter is particularly true when just-in-time manufacturing techniques requiring parts to be manufactured as needed are employed.

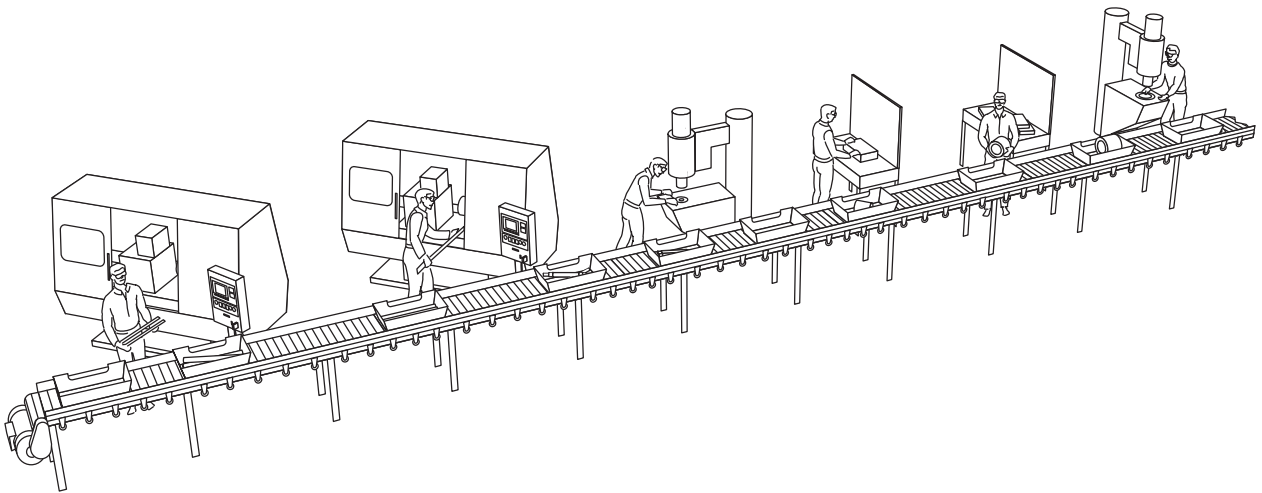

Motors

There are many aspects of assembly processes that are similar to discrete parts manufacturing and, in fact, many factories combine both types of processes. Therefore, it should come as no surprise that the electrical products used in both types of processes are often the same. For instance, AC motors are used in both types of processes to change electrical energy into mechanical energy, the reverse of what a generator does. In the U.S. the most common type of industrial motor is a NEMA frame size, three-phase AC induction motor. The term "NEMA frame size" is used to indicate that the motor corresponds to frame dimensions specified by the National Electrical Manufacturers Association. Siemens manufactures a variety of motors, including motors too large to correspond to NEMA frame dimensions (above NEMA motors) and motors that correspond to International Electrotechnical Commission (IEC) specifications.

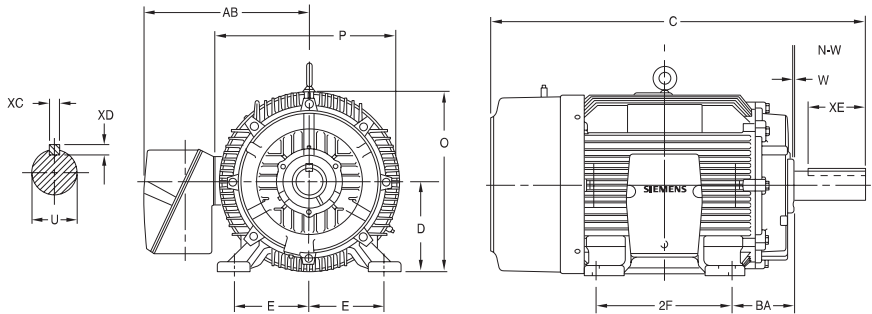

NEMA Motor

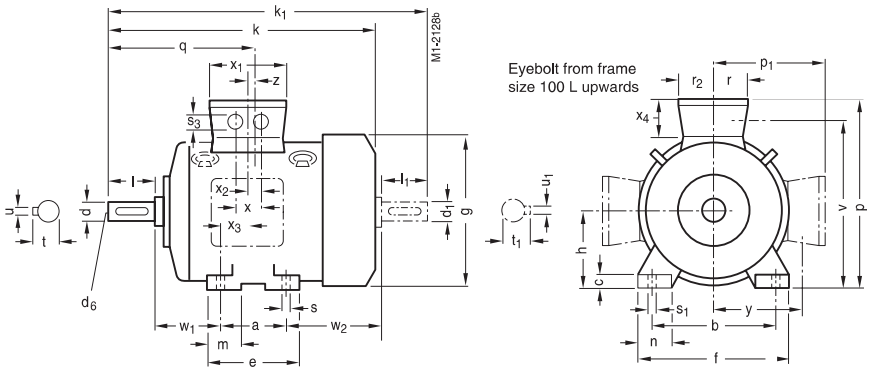

IEC Motor

Motor Control

Wherever motors are used, they must be controlled. The most basic type of AC motor control involves turning the motor on and off. This is often accomplished by using a motor starter, which is made up of a contactor and an overload relay. The contactor's contacts are closed to start the motor and opened to stop the motor. This is accomplished electromechanically using start and stop pushbuttons or other pilot devices wired to control the contactor. The overload relay protects the motor by disconnecting power to the motor when an overload condition exists. An overload could occur, for instance, when a conveyor is jammed. Although the overload relay provides protection from overloads, it does not provide short-circuit protection for the wiring providing power to the motor. For this reason, a circuit breaker or fuses are also used.

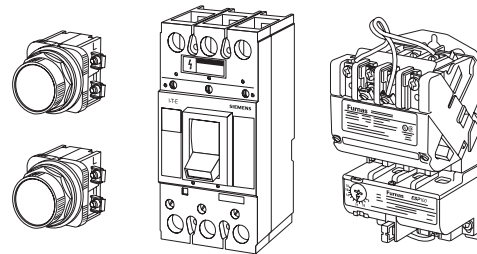

Pushbuttons Circuit Breaker Motor Starter

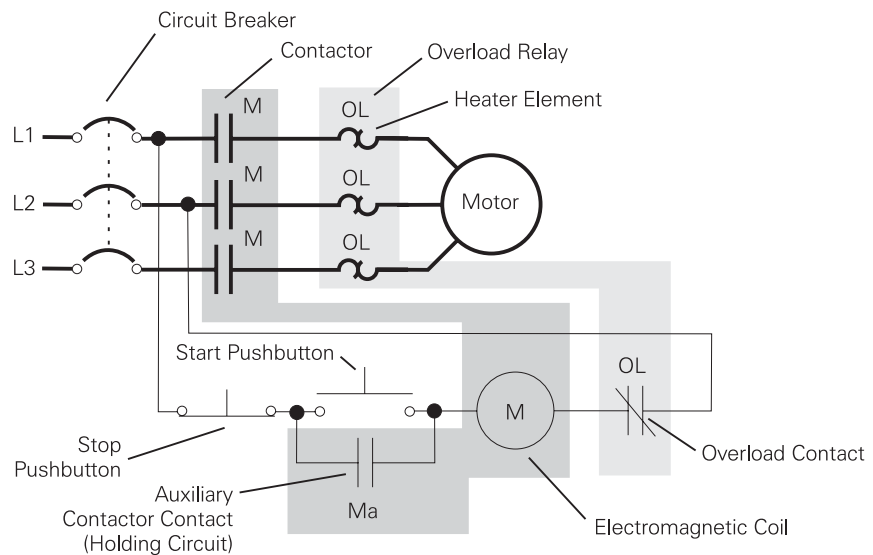

Motor Control Centers

When only a few geographically dispersed AC motors are used, the circuit protection and control components may be located in a panel near the motor. When a larger number of motors are used these components are often concentrated in a motor control center. A motor control center is a type of enclosure that is sectionalized so that control circuits associated with each motor are mounted in a removable container called a pan or bucket. Siemens TIASTAR motor control centers can be manufactured to fit a wide range of customer requirements. Motor control centers can also include items such as reduced-voltage controllers, variable speed drives, and PLCs.

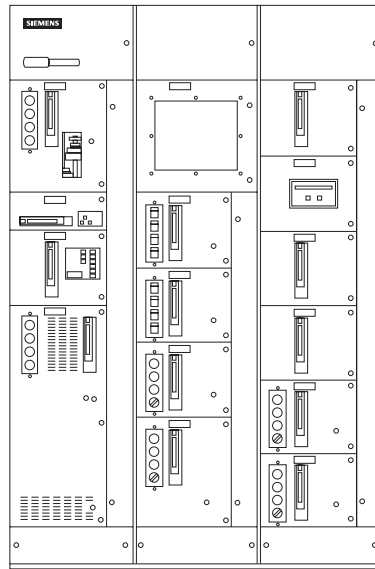

Reduced Voltage Controllers

While it is common to turn motors on and off instantaneously, this abrupt transition results in power surges and mechanical shock that may need to be avoided especially when larger motors are involved. Solid-state reduced-voltage controllers, however, can apply voltage gradually from an initial low voltage to 100% voltage. The motor experiences reduced inrush current and speed is accelerated smoothly. In addition, just enough torque can be applied to start and accelerate the motor. This is beneficial for loads that have problems with the initial jerk and rapid acceleration of across-the-line starting. Reduced-voltage controllers, such as the Siemens SIRIUS and SIKOSTART, can also be included in Siemens motor control centers.

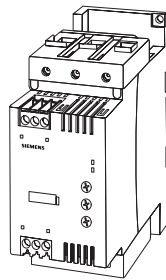

SIRIUS

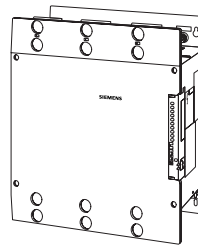

SIKOSTART

AC Drives

Although reduced voltage controllers can control an AC motor during starting and stopping, many applications require control of motor speed and torque. Controlling motor speed and torque is the job of a variable speed drive. Since AC motors are available in a range of ratings and types, Siemens offers a broad range of AC drives, including multiple models of the MICROMASTER and MASTERDRIVE.

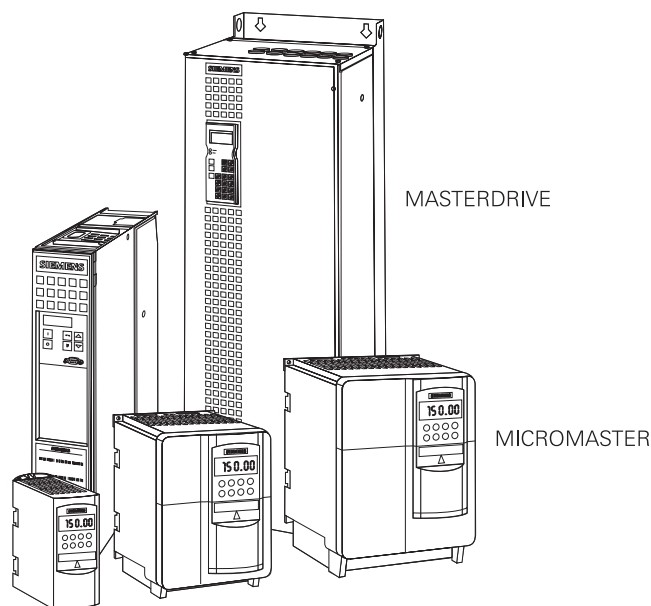

DC Drives

Although AC motors are more commonly used, many factories also use DC motors for selected applications. In many of these applications, precise control of motor speed and torque is required. For these applications Siemens offers the SIMOREG® DC MASTER.

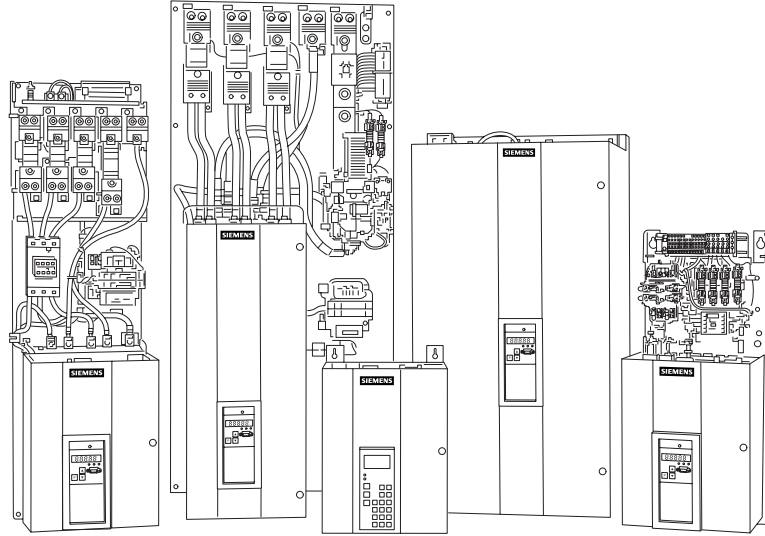

PLCs

Since assembly processes vary in complexity, the types of control systems and related devices employed will also vary. In addition to small- and medium-sized PLCs or other control systems used to control individual machines, one or more larger PLCs may be employed to collect data and coordinate operation of some or all of the system. This overall coordination may include control of the full range of motor control devices discussed thus far from full-voltage starters to AC and DC drives. The specific PLC model used will be determined by the size and complexity of the application. Examples of Siemens PLC models that may be employed include the S7-300 and S7-400.

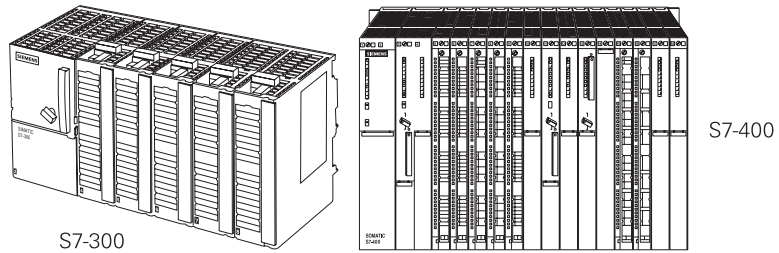

Human Machine Interface

Just as it is often necessary to use a PLC to coordinate the operation of multiple machines in an assembly process, it is also often necessary to provide a graphical representation of the current status of this process. In addition to providing this graphical representation, a Human Machine Interface (HMI), such as Siemens WinCC, can provide a custom interface to allow operation personnel to control some or all of the process and for maintenance personnel to obtain system diagnostic information.

Since many manufacturing facilities use multiple PLC models and often models produced by multiple companies, WinCC can communicate with many types of PLCs. In addition, WinCC versions are available for computers using Windows 95 or Windows NT operating systems.

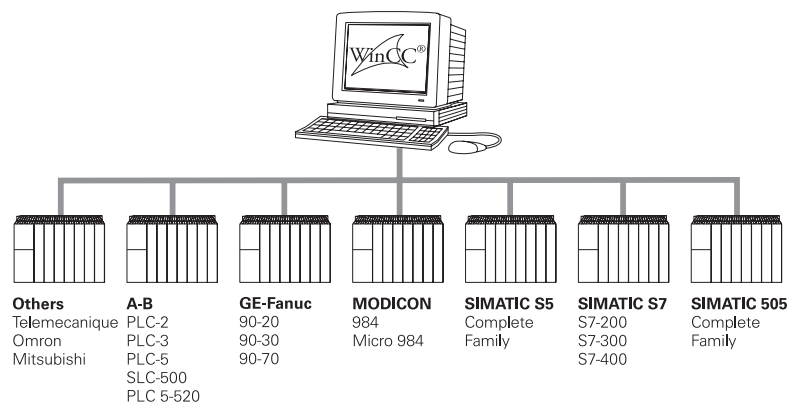

Local Area Network

In any complex assembly process the need for rapid information flow is critical. Conditions at any point in the process may impact the entire process. This need for information flow often requires that intelligent devices such as PLCs, intelligent sensors, drives, computers, and operator interface systems be interconnected by one or more local area networks (LAN).

A LAN is a communication system designed for private use in a limited area. LANs are used in office areas as well as in manufacturing environments; however, LANs used in industrial applications must be able to operate reliably in conditions that might be unsuitable for office-grade equipment. Industrial environments typically have a high level of electrical noise and a greater range of temperature and humidity than found in office environments.

Specifications for industrial LANs vary considerably depending upon the requirements of the application. Issues such as the amount of data to be communicated, the rate at which data must be communicated, the number of devices to be connected, the reliability and noise immunity required, compatibility with other networks, and cost are examples of important considerations. In general, it is not possible for one network type to maximize all characteristics. For instance, a network that can communicate a large amount of data in a short time is likely to be more expensive than a network that has more limited requirements. Therefore, many factories use a multi-level structure for communication.

In the past, these networks were often proprietary systems designed to a specific vendor's standards. Siemens has been a leader in pushing the trend to open systems based upon international standards developed through industry associations. Examples of these open networks are listed below.

Network Level	Examples	Examples of Devices or Systems Connected
Management Level	Ethernet	Computers Running Management Information Systems (MIS)
Control Level	Ethernet	PLCs, Industrial Computers
Field and Process Level	PROFIBUS FMS PROFIBUS DP PROFIBUS PA	PLCs, CNCs, Variable Speed Drives HMI's, Industrial PCs
Device Level	Actuator Sensor Interface (ASI)	Actuators (Output Devices), Sensors (Input Devices)

Batch and Continuous Processes

Thus far, we have discussed equipment used in discrete parts manufacturing or assembly applications. In addition to these types of manufacturing processes, electrical equipment is also used to manufacture a variety of products using batch or continuous processes.

Batch Processes

Batch processes are familiar to most people since we use them in everyday life. For instance, when we bake a cake, we follow a recipe that involves adding ingredients, stirring the mixture, pouring it into baking pans, putting the pans into the oven for a specific time at a specific temperature, etc. Industrial batch processes are similar to the process of baking a cake but scaled up to produce a larger quantity of material. A variety of products are produced using batch processes. Food, beverages, pharmaceutical products, paint, fertilizer, and cement are a few of the categories of products produced using batch processes. Some products such as food, beverages, and pharmaceuticals require precise tracking of batch information for safety and regulatory purposes.

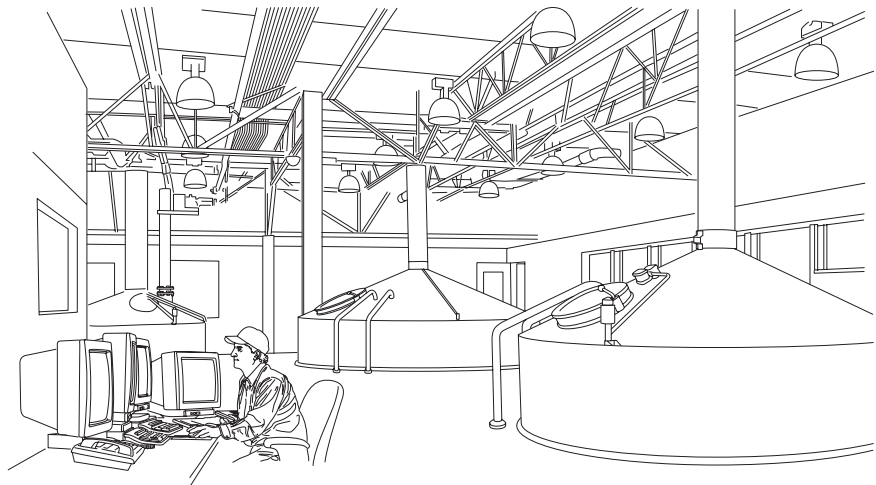

Continuous Processes

Continuous processes are less understood by most people; however, they have some similarities to batch processes. Ingredients must be combined in precise ways at precise points in the process. Precise control of process conditions must be maintained to ensure product quality and safety of operations. Some industries, such as chemical and petrochemical industries, use continuous processes extensively. Many other industries, however, use continuous processes as some part of their operations, purifying air and water, treating waste products, etc.

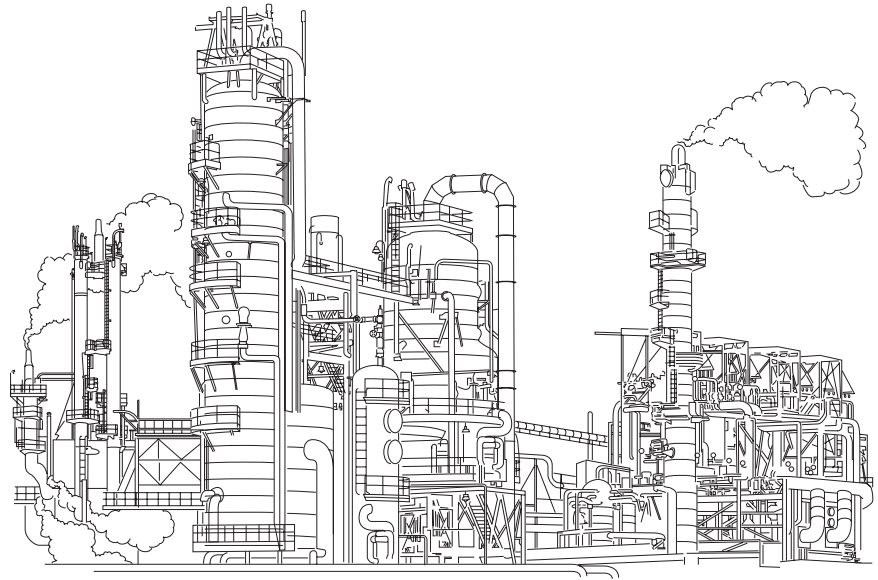

Both batch and continuous processes use many of the products discussed thus far. However, there are some unique characteristics of batch and continuous processes that either require the use of additional types of equipment or require some of the equipment previously discussed to be applied differently.

Closed-Loop Control

One characteristic of batch and continuous processes is their extensive use of analog data. Analog values can vary continuously within a specified range. The analog data may be representative of temperature, pressure, rate of flow, weight, thickness, viscosity, humidity, or any other characteristic of importance to the process. Both batch and continuous processes require continuous monitoring at numerous points throughout the process. In addition, a corrective action is often required to insure that the process stays within specifications. This type of control that involves measuring a value, comparing the measured value to a desired value or set point, and correcting for the error is called closed-loop control.

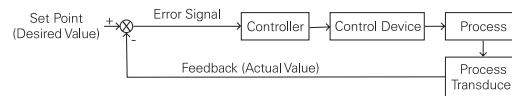

A variety of approaches can be used for process control depending upon the complexity of the process being controlled. A small batch process often lends itself well to control by one PLC or a few networked PLCs. A representation of the process showing its current status and a history of data recorded at various points in the process is often provided to an HMI system networked to the PLCs.

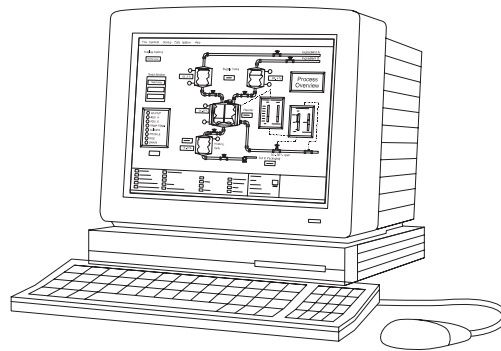

Increasingly, variable speed drives are also networked to the PLC and HMI systems. These drives are used to control the speed of pumps or fans that in turn control the flow of fluids and gases. Flow control is frequently accomplished by using control valves and vent damping systems to regulate flow while running pump and fan motors at full voltage. Using variable speed drives for pump and fan control is a more energy efficient approach to controlling process flow rates.

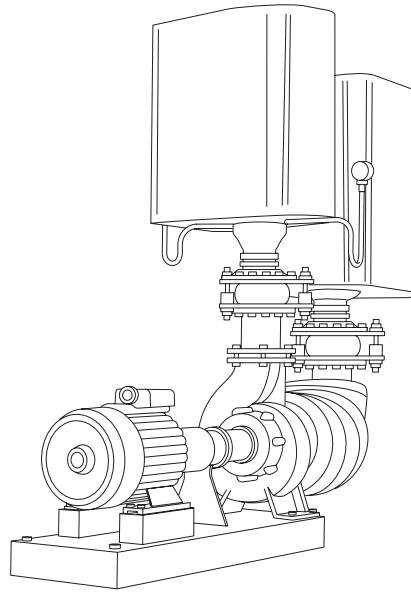

Supervisory Control

Traditionally, medium to large applications in process industries have been controlled by distributed control systems (DCS) that are based on proprietary hardware and software. By utilizing industrial standards (Microsoft NT, Ethernet, PROFIBUS) the industry now moves towards scalable hybrid systems, like SIMATIC PCS 7. Hybrid systems contain powerful process controllers and networks combined with all software tools integrated into one common Engineering system. By using PCS 7, customers reduce engineering time, installation costs and spare part inventory. PCS 7 is built upon Totally Integrated Automation components and provides a complete toolset for developing the control strategy, the HMI, networks and interfaces to MES/ERP systems.

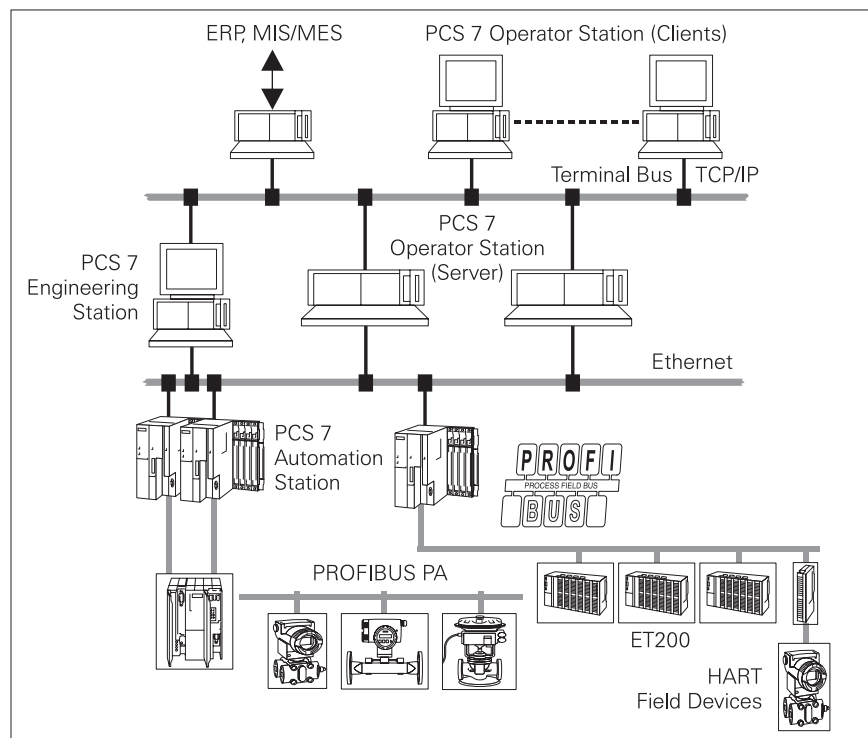

Other STEP 2000 Courses

Hopefully, this course along with our STEP 2000 Basics of Electricity course, has provided you with a base of knowledge that will make our other STEP 2000 courses more useful and interesting to you. Keep this book handy so that you can use the pictorial glossary to assist you in your additional training or with your daily work.

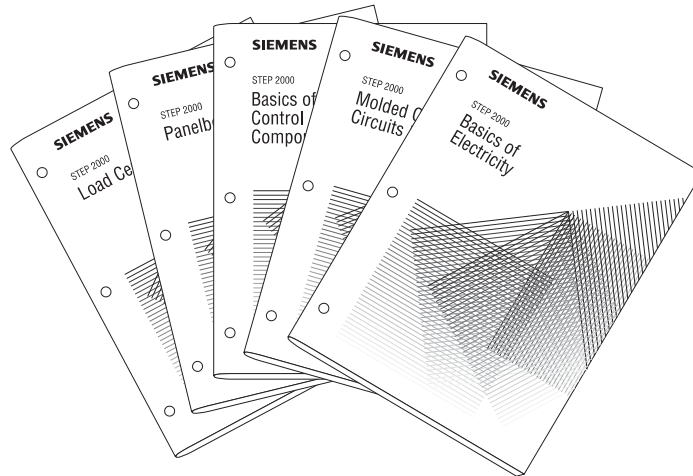

Review 5

1. _____ controllers start a motor by applying voltage gradually from an initial low voltage to 100% voltage.
2. An AC or DC _____ is used to control the speed and torque of a motor.
3. _____ is a name associated with three types of LANs that are used at the field and process level.
4. _____ is an example of a LAN that is used at the device level.
5. Paint, fertilizer, and cement are examples of _____ processes.
6. _____ - _____ involves measuring a value, comparing the measured value to a desired set point, and correcting the error.

Pictorial Glossary

The pictorial glossary includes definitions and illustrations to many terms that are frequently used in the electrical industry. Terms that are underlined and italicized are included in the glossary as a separate definition.

AC Drive

An electronic device used to control the speed and *torque* of an *AC motor*. Also called a *variable frequency drive*, *variable speed drive*, and an *inverter*.

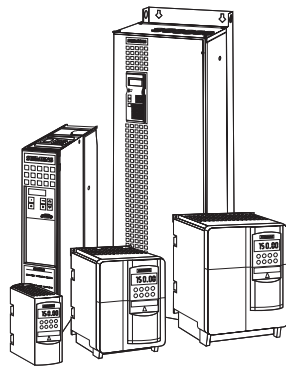

AC Motor

A *motor* that uses *alternating current* to convert electrical energy into mechanical energy. Many AC motors used in industrial applications are three-phase induction *motors*.

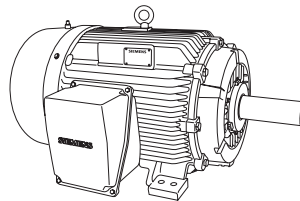

Alternating Current (AC)

Current that periodically reverses direction.

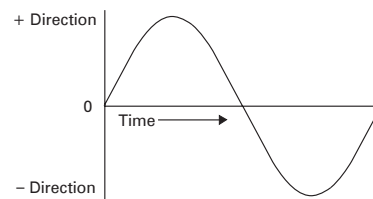

Ambient Temperature

The temperature of the medium (air, water, etc.) surrounding a device.

American National Standards Institute (ANSI)

A nongovernmental organization that promotes and coordinates the development of standards and approves standards written by other organizations.

American Standard Code for Information Interchange (ASCII)

A seven-*bit* code, sometimes with an additional parity bit added for error checking. The ASCII code is used to represent numbers, letters, symbols, and control codes.

American Wire Gage (AWG)

A common method of specifying wire size (cross-sectional area). Larger numbers represent smaller wires. After AWG No. 1, the largest sizes are AWG No. 0, AWG No. 00, AWG No. 000, and AWG 0000. AWG No. 0 is called one-aught, AWG No. 00 is called two-aught, etc.

Ammeter

A meter designed to measure *current*.

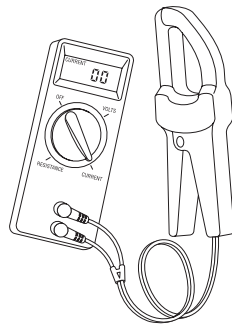

Ampacity

The rated continuous *current* capacity of a conductor or device.

TABLE 1-Ampacities of Insulated Conductors (From NEC Table 310-16)
Not More Than Three Insulated Conductors in Raceway
(Based on Ambient Temperature of 30°C, 86°F)

Size	COPPER CONDUCTORS			
	60°C (140°F)	75°C (167°F)	85°C (186°F)	90°C (194°F)
AWG MCM	TYPES ①	TYPES ②	TYPES	TYPES
		RH RHW RUH THW THWN XHHW USE ZW	V, MI	TA, TBS SA, AVB SIS FEP, ③ FEPB, ④ RHH, ⑤ THHN, ⑥ XHHW, ⑦
18	---	---	---	14
16	---	---	18	18
14	20 ⑧	20 ⑧	25	25 ⑧
12	25 ⑧	25 ⑧	30	30 ⑧
10	30	35 ⑧	40	40 ⑧
8	40	50	55	55
6	55	65	70	75
4	70	85	95	95
3	85	100	110	110
2	95	115	125	130
1	110	130	145	150
1/0	125	150	165	170
2/0	145	175	190	195
3/0	165	200	215	225
4/0	195	230	250	260

Ampere, Amp

The basic unit for *current*. The ampere, also called an amp, is equal to a current of 1 *Columb* per second. The symbol for ampere is "A."

Amplitude

The total variation of a waveform. Amplitude can be expressed as a peak value, peak-to-peak value, or *effective value*.

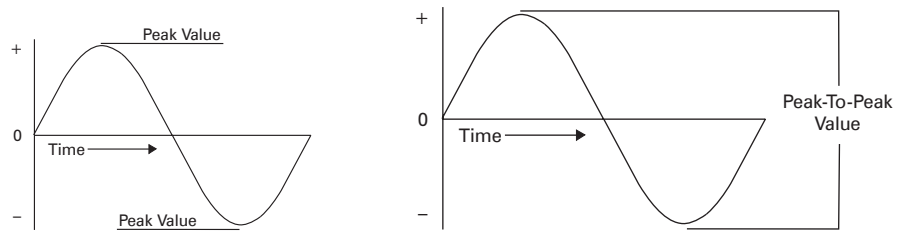

Analog

A value that is continuously variable. Also used to describe circuits that work with analog signals.

Analog Input

An input to a system that can continuously vary over a range of *current* or *voltage* such as 4 to 20 milliamps or 0 to 10 volts.

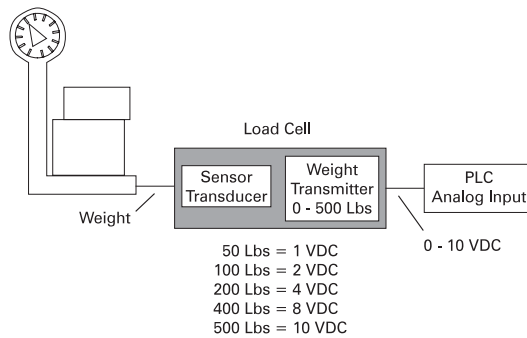

Analog Output

An output from a system that can continuously vary over a range of *current* or *voltage* such as 4 to 20 milliamps or 0 to 10 volts.

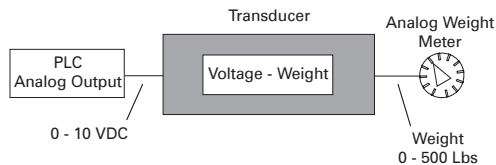

Analog-to-Digital (A/D) Converter

A circuit that converts *analog* signals to signals that can be used by *digital* circuits.

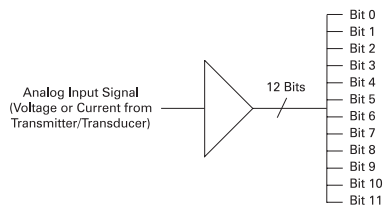

Apparent Power

The vector sum of true power and reactive power. Apparent power is calculated by multiplying current times voltage. The unit for apparent power is the volt-ampere or VA.

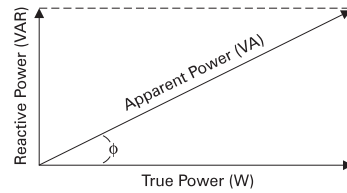

Arc Chute Assembly

An assembly of metal plates surrounding circuit breaker or contactor contacts. The arc chutes are used to reduce contact damage by quickly extinguishing the arc created when circuit breaker contacts open.

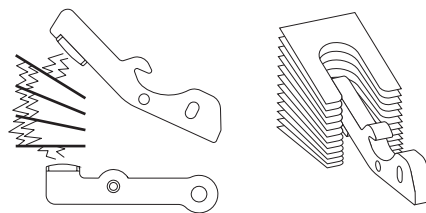

Arc Fault

An arc fault occurs when a current-carrying conductor has arcing condition to ground or another conductor.

Arc Fault Circuit Interrupter (AFCI)

A circuit breaker designed to provide protection from the effects of an arc fault by recognizing the characteristics unique to arcing and de-energizing the circuit when an arc fault is detected.

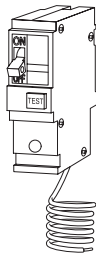

Autotransformer

A type of transformer in which the secondary coil is part of the primary coil. Often the secondary voltage is adjustable via a movable tap.

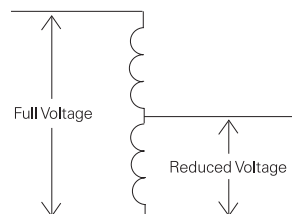

Baud Rate

A way of describing the amount of data that can be sent on a signal line. Often used synonymously with *bits* per second; however, baud rate was originally intended for use in telegraphy application to refer to signal events per second.

Binary-Coded Decimal (BCD)

Usually refers to the 8-4-2-1 code where four *bits* are used to represent decimal digits 0 through 9.

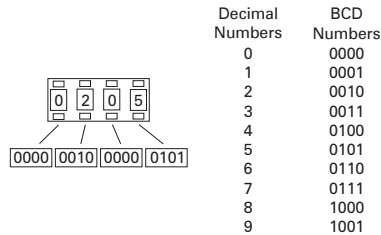

Binary Number

A number made up only of 1's and 0's that represent powers of two (2). *Digital* equipment uses binary numbers to represent numerical values or the on or off condition of devices.

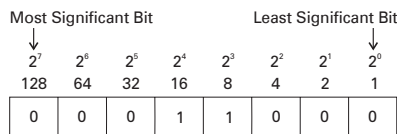

Bit

A 1 or 0 representing one position in a *binary* number.

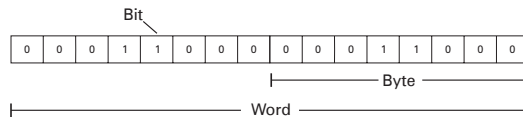

Bonding

The permanent joining of metal parts to form an electrically conductive path.

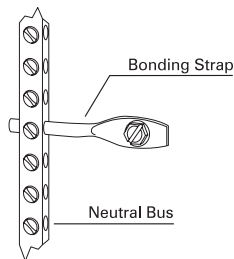

Branch Circuit

A part of a power distribution system extending beyond the final overcurrent protection device.

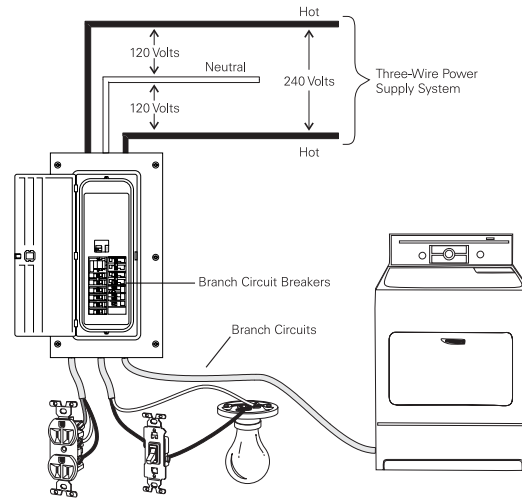

Bus

A group of conductors used to supply power, data, or control signals downstream.

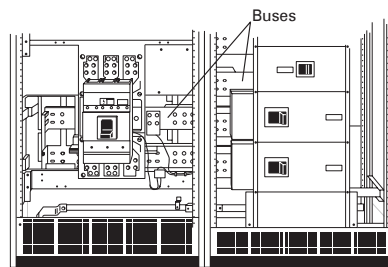

Bus Bar

A conductor that serves as a common connection for two or more circuits.

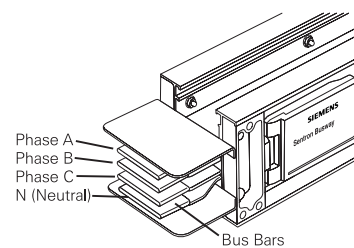

Bus Plug

A device used with plug-in busway to allow power to be distributed to a load.

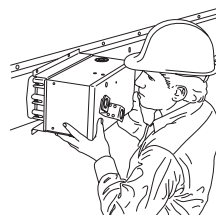

Busway

A prefabricated electrical distribution system that uses bus bars in its own protective enclosure.

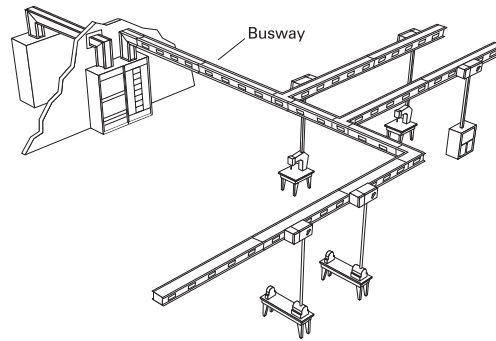

Busway Hangers

Devices used to suspend busway from a ceiling or mount it to a wall.

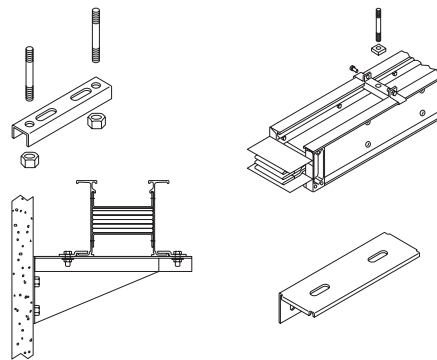

Byte

Eight consecutive bits.

Capacitance

The property of a circuit that allows it to store an electrical charge. The symbol for capacitance is "C." The unit for capacitance is the farad.

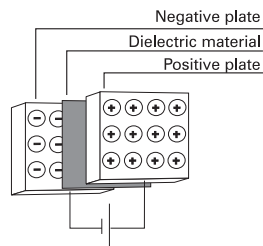

Capacitive Proximity Sensor

A type of sensing switch that produces an electrostatic field to detect the presence of metal and nonmetallic objects without coming into contact with them.

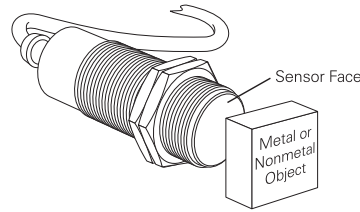

Capacitive Reactance

The opposition to alternating current resulting from circuit capacitance. Capacitive reactance is inversely proportional to frequency and capacitance. The symbol for capacitive reactance is "Xc." The unit for capacitive reactance is the ohm.

$$X_c = \frac{1}{2\pi f c}$$

Capacitor

A device manufactured to have a specific capacitance.

$$C = K \frac{A}{d}$$

— Area of plates
— Distance between plates
— Dielectric constant

Central Processor Unit (CPU)

The decision-making part of a computer. May also be used to describe the processing circuits together with memory and other circuits needed for processing information.

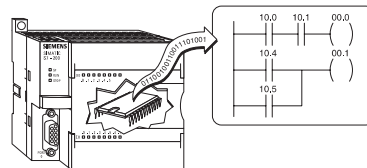

Circuit Breaker

A device that can be used to open or close a circuit manually and can also open a circuit automatically when current is excessive.

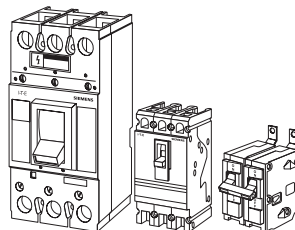

Closed-Loop Control

A control technique that compares a *feedback* signal representative of an actual value with a desired value and responds to minimize the error.

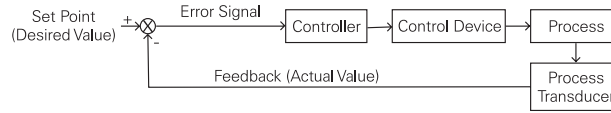

Conductor

A material that permits many electrons to move through it. Copper, silver, and aluminum are examples of materials that are good conductors. Also used generically to refer to a wire, cable, or *bus bar* that is made from a conducting material.



Contactors

A device used to energize and de-energize an electrical circuit.

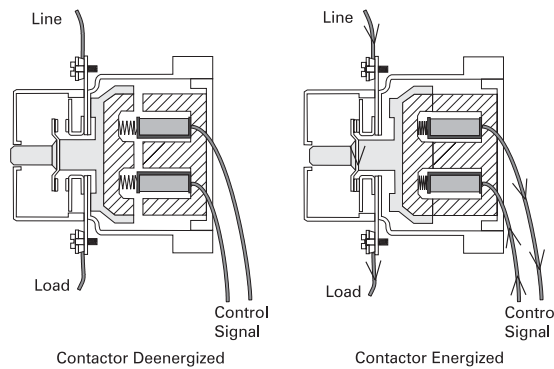

Control Relay

A device used to remotely open and close contacts.

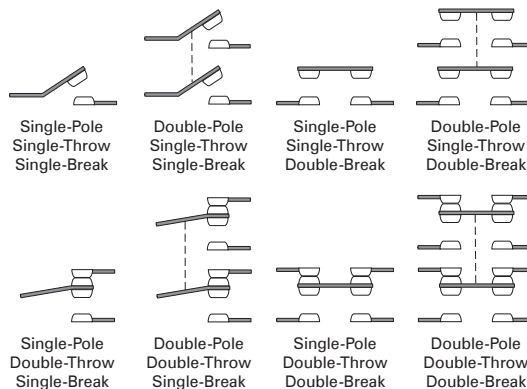

Coulomb

A unit of electrical charge equal to 6.24×10^{18} electrons.

Coulomb's Law

A law that states that charged objects attract or repel each other with a force that is directly proportional to the product of their charges and inversely proportional to the square of the distance between them. Unlike charges attract, and like charges repel each other.

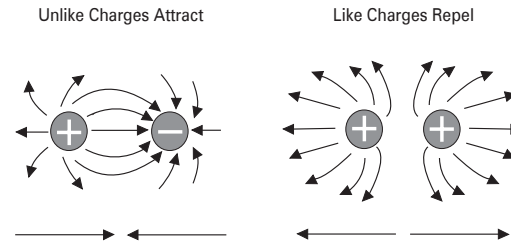

Counter emf

A voltage created in an inductive circuit that opposes a change in current flow.

Crest Factor

A ratio of the peak value of an alternating current source to the effective value.

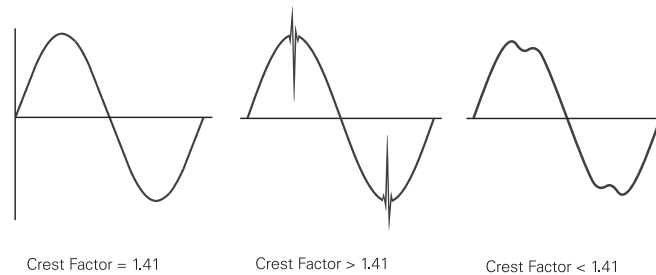

Current

The flow of electrons in a circuit. Current is designated by the symbol "I" and is measured in amperes.

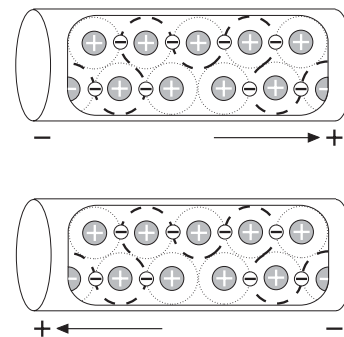

DC Drive

An electronic device used to control the speed and torque of a DC motor. Also called a variable speed drive or an adjustable speed drive.

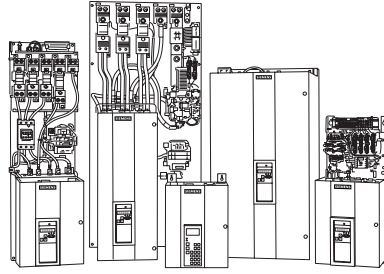

DC Motor

A motor that converts direct current electrical energy into mechanical energy.

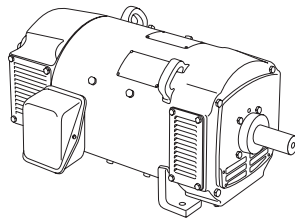

Dead Front

A front portion of a panelboard or switchboard that limits exposure to electrical connections.

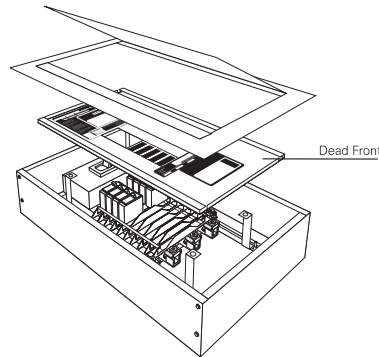

Delta

A connection arrangement used for the primary and/or secondary of a three-phase transformer.

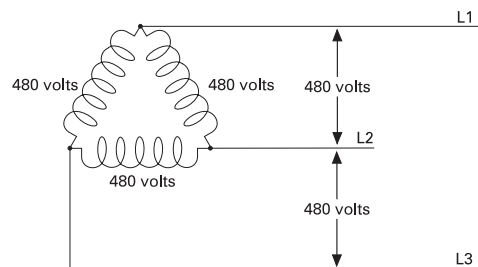

Digital

Used to describe circuits that use on or off (binary) signals. Also used to describe equipment that includes these circuits.

Digital-to-Analog (D/A) Converter

A circuit that converts *digital* signals to signals that can be used by *analog* devices.

DIN

DIN is the German Institute for standardization. DIN has been recognized since 1975 as the standards organization that represents German interests nationally and internationally.

DIN Rail

A mounting bracket manufactured to *DIN* specifications. Typically used to mount devices such as small *PLCs*, *motor starters*, relays, and other components that are *DIN* rail compatible.

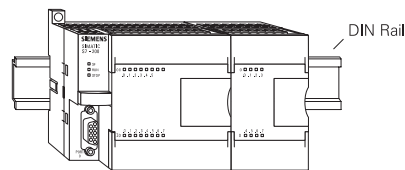

Diode

A component with two terminals (anode and cathode) that passes *current* primarily in one direction. Often used as part of a *rectifier* circuit.



Direct Current (DC)

Current with a constant direction.

Disconnect Switch

A switch designed to disconnect electrical *power* from a circuit.

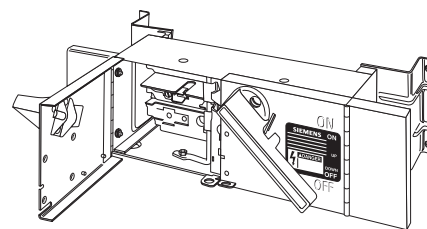

Discrete Input

An input that is either on or off.

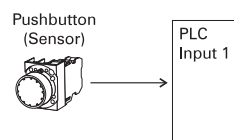

Discrete Output

An output that is either on or off.

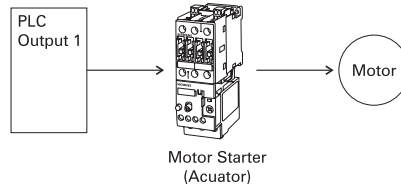

Distribution Section

A section of switchboard that receives power from the service section.

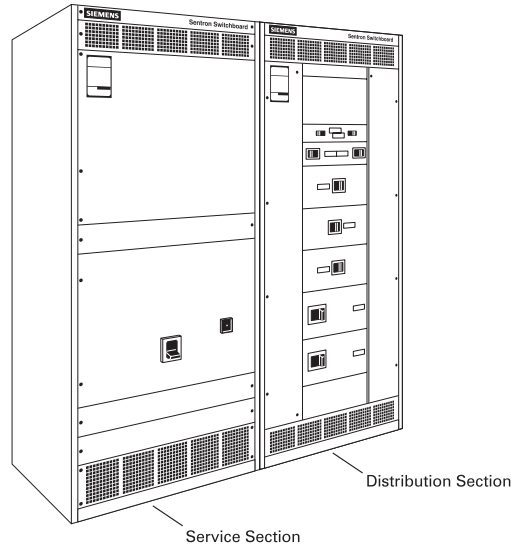

Duty Cycle

The ratio of a device's on time to its total cycle time. Duty cycle is normally expressed as a percentage; therefore, a device with a 50% duty cycle is on half the time.

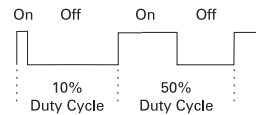

Effective Value

A measure of the amplitude of alternating current or voltage. Also called the root-mean-square or RMS value. Test meters used to measure alternating current or voltage usually display effective values.

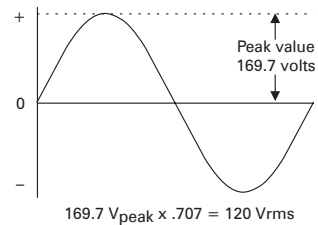

Electrically Erasable Programmable Read Only Memory (EEPROM)

A type of *semiconductor* memory often used for storage of data or programs that change infrequently. The contents of EEPROM chips are erased with electrical pulses rather than with ultraviolet light as with *erasable programmable read only memory*. EEPROMs retain their contents when power is lost.

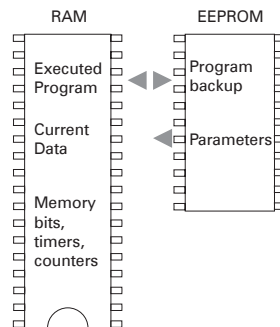

Enclosure

A case or housing. Guidelines for various types of electrical enclosures are provided by the *National Electrical Manufacturers Association (NEMA)*.

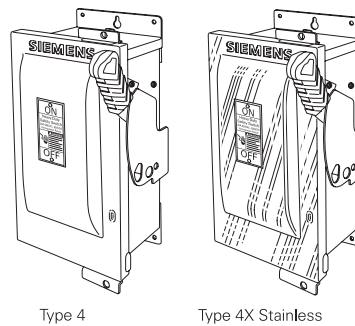

Encoder

Often refers to a *digital* device that provides angular position information. Some encoders provide this information as incremental pulses as position changes. Other types of encoders provide a digital signal representative of absolute position.

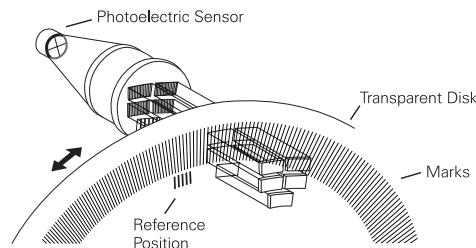

Erasable Programmable Read Only Memory

A type of semiconductor memory often used for storage of data or programs that change infrequently. EPROM chips must be removed from the circuit to be erased and reprogrammed. EEPROMS retain their contents when power is lost.

Explosion Proof (XP)

A motor enclosure type used in hazardous locations. Explosion proof enclosures are also available for other types of equipment.

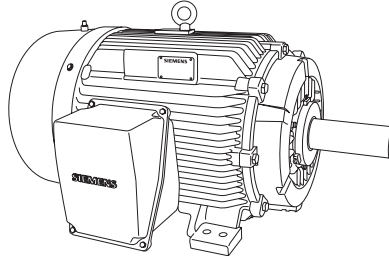

Farad

The basic unit of capacitance. The symbol for the farad is "F"

Feedback

A signal provided to a control circuit that is representative of an actual condition in a machine or process.

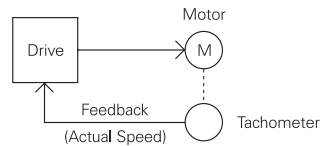

Feeder

A set of conductors that originates at a main distribution center and supplies power to one or more secondary or branch distribution centers.

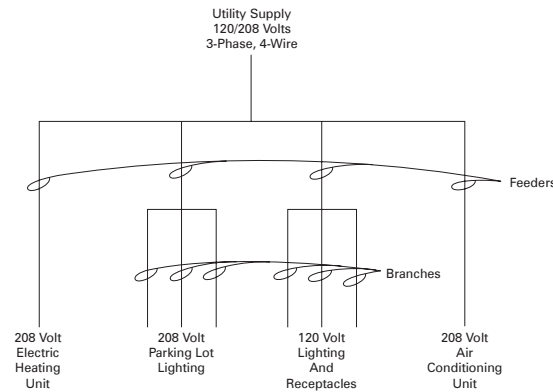

Feeder Busway

Busway used to distribute power, often over a long run, to loads concentrated in one area.

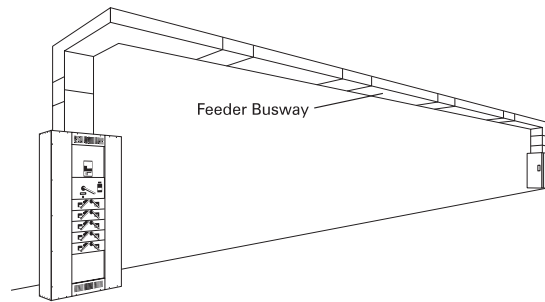

Filler Plates

Plates used to cover unused spaces in a panel.

Four-Quadrant Operation

Describes the operation of a variable speed drive that is capable of providing forward or reverse torque with the motor rotating in either the forward or reverse direction.

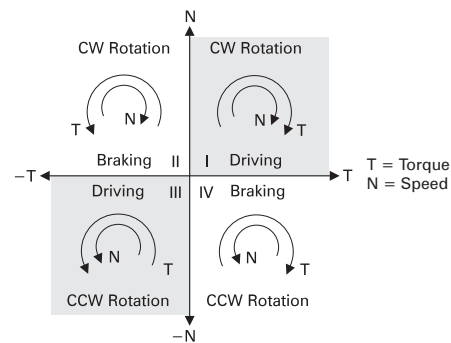

Frequency

The rate of variation of a periodic waveform. The symbol for frequency is "f." The unit for frequency is Hz.

Full-Voltage Starter

A type of motor starter often used for three-phase induction motors that applies the full-line voltage to the motor immediately. Sometimes called an across-the-line starter.

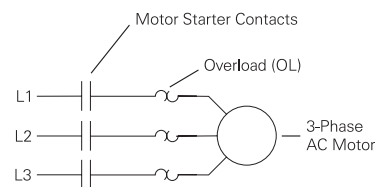

Fuse

A device designed to open a circuit when its rated current is exceeded. This is usually accomplished when a metal link in the fuse melts. Fuses are available in various sizes and types. Some have a time delay or more than one element.

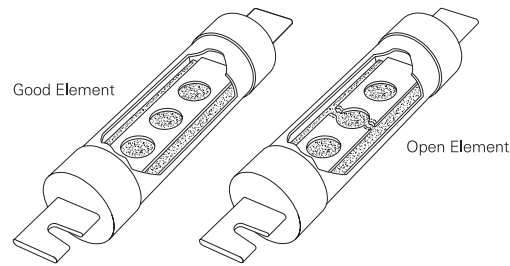

Fuse Class

A letter designation given to a fuse to identify its operating and construction characteristics.

Class	AIC Rating
H	10,000 A
K	50,000 A
R	200,000 A
J	200,000 A
L	200,000 A

Ground

A connection to the earth or to a conductive object such as an equipment chassis.

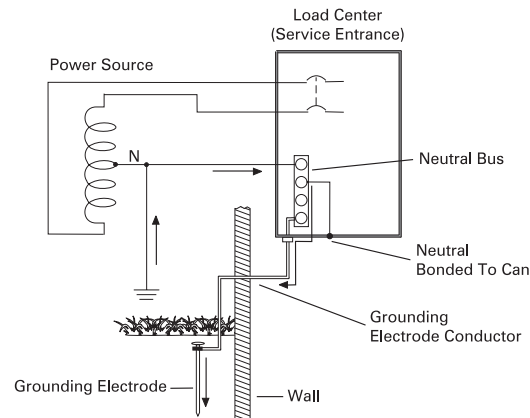

Ground Fault

A condition in which current unintentionally flows to ground.

Ground Fault Circuit Interrupter (GFCI)

A device designed to interrupt current in a circuit if the current in the hot wire is not equal to current in the neutral wire.

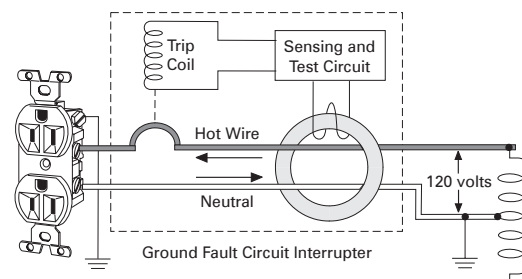

Harmonics

The base frequency of a power supply is said to be the fundamental frequency or first harmonic. Additional harmonics can appear on the power supply which are usually whole number multiples of the first harmonic. The 3rd harmonic of a 60 Hz power supply, for example, is 180 Hz (3 x 60).

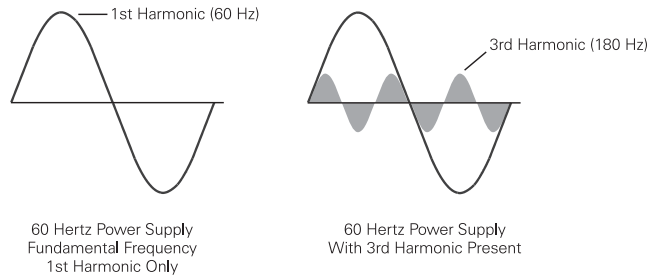

Harmonic Distortion

The effect of harmonics on the fundamental frequency. Harmonic distortion is destructive and interferes with the operation of electronic devices.

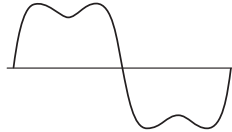

Henry

The basic unit of inductance. The symbol for the henry is "H."

Hertz

A unit of frequency equal to one cycle per second. Hertz is abbreviated Hz.

Hexadecimal

A number system that uses powers of 16.

Decimal	Binary	BCD	Hexadecimal
0	0	0000	0
1	1	0001	1
2	10	0010	2
3	11	0011	3
4	100	0100	4
5	101	0101	5
6	110	0110	6
7	111	0111	7
8	1000	1000	8
9	1001	1001	9
10	1010	0001 0000	A
11	1011	0001 0001	B
12	1100	0001 0010	C
13	1101	0001 0011	D
14	1110	0001 0100	E
15	1111	0001 0101	F
16	1 0000	0001 0110	10
17	1 0001	0001 0111	11
18	1 0010	0001 1000	12
19	1 0011	0001 1001	13
20	1 0100	0010 0000	14

Horsepower

A unit of power. Horsepower is symbolized by "HP". 1 horsepower is equal to 746 watts.

Impedance

The total opposition to alternating current. Impedance is the vector sum of resistance and reactance. The symbol for impedance is "Z." The unit for impedance is the ohm.

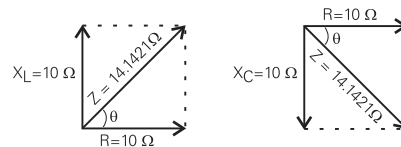

Inductance

The property of an electrical circuit that causes it to oppose changes in current. Inductance is designated by the symbol “L” and is measured in henries.

Inductive Proximity Sensor

A type of sensing switch that uses an electromagnetic coil to detect the presence of a metal object without coming into physical contact with it. Inductive proximity sensors ignore non-metallic objects.

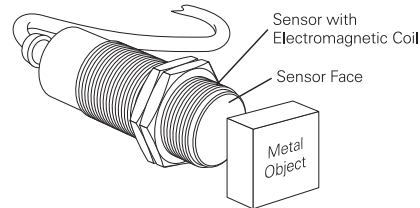

Inductive Reactance

The opposition to alternating current resulting from circuit inductance. Inductive reactance is directly proportional to frequency and inductance. The symbol for inductive reactance is “X_L.” The unit for inductive reactance is the ohm.

$$X_L = 2\pi f l$$

Inductor

A device manufactured to have a specific inductance. An inductor is made from a coil of wire and is sometimes called a coil or choke.

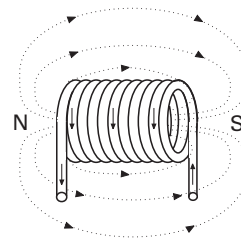

Input/Output (I/O) System

The part of a control system that interfaces to the real world. The I/O system accepts signals from switches and sensors, and provides signals to actuating devices, indicators, etc.

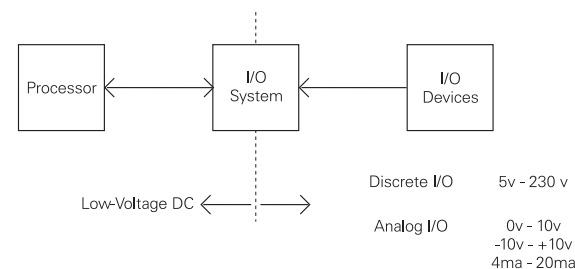

Institute of Electrical and Electronic Engineers (IEEE)

An organization open to individual membership that provides a variety of services for its members, but also develops numerous standards for electrical and electronic equipment and practices.

Instrument Transformer

A type of *transformer* used to allow circuits to sense the *voltage* or *current* of associated *conductors*. A potential transformer (PT) is used to step-down voltage. A current transformer (CT) is used to sense the level of current.

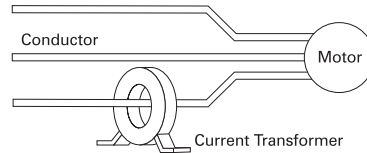

Insulated Case Circuit Breaker (ICCB)

A type of *circuit breaker* that combines the high *interrupting rating* of a *molded case circuit breaker* with the high short-time ratings of a *power circuit breaker*. Also called an encased systems breaker.

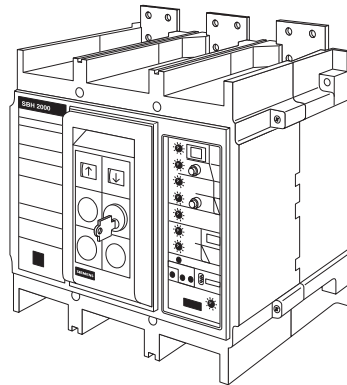

Insulated Gate Bipolar Transistor (IGBT)

A type of *transistor* often used as a switching device in the *inverter* section of a *variable frequency drive*. *Voltage* on the gate element is used to control the *current* flowing between the collector and emitter.

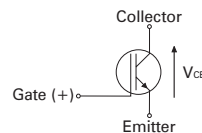

Insulation Class

Standards established by the *National Electrical Manufacturers Association (NEMA)* to meet *motor* temperature requirements found in different operating environments. The combination of an *ambient temperature* of 40°C and allowed temperature rise equals the maximum winding temperature of a *motor*. A margin is also allowed to provide for a point at the center of the *motor's* windings where the temperature is higher.

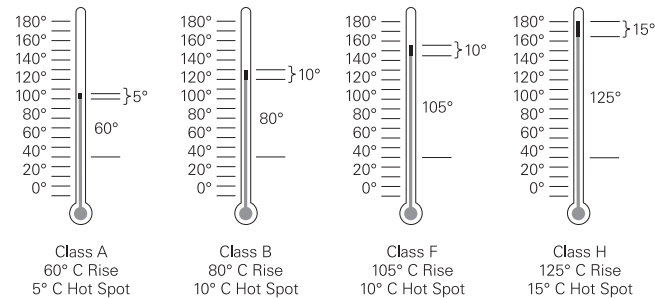

Insulator

A material with a high *resistance* to the flow of electrons. Plastic, rubber, glass, and mica are examples of materials that are good insulators.

International Electrotechnical Commission (IEC)

An organization based in Geneva, Switzerland, with over 50 member nations. IEC writes standards for electrical and electronic equipment and practices.

Interrupting Rating

The maximum level of fault *current* that a *circuit breaker* or *fuse* can interrupt. The interrupting rating is also called the ampere interrupting capacity (AIC).

Inverter

A device that converts *direct current* to *alternating current*. Inverter is also used as a synonym for an AC drive even though the AC drive usually includes other circuits.

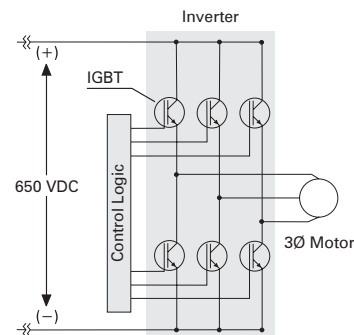

ISO

A federation of standards organizations from over 100 countries that develops voluntary standards for business, science, and technology. The official name is Organization Internationale de Normalisation. The name ISO is from the Greek word "isos" which means equal.

Isolation Transformer

A transformer used to limit the transfer of electrical noise from one circuit to another.

Joule

The basic unit of electrical energy. 1 Joule is equal to 1 watt-second or the amount of energy transferred in one second when the power is one watt.

Knockout

A place in an enclosure where a piece of the enclosure can be removed to allow for cabling.

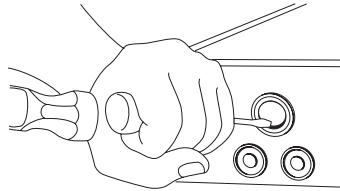

Ladder Logic

A method of programming a programmable logic controller that uses symbols that evolved from the diagrams used with control relays.

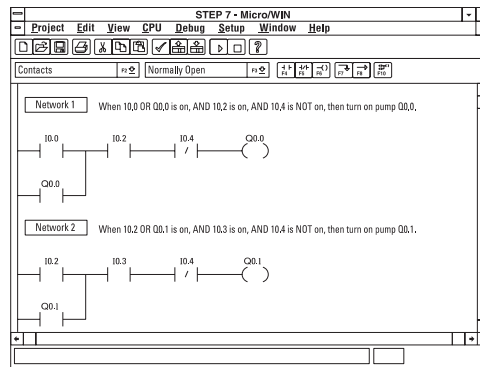

Limit Switch

A type of sensing switch that opens or closes its contacts when its actuator is moved by an object.

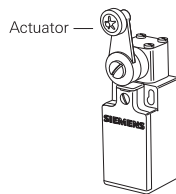

Limit Switch Positions

The following terms identify the operating positions of a *limit switch*.

Position	Definition
Free Position	Position of actuator when no external force is applied.
Pretravel	Distance or angle traveled moving the actuator from the free position to the operating position.
Operating Position	Contacts in the limit switch change from their normal state (NO or NC) to their operated state.
Overtravel	Distance the actuator can travel safely beyond the operating position.
Differential Travel	Distance traveled between the operating position and the release position.
Release Position	Contacts change from their operated state to their normal state.
Release Travel	Distance traveled from the release position to the free position.

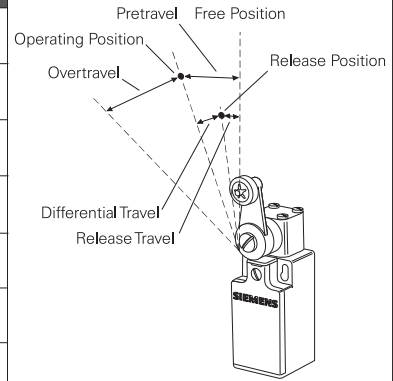

Load-Break Switch

A switch designed to safely interrupt load *current*.

Load Center

An industry term used to identify a lighting and appliance *panelboard* when it is used in certain (usually residential) applications.

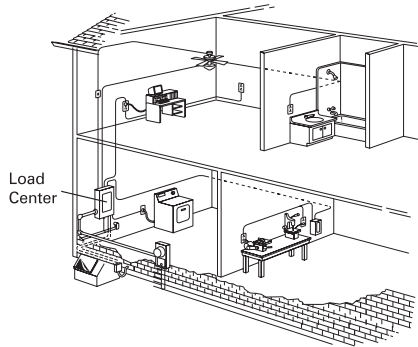

Local Area Network (LAN)

A communication system that interconnects intelligent devices within a limited area, but may also connect other networks for larger-scale communication.

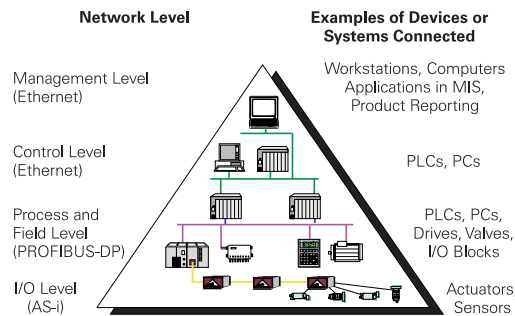

Main Breaker

The circuit breaker in a load center, panelboard, switchboard, or switchgear that is connected to the source of supply.

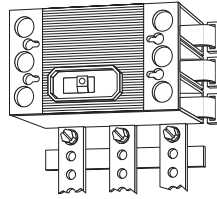

Main Lug Only

A designation given to a load center or panelboard to indicate that it does not include a main breaker.

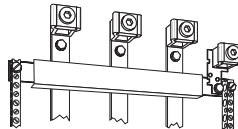

MCM

Thousands of circular mils. A method for designating the cross-sectional area of a conductor, especially conductors larger than AWG 4/0 (four aught). One mill is equal to 1/1000 of an inch. Circular mil area is the diameter (in mils) of a circular conductor squared. 1 MCM is 1000 circular mils (also shown as 1kcmil).

Metric Unit Prefix

A prefix added to a unit of measure to increase or decrease the size of that unit of measure. For example, the metric unit prefix kilo can be added to meter to form a unit of length (kilometer) equal to 1000 meters. Metric unit prefixes are associated with powers of ten.

Metric Prefix Examples

Value	Prefix	Symbol
1,000,000,000 = 10^9	giga	G
1,000,000 = 10^6	mega	M
1,000 = 10^3	kilo	k
0.001 = 10^{-3}	milli	m
0.000001 = 10^{-6}	micro	μ
0.000000001 = 10^{-9}	nano	n

Microprocessor

The integrated circuit or chip that contains the central processor unit.

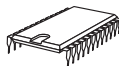

Molded Case Circuit Breaker

A *circuit breaker* enclosed in an insulated housing. The housing is normally made of molded plastic.

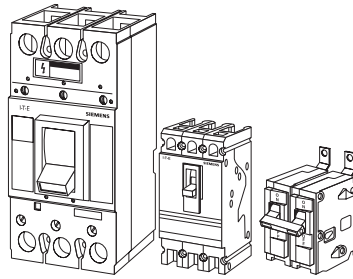

Molded Case Switch

A switch enclosed in an insulated housing similar to that of a *molded case circuit breaker*.

Motor

A device used to transform electrical energy into mechanical energy.

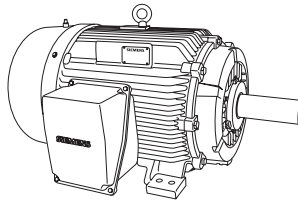

Motor Control Center

A metal *enclosure* containing multiple *motor* control circuits. Typically, individual control circuits are mounted in removable containers often referred to as pans or buckets.

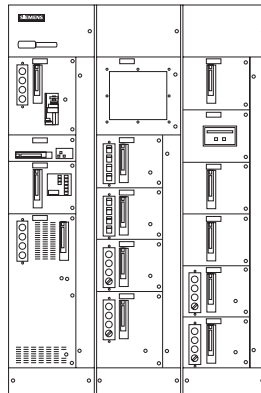

Motor Insulation Class

A letter designation based upon standards established by the National Electrical Manufacturers Association that corresponds to a motor's allowable temperature rise and maximum allowable operating temperature (based on 40°C ambient temperature).

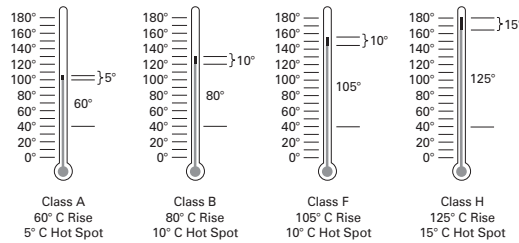

Motor Starter

Often refers to a contactor and an overload relay assembled together to remotely control the operation of a motor while providing overload protection. This definition applies to a full voltage starter.

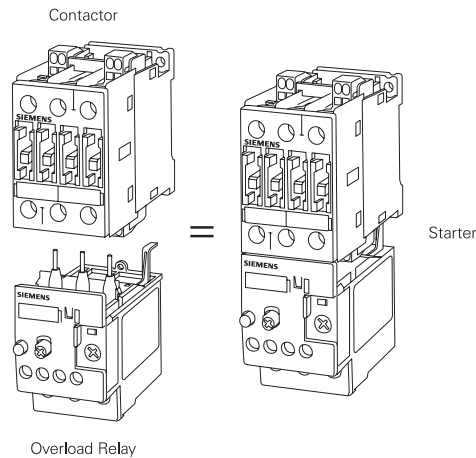

Mutual Induction

A process that involves varying lines of magnetic flux from one conductor that induce a voltage into a second adjacent conductor. This is the basic operating principle of a transformer.

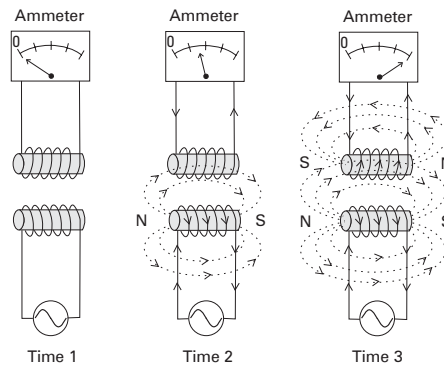

National Electrical Manufacturers Association (NEMA)

An organization of manufacturers of electrical equipment that, among other things, develops standards for electrical equipment.



National Electrical Code® (NEC®)

A document revised every three years based upon inputs to and recommendations of the National Electrical Code Committee of the *National Fire Protection Association*. The intent of the *NEC®* is to describe safe electrical practices. Although the *NEC®* is an advisory document, its use is often incorporated into laws and regulatory practices.

National Fire Protection Association (NFPA)

A private, nonprofit organization with international membership. The NFPA has been the sponsor of the *National Electrical Code® (NEC®)* since 1911.

NEMA Enclosure Type

A designation given to an *enclosure* based on standards published by the *National Electrical Manufacturers Association*. The NEMA type provides an indication of degree of protection provided by the enclosure.

NEMA Enclosure Type Examples

NEMA Type	Description
1	Intended for indoor use. Provides protection against a limited amount of falling dirt.
3R	Intended for outdoor use. Provides protection against rain, sleet, and damage from external ice formation.
4	Intended for indoor or outdoor use. Provides protection against windblown dust and rain, splashing water, hose-directed water, and damage from external ice formation.
4X	Intended for indoor and outdoor use. Provides protection against corrosion, windblown dust and rain, splashing water, hose-directed water, and damage from external ice formation.
12	Intended for indoor use. Provides protection against circulating dust, falling dirt, and dripping noncorrosive liquids.

NEMA Frame Size

A designation that identifies motor dimensions based upon standards provided by the National Electrical Manufacturers Association. Motors too large to correspond to NEMA frame sizes are referred to as above NEMA motors.

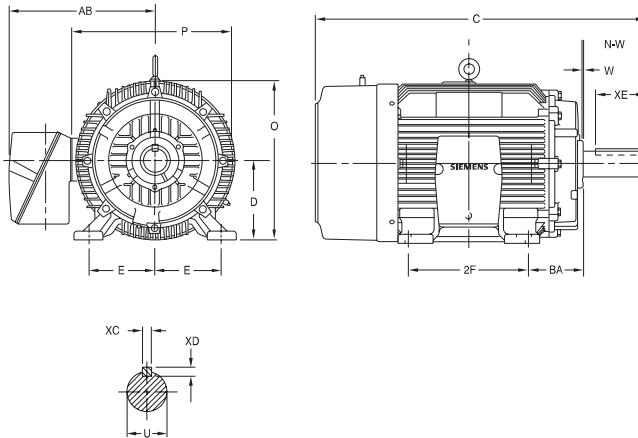

NEMA Motor Design

A letter designation based upon standards established by the National Electrical Manufacturers Association that corresponds to a motor's speed and *torque* characteristics.

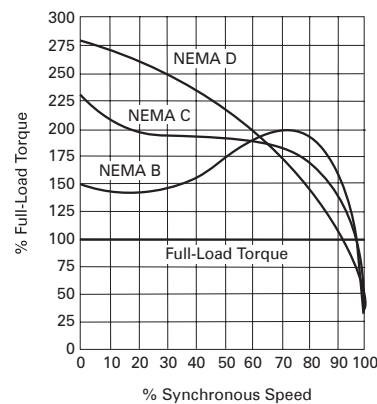

Neutral

A reference connection in a power distribution system.

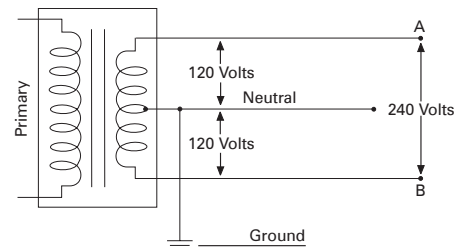

Ohm

The basic unit of resistance, reactance and impedance. The symbol for the ohm is " Ω ," the Greek letter omega.

Ohmmeter

A meter designed to measure resistance.

Ohm's Law

A law that states that the current in a circuit is directly proportional to the voltage and inversely proportional to the resistance.

$$I = \frac{E}{R}$$

Open Drip Proof (ODP)

A motor enclosure type that permits air flow through the motor, but is designed to prevent liquids or solids falling from above at angles up to 15 degrees from the vertical from entering the motor.

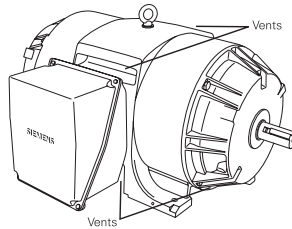

Open-Loop Control

A control technique that does not use a feedback signal.

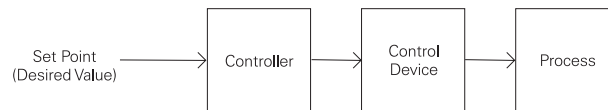

Overcurrent

A current in excess of the rated current for a device or conductor. An overcurrent can result from an overload, short circuit, or ground fault.

Overload

Can refer to an operating condition in excess of a full-load rating or a current high enough to cause damage if it is present long enough. An overload does not refer to a short circuit or ground fault.

Overload Relay

A device used to protect a motor from damage resulting from an overcurrent.

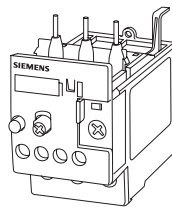

Overload Relay Class

Defines the length of time an overcurrent condition can exist before an overload relay trips. For example, a class 10 overload relay will allow 600% of full load amperes for up to 10 seconds.

Pad-Mounted Transformer

An enclosed transformer mounted outside on a concrete pad.

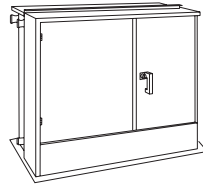

Panelboard

A front-accessible panel containing overcurrent protection devices for use in controlling lighting, heating, or power circuits.

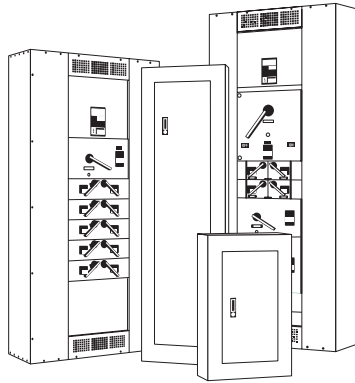

Photoelectric Sensor

A type of sensing switch that uses light to detect the presence of an object without coming into physical contact with the object.

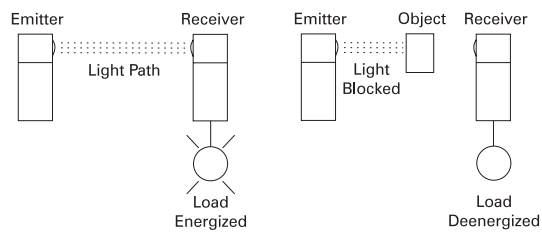

Pilot Light

A small light used to indicate a specific condition in a circuit.

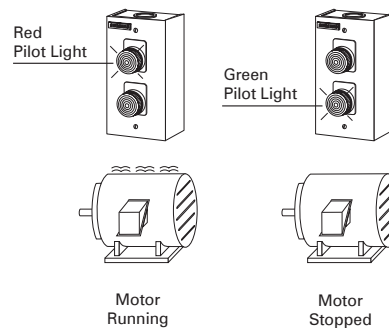

PLC Scan

A complete execution cycle of a programmable logic controller. The PLC scan involves taking in new inputs, executing the user program, performing diagnostic and communication functions, and generating new outputs. The PLC scan is repetitively executed.

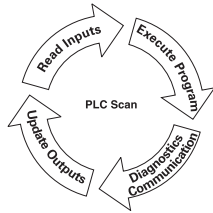

Plug-in Busway

Busway that incorporates plug-in units to allow loads to be distributed over the length of the run.

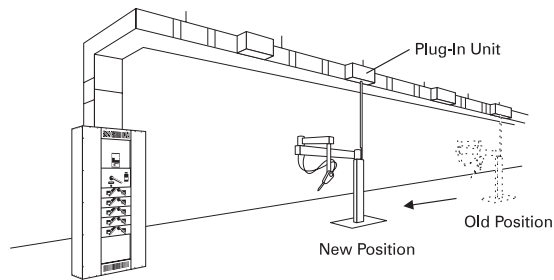

Potentiometer

A type of variable resistor. Often referred to as a pot.

Power

The rate at which work is done or energy is transformed. In an electric circuit, power is measured in watts or sometimes in horsepower. The term power is also often used loosely to refer to electrical energy.

Power Circuit Breaker

A circuit breaker, characterized by large frame sizes and high short time ratings, which is used in switchgear or switchboards, and whose open construction allows for easy inspection, maintenance, and replacement of current carrying and operating parts. Available for low and medium voltage systems.

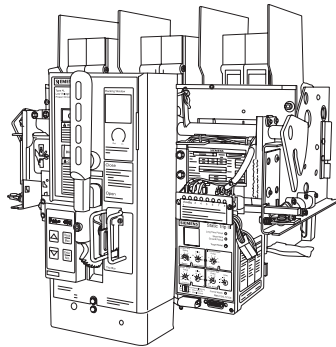

Power Factor

The ratio of *true power* to *apparent power* in a circuit. Power factor is also equal to the cosine of the phase angle.

Pressure Switch

A control device that opens or closes its contacts in response to a change in the pressure of a liquid or gas.

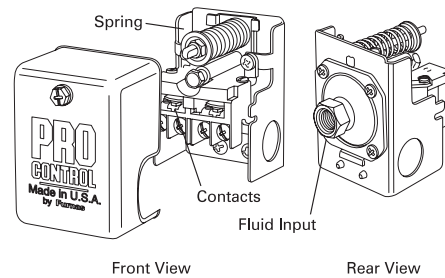

Programmable Logic Controller (PLC)

A type of industrial computer used to control machines and processes. The PLC accepts inputs from switches and sensors and uses these inputs together with other data and program logic to control output devices.

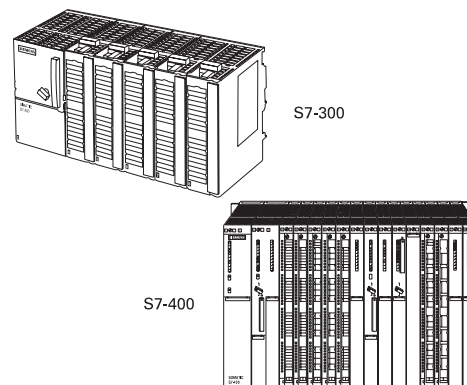

Proportional-Integral-Derivative (PID) Control

A *closed-loop control* technique that seeks to minimize error by reacting to three values. One that is proportional to the error, one that is representative of the error over time, and one that is representative of the rate of change of the error.

Proximity Sensor

A type of *sensing switch* that detects the presence or absence of an object without physical contact.

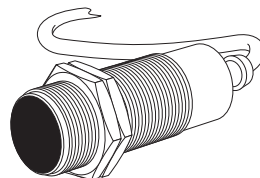

Pulse Width Modulation (PWM)

As applied to *variable frequency drives*, this is a technique for controlling the voltage applied to an AC motor by varying the pulse width while also controlling the frequency of the pulses.

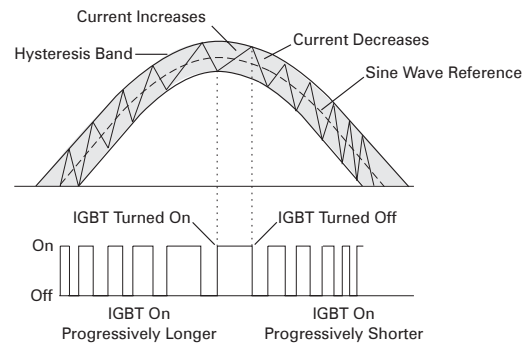

Pushbutton

A control device used to manually open and close a set of contacts.

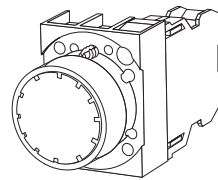

Random Access Memory (RAM)

Usually refers to a type of *semiconductor* memory often used for temporary storage because it requires the continual application of power to retain information. For some systems, battery backup is used to prevent data or program loss in the event of a power outage.

Reactance

The opposition to *alternating current* resulting from circuit *inductance* and *capacitance*. The symbol for reactance is "X." The unit for reactance is the ohm.

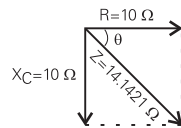

Reactive Power

Power associated with *inductance* or *capacitance*. The unit for reactive power is the var.

Read Only Memory (ROM)

Usually refers to a type of *semiconductor* memory often used for permanent storage of data or programs that do not change.

Rectifier

A device or circuit that converts alternating current to direct current.

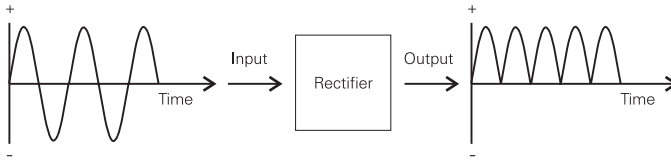

Reduced-Voltage Controller

A type of motor starter that applies less than the full-line voltage to a three-phase induction motor while it is starting. A variety of types of reduced-voltage controllers exist including solid-state starters.

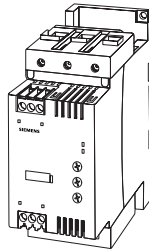

Resistance

A property of a material or circuit to oppose current flow. Resistance is symbolized by "R" and is measured in ohms.

Resistance Temperature Detector (RTD)

A device used to sense temperature that varies in resistance as temperature changes.

Resistor

A device manufactured to have a specific amount of resistance.

$$R = \rho \frac{l}{A}$$

— Length
— Cross-Section Area
— Resistivity of Material

Resolver

An angular position sensing device that utilizes a rotating transformer with two secondary windings arranged at right angles to each other to provide angular position information. The amplitude of the wave induced into each stator winding depends on the angular position of the rotor winding. Since the amplitude variations available at the stator windings are 90° apart, one is called a sine signal and the other is called a cosine signal.

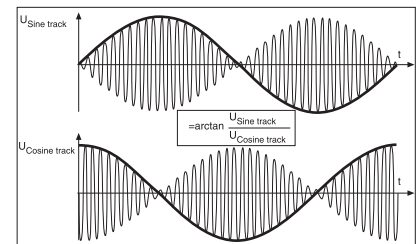
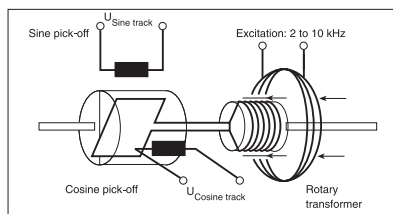

Root-mean-square or RMS Value

The effective value of a current or voltage. Root-mean-square is descriptive of the mathematical process used to calculate the effective value of a periodic current or voltage.

Rotor

The rotating elements of the magnetic circuit of a rotating machine such as a motor.



Safety Switch

A switch mounted in an enclosure. Fusible enclosed switches include provisions for fuses in the enclosure.

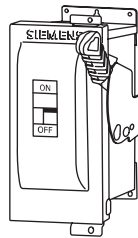

Secondary Unit Substation

A coordinated design consisting of one or more transformers mechanically and electrically linked to switchgear or switchboard assemblies with an outgoing voltage rated below 1000 volts.

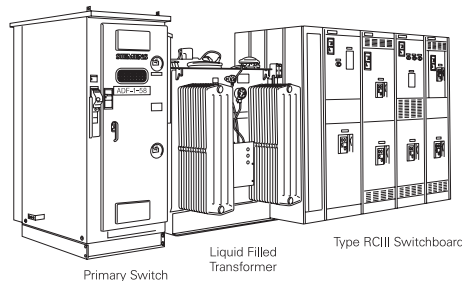

Selective Coordination

Applying circuit breakers in a manner that will minimize the extent of an outage in the event of a fault. Circuit breakers are typically installed in a branching arrangement. In the event of a fault, the breaker electrically closest to the fault should trip first. This can be accomplished by properly sizing and adjusting all breakers.

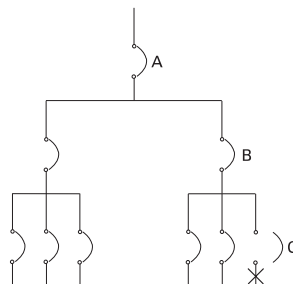

Selector Switch

A control device with two or more positions used to manually open and close contacts.

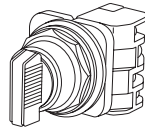

Semiconductor

A special type of material with more *resistance* than a *conductor*, but less than that of an *insulator*. Semiconductors can be manufactured to produce devices such as *diodes*, *transistors*, *thyristors*, etc.

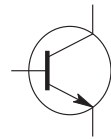

Transistor



Diode

Sensing Switch

A device, often called a sensor, used to provide information on the presence or absence of an object. Examples include a *limit switch*, *photoelectric sensor*, *inductive proximity sensor*, *capacitive proximity sensor*, and *ultrasonic proximity sensor*.

Sensor	Advantages	Disadvantages	Applications
Limit Switch	<ul style="list-style-type: none"> • High Current Capability • Low Cost • Familiar "Low-Tech" Sensing 	<ul style="list-style-type: none"> • Requires Physical Contact with Target • Very Slow Response • Contact Bounce 	<ul style="list-style-type: none"> • Interlocking • Basic End-of-Travel Sensing
Photoelectric	<ul style="list-style-type: none"> • Senses all Kinds of Materials • Long Life • Largest Sensing Range • Very Fast Response Time 	<ul style="list-style-type: none"> • Lens Subject to Contamination • Sensing Range Affected by Color and Reflectivity of Target 	<ul style="list-style-type: none"> • Packaging • Material Handling • Parts Detection
Inductive	<ul style="list-style-type: none"> • Resistant to Harsh Environments • Very Predictable • Long Life • Easy to Install 	<ul style="list-style-type: none"> • Distance Limitations 	<ul style="list-style-type: none"> • Industrial and Machines • Machine Tool • Senses Metal-Only Targets
Capacitive	<ul style="list-style-type: none"> • Detects Through Some Containers • Can Detect Non-Metallic Targets 	<ul style="list-style-type: none"> • Very Sensitive to Extreme Environmental Changes 	<ul style="list-style-type: none"> • Level Sensing
Ultrasonic	<ul style="list-style-type: none"> • Senses all Materials 	<ul style="list-style-type: none"> • Resolution • Repeatability • Sensitive to Temperature Changes 	<ul style="list-style-type: none"> • Anti-Collision • Doors • Web Brake • Level Control

Serial Communication

Intelligent devices, such as computers, communicate with each other by sending bits of data in a series of *binary* signals to each other. RS-232 and RS-485 are specifications commonly used in serial communication.

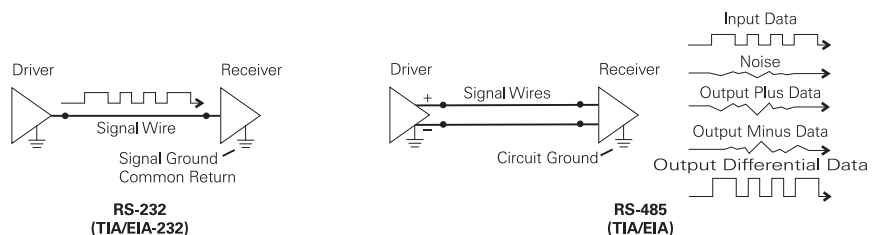

Service Entrance

The place where power is brought into a building. Also used to describe equipment at the service entrance.

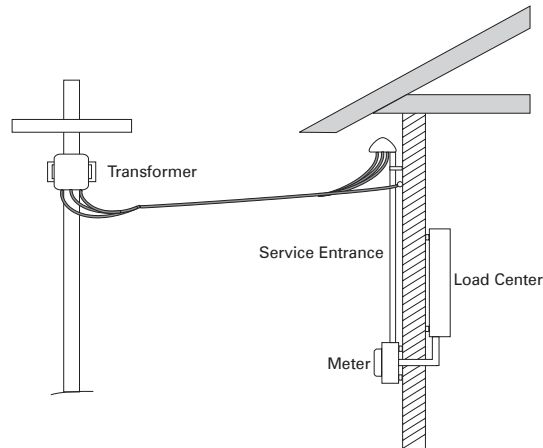

Service Factor

A numerical value that is multiplied by a motor's rated horsepower to determine the maximum horsepower at which the motor should be operated.

Service Head

A device used to connect busway at the service entrance.

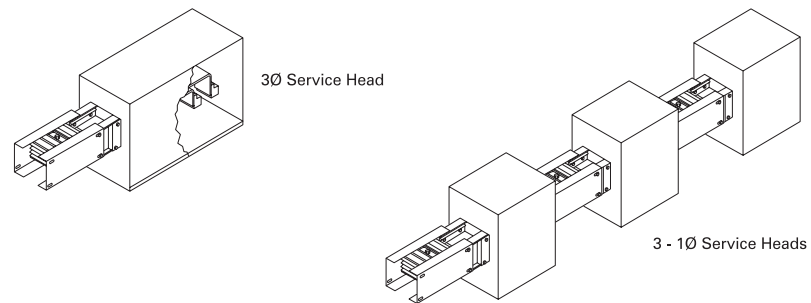

Service Section

The switchboard section connected to incoming power.

Servo Drive

Usually refers to an electronic device used to control the speed and torque of a servo motor as part of a closed-loop positioning control system.

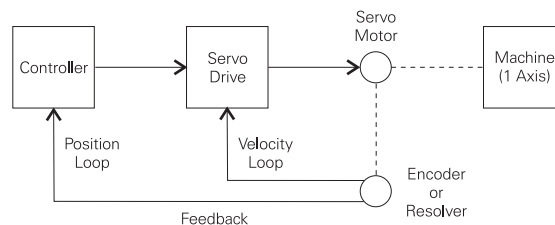

Servo Motor

A motor designed with the dynamic response required for closed-loop positioning applications.

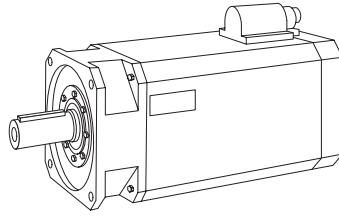

Set Point

The value used by a control circuit as desired value of a process variable.

Short Circuit

A normally unintended low resistance path for current.

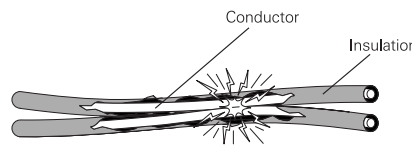

Shunt Trip

A device used to remotely trip a circuit breaker.

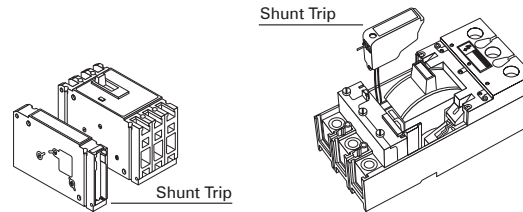

Single Quadrant Operation

Describes the operation of a variable speed drive that can provide torque to drive the motor, but cannot provide braking torque.

Slip

In a three-phase induction motor, slip is the difference between the synchronous speed and the rotor speed and is often expressed as a percentage.

$$\% \text{ Slip} = \frac{N_s - N_R}{N_s} \times 100$$

Solid-State

Used to describe equipment that contains semiconductor devices in an electronic circuit.

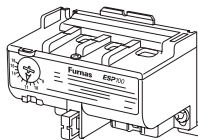

Speed-Torque Curve

A graphical representation of the torque provided by a motor over a range of speeds.

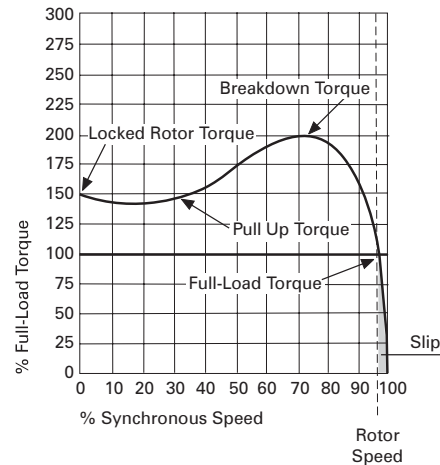

Splice Plates, Splice Bars

Plates used to join the horizontal bus bars of adjoining switchboard or motor control center sections.

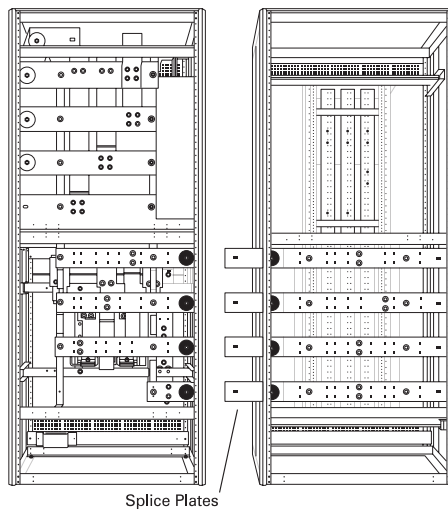

Starter Ratings

Motor Starters are rated according to size and type of load. NEMA and IEC rate motor starters differently. IEC-rated devices are rated according to maximum operational current. NEMA specifies sizes from size 00 to size 9.

Size of Controller	Horsepower at 460 V/60 Hz
00	2
0	5
1	10
2	25
3	50
4	100
5	200
6	400
7	600
8	900
9	1600

Stator

The stationary elements of the magnetic circuit of a rotating machine such as a motor.

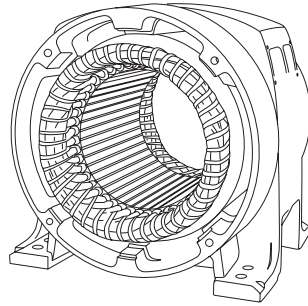

Step-down Transformer

A *transformer* with more turns of wire in its primary coil than in its secondary coil. The step-down transformer is used to step down the primary *voltage* to a lower secondary voltage.

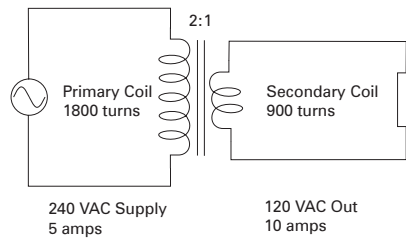

Step-up Transformer

A *transformer* with fewer turns of wire in its primary coil than in its secondary coil. The step-up transformer is used to step up the primary *voltage* to a higher secondary voltage.

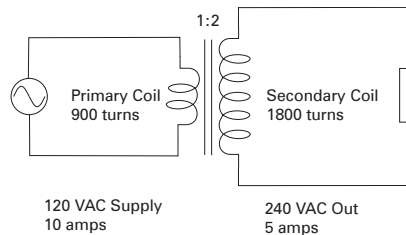

Surge

A transient increase in *current* and *voltage*.

Surge Protection

Used to describe equipment designed to prevent or limit damage resulting from a *surge*, provided that the surge does not exceed the capabilities of the protection devices.

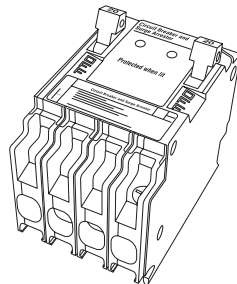

Switchboard

A large panel or assembly of panels containing switches, overcurrent protective devices, buses, and associated instruments.



Switchgear

A coordinated design consisting of switching and interrupting devices and associated equipment such as control and protective devices and metering.

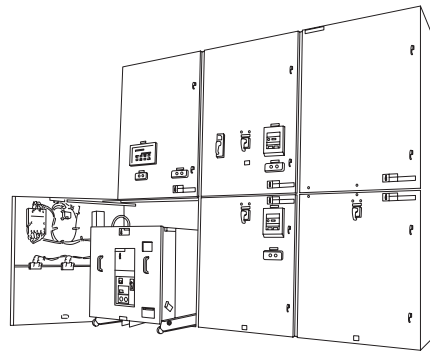

Synchronous Speed

The speed of the rotating magnetic field in a three-phase motor. Synchronous speed is determined by the line frequency and the number of motor poles.

$$N_s = \frac{120f}{P}$$

Frequency
No. of Poles
Synchronous Speed

Tachometer

A device used to provide a feedback signal representative of the speed of a rotating machine. Some tachometers are analog devices. Others provide a digital signal.

Thermal-Magnetic

Used to describe a device that uses both heat and magnetism as part of its operating principles. For example, a thermal-magnetic *circuit breaker* can be tripped either by heat or magnetic force resulting from excessive *current*.

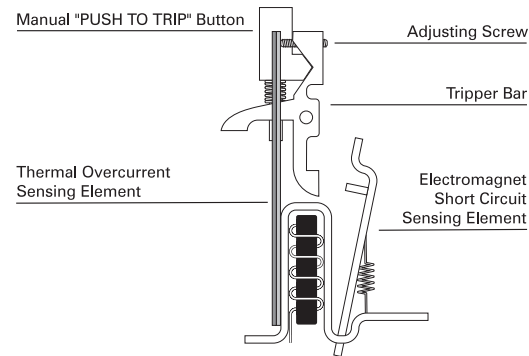

Thermistor

A device used to sense temperature that varies in *resistance* as temperature changes.

Thermocouple

A device composed of two types of metal that produces a small *voltage* representative of the temperature at some point in a process.

Thyristor

A family of multi-layer *semiconductor* devices that includes silicon controlled rectifiers (SCR), triacs, and gate turnoff (GTO) thyristors. Thyristors are often used in *rectifier* or *power* switching circuits.

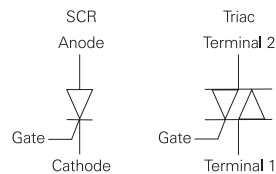

Time-Current Curve

A graph showing how long before a circuit breaker will trip at each level of fault current.

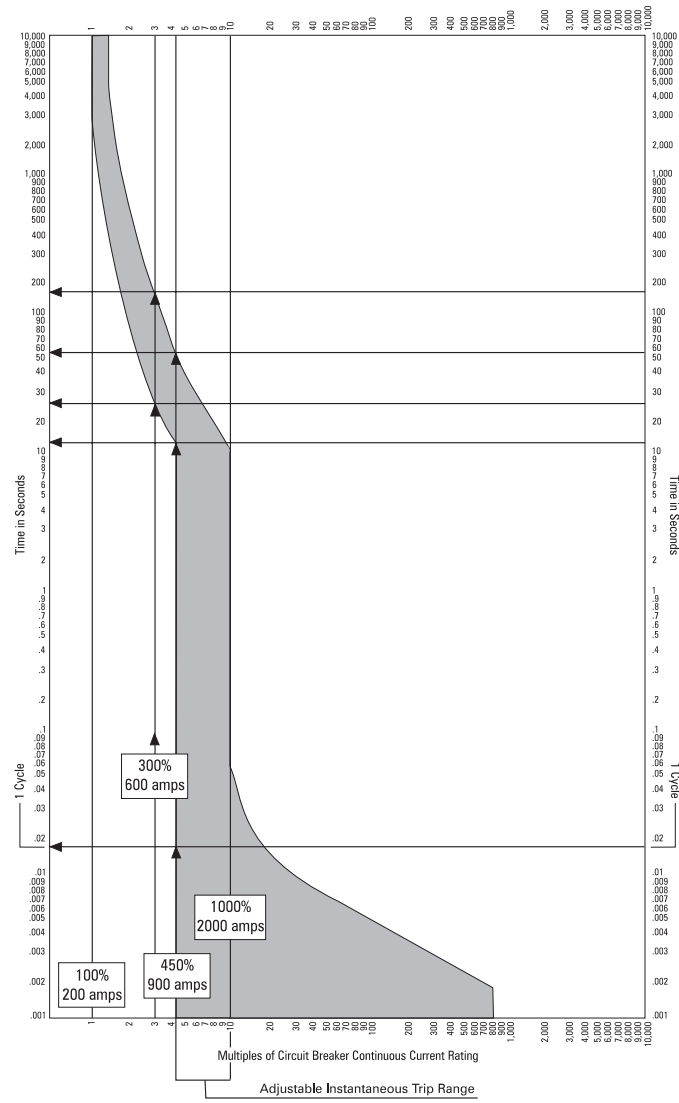

Timing Relay

A control device that opens or closes its contacts after a time delay. Some timing relays begin the time delay when the relay is energized. Others begin the time delay when the relay is de-energized.

Torque

A turning or twisting force. Since torque is expressed as a force times the length of the radius at which the force is measured, torque is represented in compound units such as pound-feet (lb.-ft.)

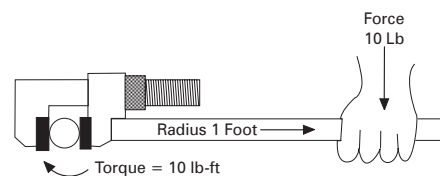

Total Harmonic Distortion (THD)

The ratio of *harmonic distortion* to the fundamental *frequency*. The greater the THD the more distortion there is.

$$\% \text{ of THD} = \frac{\text{RMS of Total Harmonic Distortion Signal}}{\text{RMS of Fundamental Frequency}} \times 100$$

Totally Enclosed Fan Cooled (TEFC)

A motor *enclosure* type that restricts the flow of air into or out of the motor, but uses a fan to blow air over the motor's exterior.

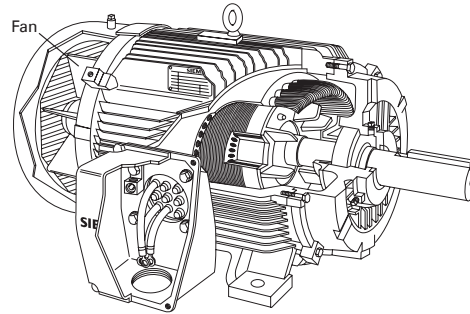

Totally Enclosed Non-ventilated (TENV)

A motor *enclosure* type that restricts the flow of air into or out of the motor.

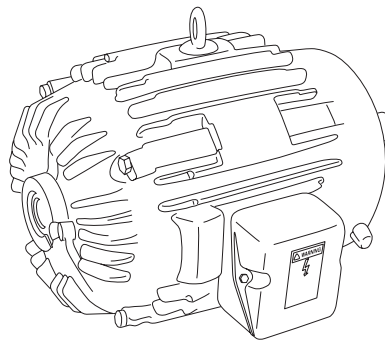

Totally Integrated Automation (TIA)

A strategy developed by Siemens that emphasizes the seamless integration of automation products.

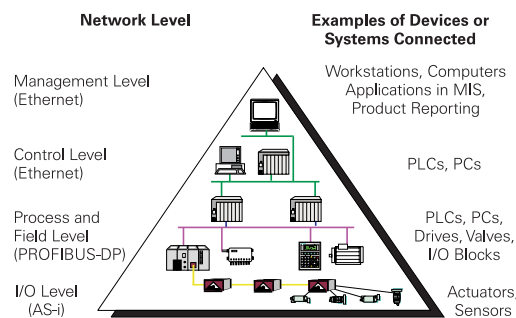

Transducer

A device that converts energy from one form to another. Often refers to sensing devices used to monitor or control a process.

Transformer

Coils of wire wound on a common frame that allow electrical energy to be transferred from one circuit to another.

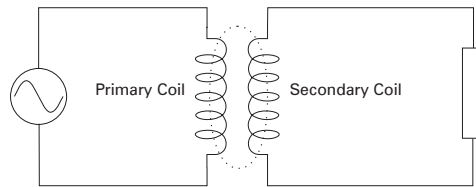

Transistor

A *semiconductor* device which usually has three terminals although the names of the terminals are different for different types of transistors. Some types of transistors are used as electronic switches.

Trim

The front cover of a panel, often including an access door.

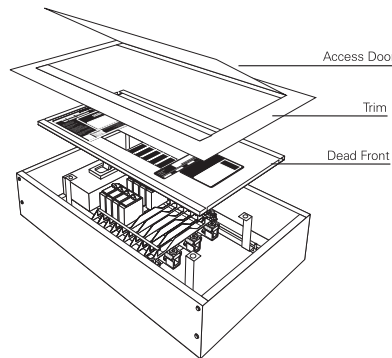

Trip Unit

The part of the *circuit breaker* that can be manually or electronically set to determine under what conditions its contacts will automatically open.

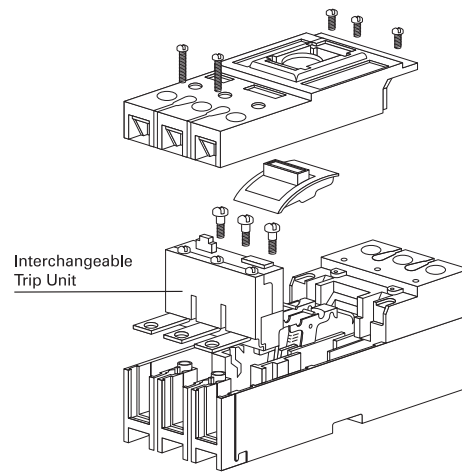

True Power

Also called real power, true power is power dissipated by circuit resistance. True power is equal to I^2R and is measured in watts. True power is also equal to the apparent power multiplied by the power factor.

Ultrasonic Sensor

A type of sensing switch that uses high frequency sound to detect the presence of an object without coming into contact with the object.

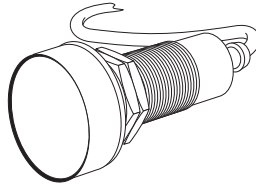

Underwriter's Laboratory (UL)

A private company that is nationally recognized as an independent testing laboratory. UL tests products for safety. Products that pass UL tests can carry a UL label. UL has several categories of labels based upon the type of product tested.

Unit Substation

A coordinated design consisting of one or more transformers mechanically and electrically linked to switchgear or switchboard assemblies.

Var

The basic unit for reactive power. Shortened from volt-ampere reactive.

Variable Frequency Drive (VFD)

An electronic device used to control the speed and torque of an AC motor. Also called an AC drive.

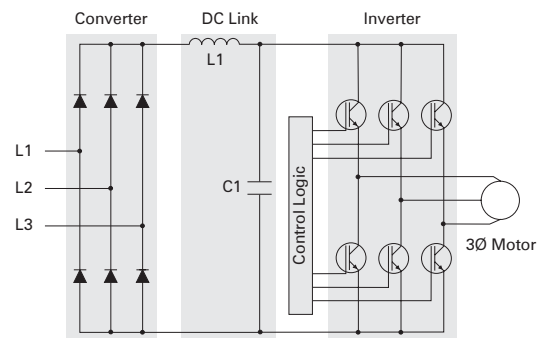

Variable Speed Drive

An electronic drive device to control the speed and *torque* of either an AC or DC motor. Also called an adjustable speed drive.

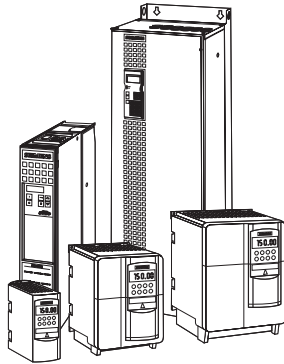

Vector Control

Describes a technique employed by some *variable frequency drives* that uses a complex mathematical model of a motor to provide excellent control of speed and *torque*.

Volt

The basic unit of *voltage*. The symbol for volt is "V."

Voltage

Also called difference of potential, *electromotive force*, or emf. Voltage is a force that when applied to a *conductor* causes *current* to flow. Voltage is symbolized by "E" or "V" and is measured in *volts*.

Voltmeter

A meter designed to measure *voltage*.

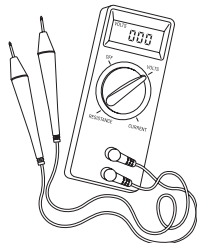

Volts per Hertz (V/Hz) Operation

Describes the operation of many *variable frequency drives* that control the speed of an AC motor by varying the *frequency* of the *voltage* applied to the motor while attempting to maintain a voltage to frequency ratio.

Watt

The basic unit of electric *power*. The symbol for watt is "W."

Watt-Hour Meter

A meter designed to measure electrical energy usage.

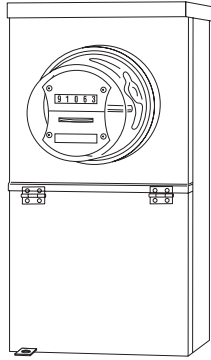

Word

Usually one or more bytes used to represent instructions or data in digital equipment.

Wye

A connection arrangement used for the primary and/or secondary of a three-phase transformer.

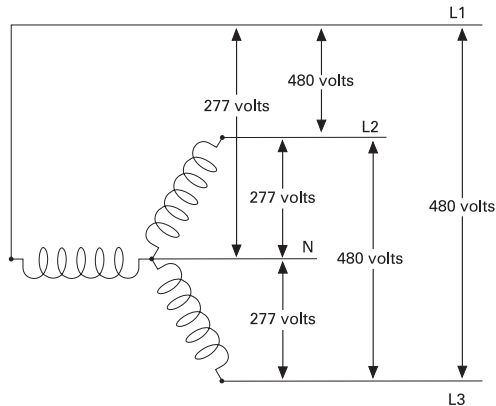

Review Answers

Review 1

1) generator; 2) step-up; 3) 120; 4) 120; 5) Lateral service; 6) six;
7) surge arrester; 8) GFCI.

Review 2

1) C; 2) TPS; 3) distribution; 4) SMM; 5) 4000.

Review 3

1) low; 2) 16.5; 3) SR; 4) transformer; 5) Feeder.

Review 4

1) b; 2) c; 3) 24; 4) SINUMERIK®.

Review 5

1) Reduced voltage; 2) drive; 3) PROFIBUS; 4) ASI; 5) batch;
6) Closed-loop.

Final Exam

The final exam is intended to be a learning tool. The book may be used during the exam. A tear-out answer sheet is provided. After completing the test, mail the answer sheet in for grading. A grade of 70% or better is passing. Upon successful completion of the test a certificate will be issued.

Questions

1. The most efficient way to transmit energy from a power company to the utility's customer via transmission lines is to _____.
 - a. Increase voltage and current
 - b. Increase voltage and reduce current
 - c. Decrease voltage and increase current
 - d. Decrease voltage and current

2. The *National Electrical Code*® requires _____ for all branch circuits that supply 125-volt, single-phase, 15- and 20-amp receptacle outlets installed in dwelling unit bedrooms.
 - a. Arc Fault Circuit Interrupters
 - b. Circuit Breaker/Surge Arresters
 - c. Ground Fault Circuit Interrupters
 - d. TPS

3. _____ is a motor starter manufactured by Siemens.
 - a. TIASTAR
 - b. S7-200
 - c. INNOVA PLUS™
 - d. SINUMERIK®

4. According to the *National Electrical Code*® (*NEC*®), _____ may be accessible from the rear as well as the front.
 - a. load centers
 - b. panelboards
 - c. switchboards
 - d. all of the above

12. _____ is an alternative approach to distributed control systems (DCS) used for process control.
- a. SIMATIC® PCS 7
 - b. Closed-loop control
 - c. WinCC®
 - d. PROFIBUS SMS
13. _____ refers to any device that acts as a link between the operator and the machine.
- a. SMM
 - b. AWG
 - c. MMS
 - d. HMI
14. _____ is the trade name for a Siemens motor control center.
- a. NXAIR P
 - b. SIRIUS
 - c. SIMATIC® HMI
 - d. TIASTAR
15. Medium voltage equipment is rated _____ .
- a. for 480 volts
 - b. for 1000 volts or less
 - c. greater than 1000 to 100,000 volts
 - d. greater than 100,000 to 230,000 volts
16. Which of the following is an HMI product?
- a. AC motor
 - b. WinCC®
 - c. Switchboard
 - d. Motor starter
17. _____ is a control technique that compares a feedback signal representative of an actual value with a desired value and responds to minimize the error.
- a. Open-loop control
 - b. Closed-loop control
 - c. Discrete control
 - d. Continuous control

18. Standards that correspond to a motor's speed and torque characteristics are published by ____.
- a. NEMA
 - b. UL
 - c. ISA
 - d. NEC®
19. The ____ publishes the *National Electrical Code*®.
- a. National Electrical Manufacturers Association
 - b. Underwriter Laboratories, Inc.
 - c. National Fire Protection Association
 - d. Institute of Electrical and Electronic Engineers
20. ____ is the trade name of one type of medium voltage switchgear manufactured by Siemens that features an "arc vented" design.
- a. RCIII
 - b. 5 - 15 kV
 - c. 38 KV
 - d. NXAIR P

NEC® and *National Electrical Code*® are registered trademarks of the National Fire Protection Association.

Notes

quickSTEP Online Courses

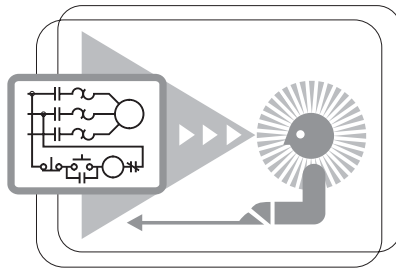

quickSTEP online courses are available at <http://www.sea.siemens.com/step>.

The quickSTEP training site is divided into three sections: Courses, Downloads, and a Glossary. Online courses include reviews, a final exam, the ability to print a certificate of completion, and the opportunity to register in the Sales & Distributor training database to maintain a record of your accomplishments.

From this site the complete text of all STEP 2000 courses can be downloaded in PDF format. These files contain the most recent changes and updates to the STEP 2000 courses.

A unique feature of the quickSTEP site is our pictorial glossary. The pictorial glossary can be accessed from anywhere within a quickSTEP course. This enables the student to look up an unfamiliar word without leaving the current work area.

