

SIEMENS

STEP 2000

AC Motors

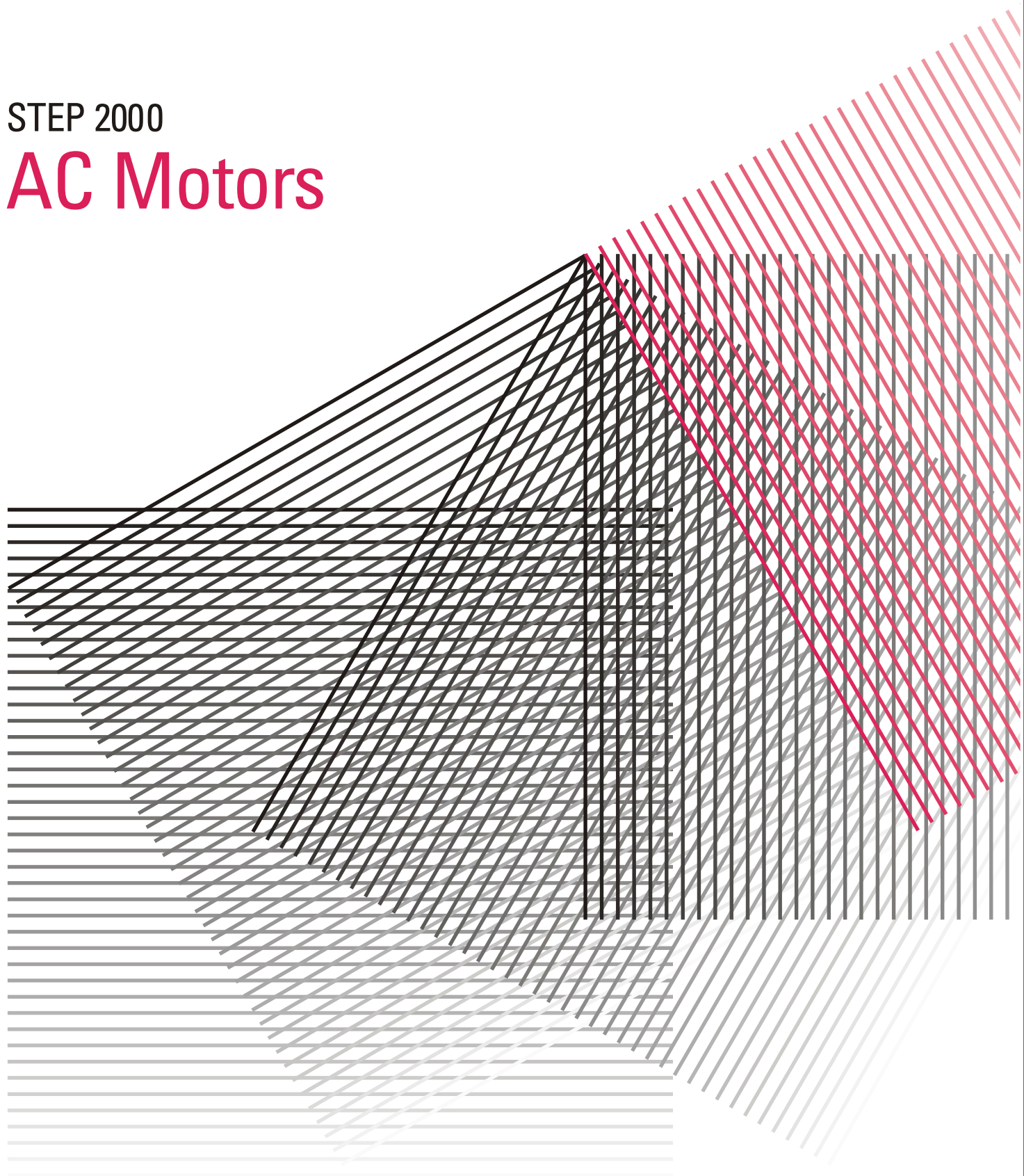

Table of Contents

Introduction	2
AC Motors	4
Force and Motion	6
AC Motor Construction	14
Magnetism	20
Electromagnetism	22
Developing a Rotating Magnetic Field	28
Rotor Rotation.....	34
Motor Specifications.....	39
NEMA Motor Characteristics.....	43
Derating Factors	51
AC Motors and AC Drives.....	53
Matching AC Motors to the Load	58
Enclosures	63
Mounting	67
Siemens Motors	74
Above NEMA Motors	79
Review Answers.....	84
Final Exam	85

Introduction

Welcome to another course in the STEP 2000 series, **Siemens Technical Education Program**, designed to prepare our distributors to sell Siemens Energy & Automation products more effectively. This course covers **AC Motors** and related products.

Upon completion of **AC Motors** you should be able to:

- Explain the concepts of force, inertia, speed, and torque
- Explain the difference between work and power
- Describe the construction of a squirrel cage AC motor
- Describe the operation of a rotating magnetic field
- Calculate synchronous speed, slip, and rotor speed
- Plot starting torque, accelerating torque, breakdown torque, and full-load torque on a NEMA torque curve
- Apply derating factors as required by an application
- Describe the relationship between V/Hz, torque, and horsepower
- Match an AC motor to an application and its load
- Identify NEMA enclosures and mounting configurations
- Describe Siemens Medallion™, PE-21 Plus™, vertical pump, and IEC motors
- Describe torque characteristics and enclosures of Siemens above NEMA motors

This knowledge will help you better understand customer applications. In addition, you will be better able to describe products to customers and determine important differences between products. You should complete **Basics of Electricity** before attempting **AC Motors**. An understanding of many of the concepts covered in **Basics of Electricity** is required for **AC Motors**. You may also want to complete **Basics of Control Components** which discusses the application of control devices for start, stop, and thermal protection of AC motors.

If you are an employee of a Siemens Energy & Automation authorized distributor, fill out the final exam tear-out card and mail in the card. We will mail you a certificate of completion if you score a passing grade. Good luck with your efforts.

Medallion and PE-21 Plus are trademarks of Siemens Energy & Automation, Inc.

National Electrical Code[®] and NEC[®] are registered trademarks of the National Fire Protection Association, Quincy, MA 02269. Portions of the National Electrical Code are reprinted with permission from NFPA 70-2002, National Electrical Code Copyright, 2001, National Fire Protection Association, Quincy, MA 02269. This reprinted material is not the complete and official position of the National Fire Protection Association on the referenced subject which is represented by the standard in its entirety.

Underwriters Laboratories Inc. is a registered trademark of Underwriters Laboratories Inc., Northbrook, IL 60062. The abbreviation "UL" shall be understood to mean Underwriters Laboratories Inc.

National Electrical Manufacturers Association is located at 2101 L. Street, N.W., Washington, D.C. 20037. The abbreviation "NEMA" is understood to mean National Electrical Manufacturers Association.

AC Motors

AC motors are used worldwide in many residential, commercial, industrial, and utility applications. Motors transform electrical energy into mechanical energy. An AC motor may be part of a pump or fan, or connected to some other form of mechanical equipment such as a winder, conveyor, or mixer. AC motors are found on a variety of applications from those that require a single motor to applications requiring several motors. Siemens manufactures a wide variety of motors for various applications. The material presented in this course will help in selection of a motor for a specific application.

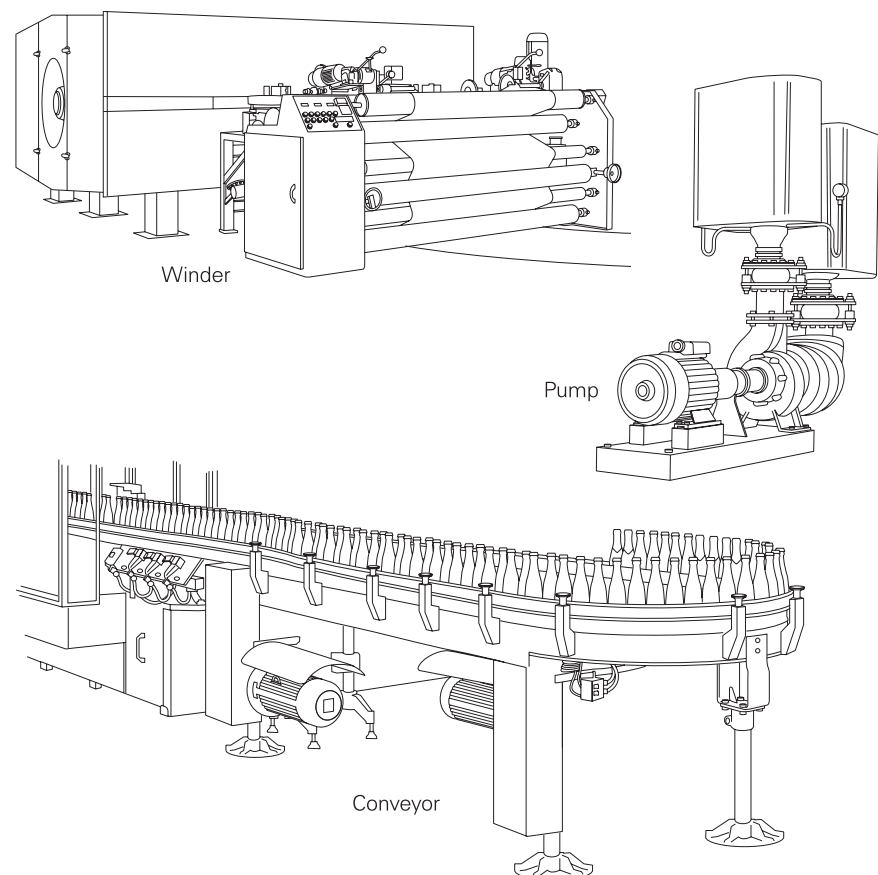

NEMA

Throughout this course reference is made to the National Electrical Manufacturers Association (NEMA). NEMA sets standards for a wide range of electrical products, including motors. NEMA is primarily associated with motors used in North America. The standards developed represent general industry practices and are supported by manufacturers of electrical equipment. These standards can be found in NEMA Standard Publication No. MG 1. Some large AC motors may not fall under NEMA standards. These motors are built to meet the requirements of a specific application. These are referred to as above NEMA motors.



IEC

The International Electrotechnical Commission (IEC) is another organization responsible for motor standards. IEC are a group of recommended electrical practices developed by committees from participating IEC countries. These standards are different than NEMA standards. IEC standards are associated with motors used in many countries, including motors used in North America. These standards can be found in IEC 34-1-16. Motors which meet or exceed these standards are referred to as IEC motors.

Force and Motion

Before discussing AC motors it is necessary to understand some of the basic terminology associated with motor operation. Many of these terms are familiar to us in some other context. Later in the course we will see how these terms apply to AC motors.

Force

In simple terms, a force is a push or a pull. Force may be caused by electromagnetism, gravity, or a combination of physical means.

Net force

Net force is the vector sum of all forces that act on an object, including friction and gravity. When forces are applied in the same direction they are added. For example, if two 10 pound forces were applied in the same direction the net force would be 20 pounds.

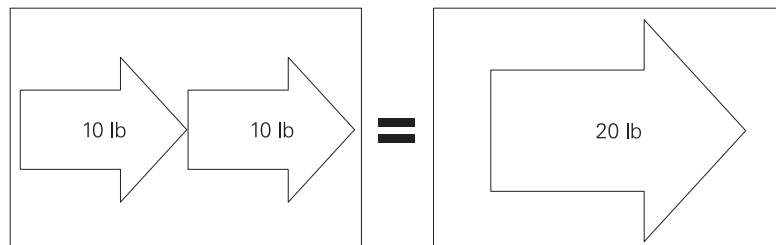

If 10 pounds of force were applied in one direction and 20 pounds of force applied in the opposite direction, the net force would be 10 pounds and the object would move in the direction of the greater force.

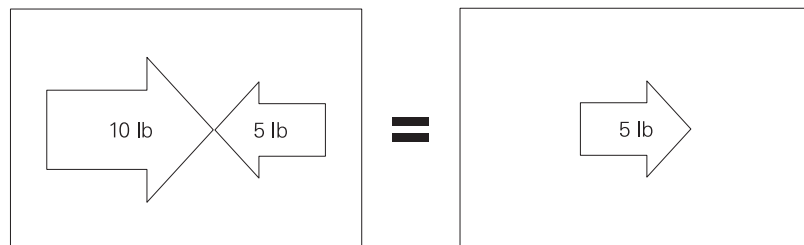

If 10 pounds of force were applied equally in both directions, the net force would be zero and the object would not move.

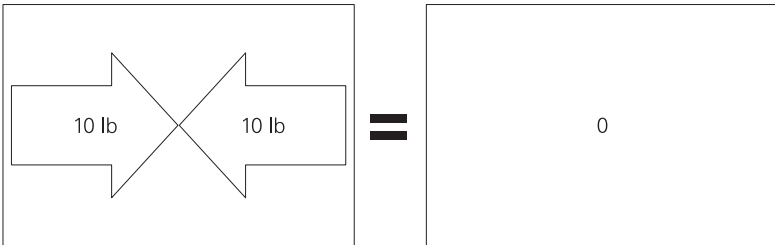

Torque

Torque is a twisting or turning force that causes an object to rotate. For example, a force applied to the end of a lever causes a turning effect or torque at the pivot point.

Torque (τ) is the product of force and radius (lever distance).

$$\tau = \text{Force} \times \text{Radius}$$

In the English system torque is measured in pound-feet (lb-ft) or pound-inches (lb-in). If 10 lbs of force were applied to a lever 1 foot long, for example, there would be 10 lb-ft of torque.

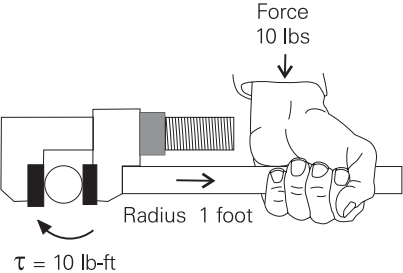

An increase in force or radius would result in a corresponding increase in torque. Increasing the radius to two feet, for example, results in 20 lb-ft of torque.

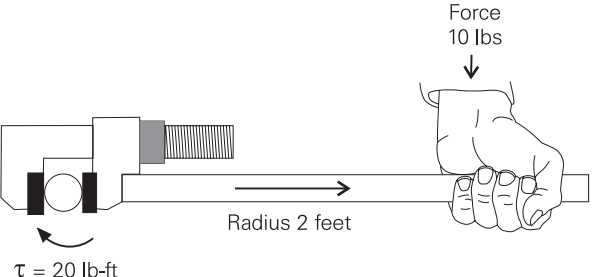

Speed

An object in motion travels a distance in a given time. Speed is the ratio of the distance traveled and the time it takes to travel the distance.

$$\text{Speed} = \frac{\text{Distance}}{\text{Time}}$$

Linear Speed

The linear speed of an object is a measure of how long it takes the object to get from point A to point B. Linear speed is usually given in a form such as meters per second (m/s). For example, if the distance between point A and point B were 10 meters, and it took 2 seconds to travel the distance, the speed would be 5 m/s.



Angular (Rotational) Speed

The angular speed of a rotating object is a measurement of how long it takes a given point on the object to make one complete revolution from its starting point. Angular speed is generally given in revolutions per minute (RPM). An object that makes ten complete revolutions in one minute, for example, has a speed of 10 RPM.

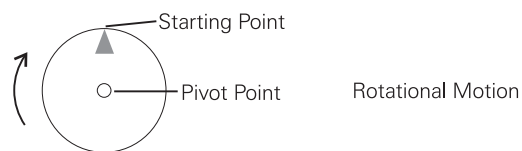

Acceleration

An object can change speed. An increase in speed is called acceleration. Acceleration occurs only when there is a change in the force acting upon the object. An object can also change from a higher to a lower speed. This is known as deceleration (negative acceleration). A rotating object, for example, can accelerate from 10 RPM to 20 RPM, or decelerate from 20 RPM to 10 RPM.



Inertia

Mechanical systems are subject to the law of inertia. The law of inertia states that an object will tend to remain in its current state of rest or motion unless acted upon by an external force. This property of resistance to acceleration/deceleration is referred to as the moment of inertia. The English system of measurement is pound-feet squared ($\text{lb}\cdot\text{ft}^2$).

If we look at a continuous roll of paper, for example, we know that when the roll is stopped it would take a certain amount of force to overcome the inertia of the roll to get it rolling. The force required to overcome this inertia can come from a source of energy such as a motor. Once rolling, the paper will continue unwinding until another force acts on it to bring it to a stop.

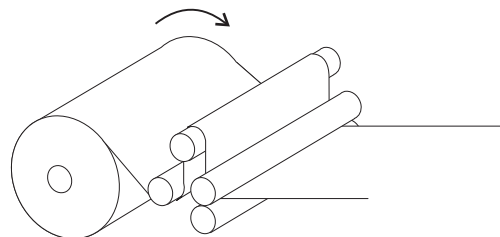

Friction

A large amount of force is applied to overcome the inertia of the system at rest to start it moving. Because friction removes energy from a mechanical system, a continual force must be applied to keep an object in motion. The law of inertia is still valid, however, since the force applied is needed only to compensate for the energy lost.

Once the system is in motion only the energy required to compensate for various losses need be applied to keep the conveyor in motion. In the previous illustration, for example, these losses include:

- Friction within motor and driven equipment bearings
- Wind losses in the motor and driven equipment
- Friction between material on winder and rollers

Work

Whenever a force of any kind causes motion, work is accomplished. For example, work is accomplished when an object on a conveyor is moved from one point to another.

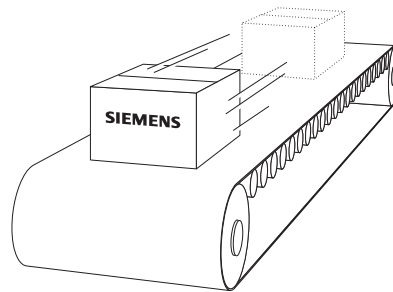

Work is generally expressed in foot-pounds and is defined by the product of the net force (F) applied and the distance (d) moved. If twice the force is applied, twice the work is done. If an object moves twice the distance, twice the work is done.

$$W = F \times d$$

Power

Power is the rate of doing work, or work divided by time.

$$\text{Power} = \frac{\text{Force} \times \text{Distance}}{\text{Time}}$$

$$\text{Power} = \frac{\text{Work}}{\text{Time}}$$

In other words, power is the amount of work it takes to move the package from one point to another point, divided by the time.

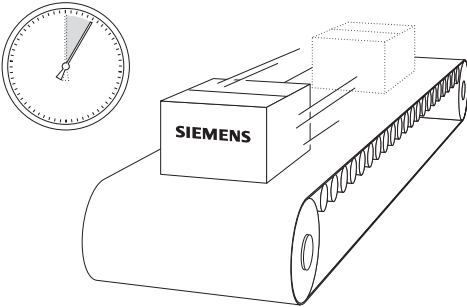

Horsepower

Power can be expressed in foot-pounds per second, but is often expressed in horsepower (HP). This unit was defined in the 18th century by James Watt. Watt sold steam engines and was asked how many horses one steam engine would replace. He had horses walk around a wheel that would lift a weight. He found that each horse would average about 550 foot-pounds of work per second. One horsepower is equivalent to 550 foot-pounds per second or 33,000 foot-pounds per minute.

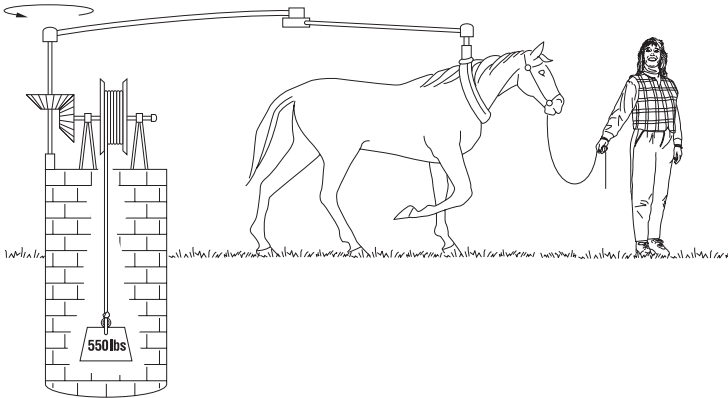

The following formula can be used to calculate horsepower when torque (in lb-feet) and speed are known. An increase of torque, speed, or both will cause an increase in horsepower.

$$HP = \frac{T \times RPM}{5250}$$

Horsepower and kilowatts

AC motors manufactured in the United States are generally rated in horsepower (HP). Equipment manufactured in Europe is generally rated in kilowatts (KW). Horsepower can be converted to kilowatts with the following formula:

$$KW = .746 \times HP$$

For example, a 25 HP motor is equivalent to 18.65 KW.

$$18.65 \text{ KW} = .746 \times 25 \text{ HP}$$

Kilowatts can be converted to horsepower with the following formula:

$$HP = 1.341 \times KW$$

The power formula for a single-phase system is:

$$KW = \frac{V \times I \times PF}{1000}$$

The power formula for three-phase power is:

$$KW = \frac{V \times I \times PF \times 1.732}{1000}$$

Review 1

1. A _____ is a push or a pull.
2. An object has 20 pounds of force applied in one direction and 5 pounds of force applied in the opposite direction. The net force is _____ pounds.
3. A twisting or turning force that causes an object to rotate is known as _____ .
4. If 40 pounds of force were applied to a lever 2 feet long, the torque would be _____ lb-ft.
5. The law of _____ states that an object will tend to remain in its current state of rest or motion unless acted upon by an external force.
6. _____ is the ratio of distance traveled and time.
7. The speed of a rotating object is generally given in _____ per _____ .
8. _____ only occurs when there is a change in an object's state of motion.

AC Motor Construction

AC induction motors are commonly used in industrial applications. The following motor discussion will center around three-phase, 460 VAC, asynchronous, induction motors. An asynchronous motor is a type of motor where the speed of the rotor is other than the speed of the rotating magnetic field. This type of motor is illustrated below. The three basic parts of an AC motor are the rotor, stator, and enclosure.

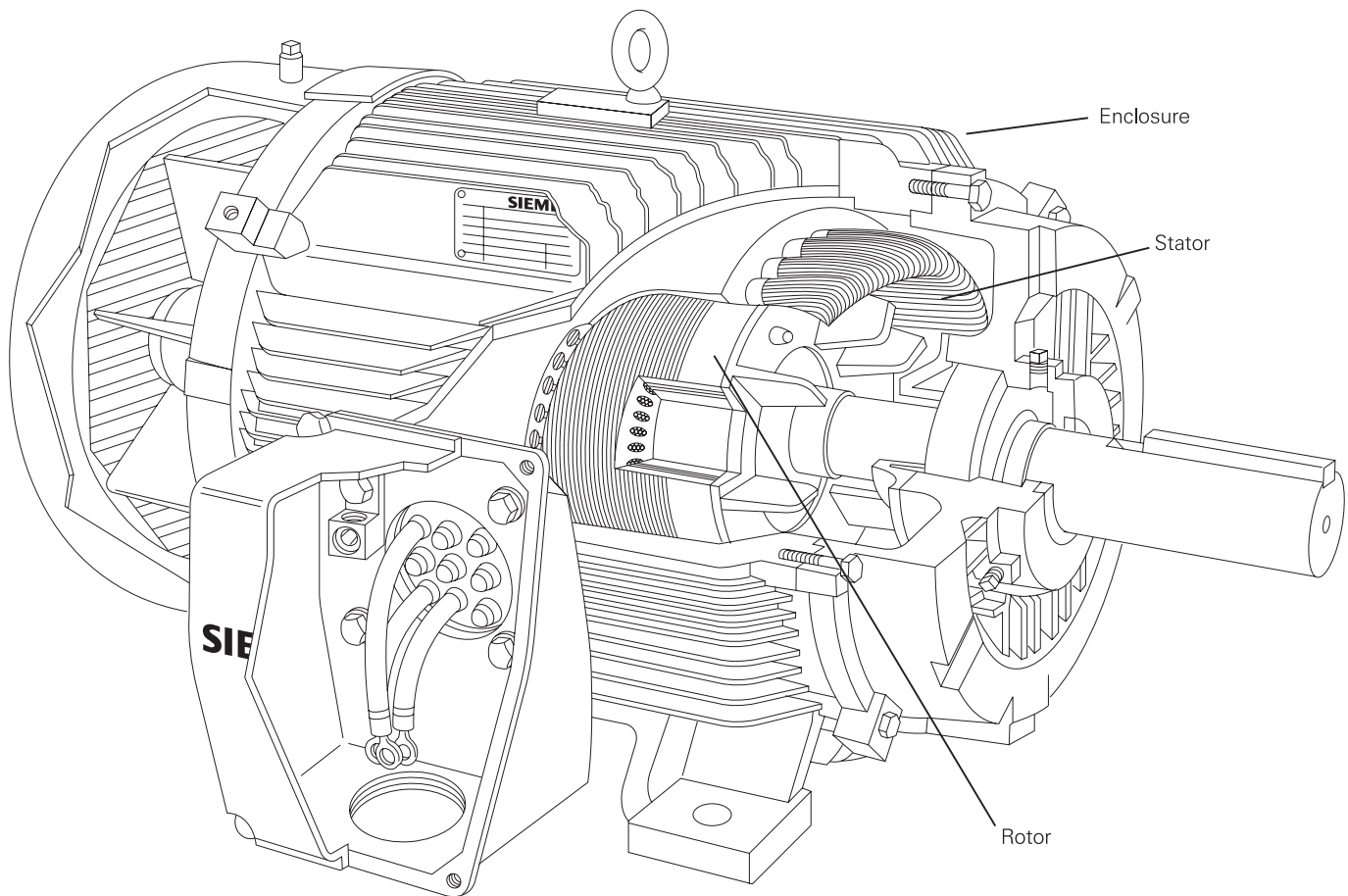

Stator Construction

The stator and the rotor are electrical circuits that perform as electromagnets. The stator is the stationary electrical part of the motor. The stator core of a NEMA motor is made up of several hundred thin laminations.

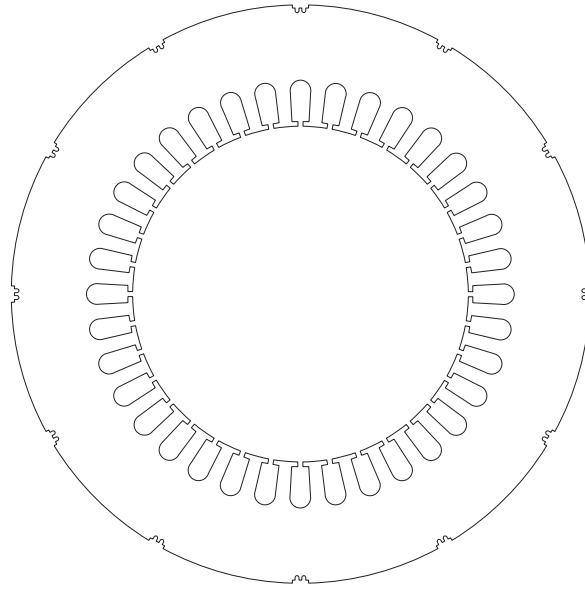

Stator Windings

Stator laminations are stacked together forming a hollow cylinder. Coils of insulated wire are inserted into slots of the stator core.

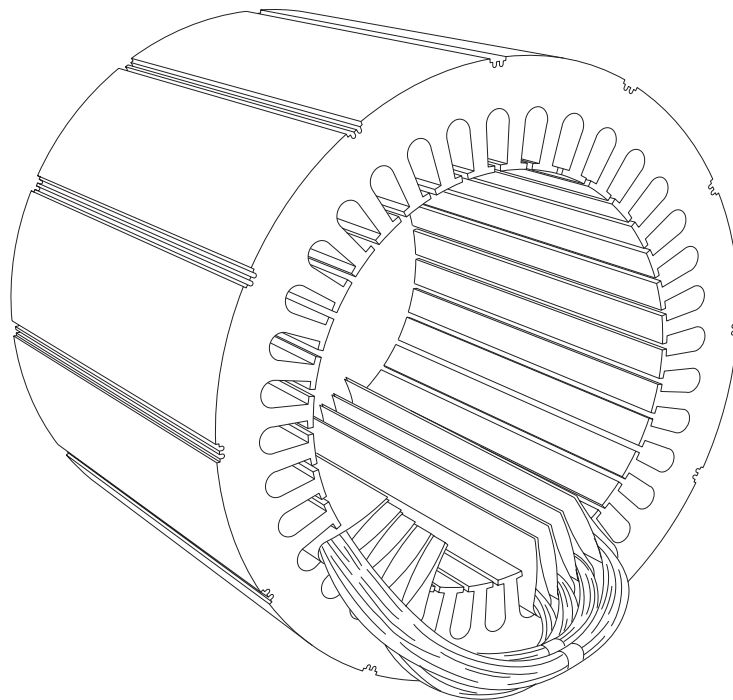

Each grouping of coils, together with the steel core it surrounds, form an electromagnet. Electromagnetism is the principle behind motor operation. The stator windings are connected directly to the power source.

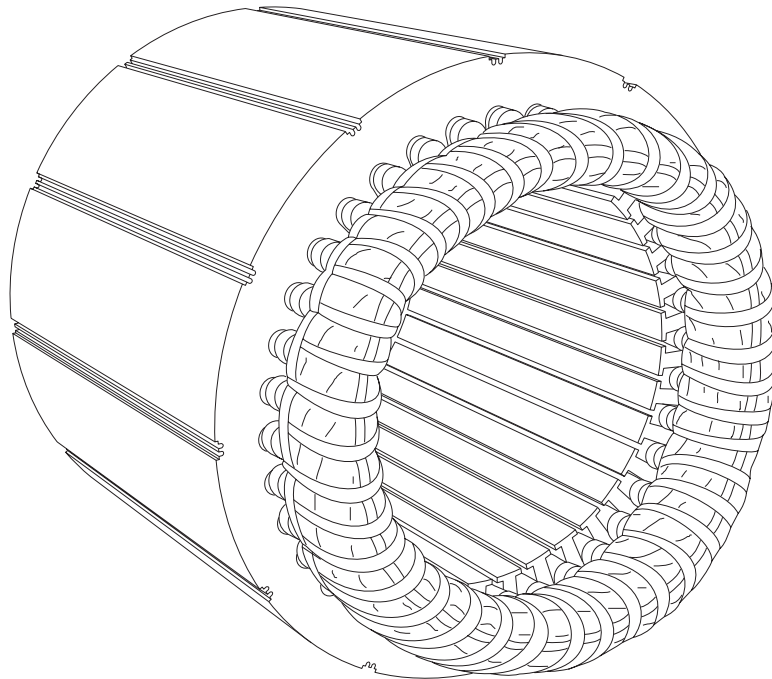

Rotor Construction

The rotor is the rotating part of the electromagnetic circuit. The most common type of rotor is the "squirrel cage" rotor. Other types of rotor construction will be mentioned later in the course. The construction of the squirrel cage rotor is reminiscent of rotating exercise wheels found in cages of pet rodents.

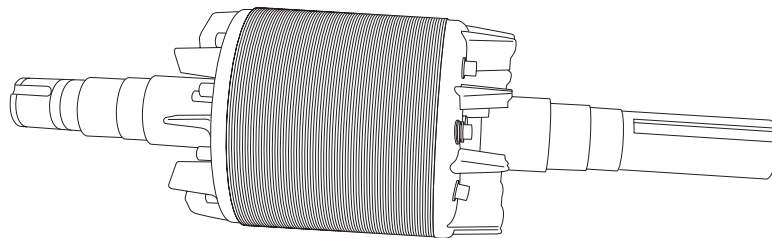

The rotor consists of a stack of steel laminations with evenly spaced conductor bars around the circumference.

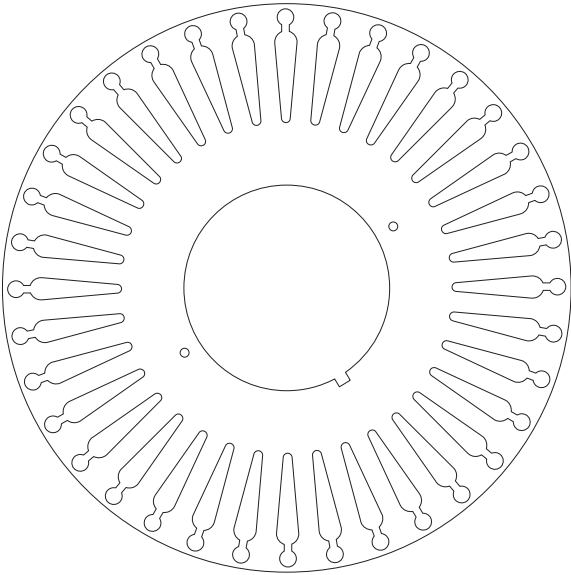

The laminations are stacked together to form a rotor core. Aluminum is die cast in the slots of the rotor core to form a series of conductors around the perimeter of the rotor. Current flow through the conductors form the electromagnet. The conductor bars are mechanically and electrically connected with end rings. The rotor core mounts on a steel shaft to form a rotor assembly.

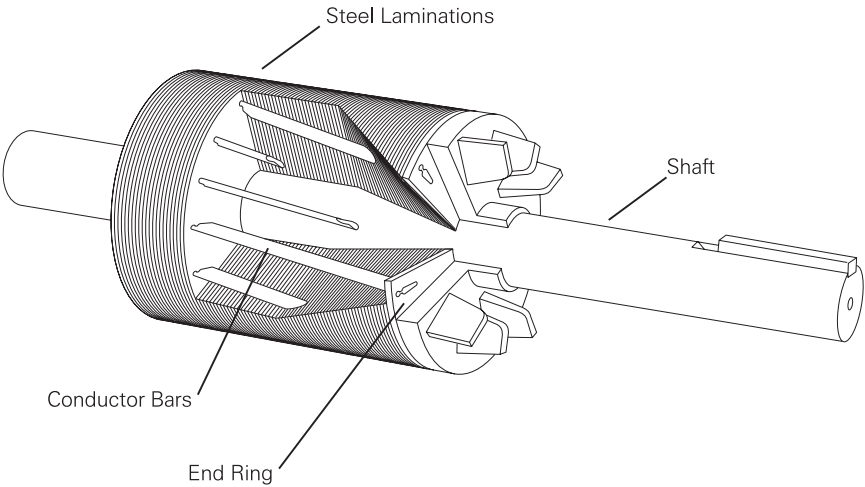

Enclosure

The enclosure consists of a frame (or yoke) and two end brackets (or bearing housings). The stator is mounted inside the frame. The rotor fits inside the stator with a slight air gap separating it from the stator. There is no direct physical connection between the rotor and the stator.

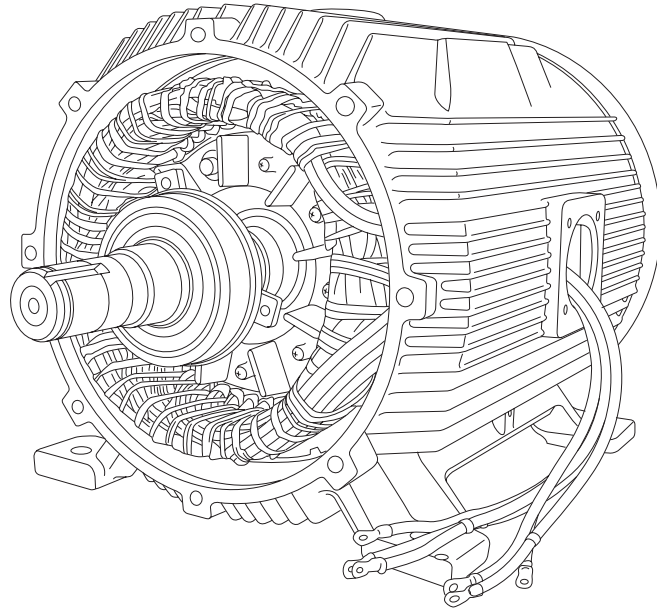

The enclosure also protects the electrical and operating parts of the motor from harmful effects of the environment in which the motor operates. Bearings, mounted on the shaft, support the rotor and allow it to turn. A fan, also mounted on the shaft, is used on the motor shown below for cooling.

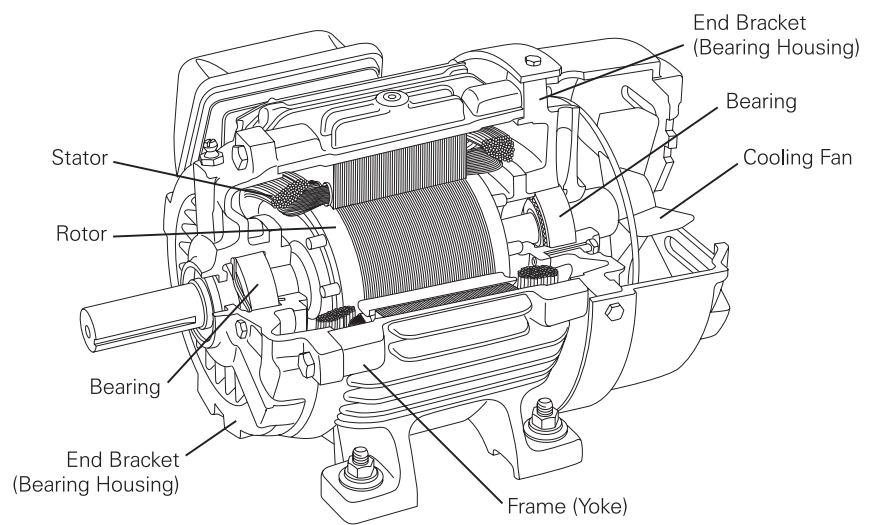

Review 2

1. Identify the following components from the illustration:

A. _____

B. _____

C. _____

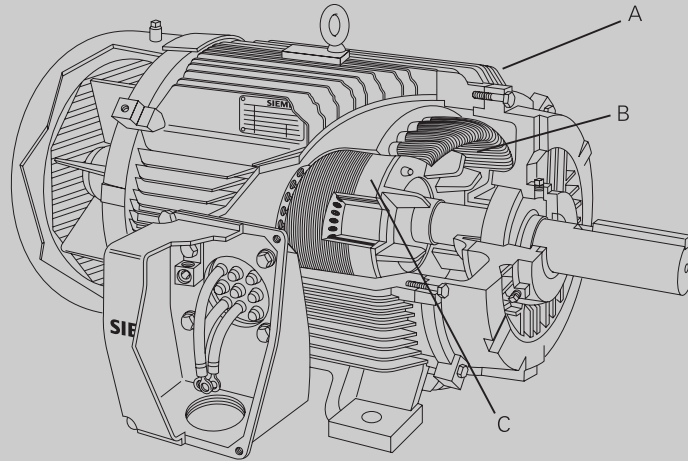

2. The _____ and the _____ are two parts of an electrical circuit that form an electromagnet.

3. The _____ is the stationary electrical part of an AC motor.

4. The _____ is the rotating electrical part of an AC motor.

5. The _____ _____ rotor is the most common type of rotor used in AC motors.

Magnetism

The principles of magnetism play an important role in the operation of an AC motor. All magnets have two characteristics. They attract and hold metal objects like steel and iron. If free to move, like the compass needle, the magnet will assume roughly a north-south position.

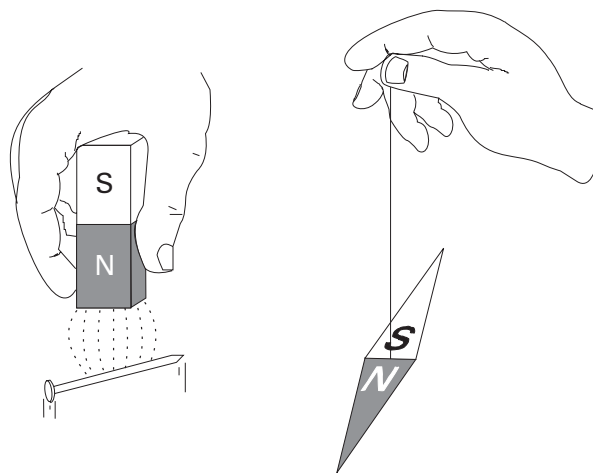

Magnetic Lines of Flux

We know that a magnet attracts an iron or steel object by an invisible force. The magnet's invisible force is called lines of flux. These lines of flux make up an invisible magnetic field. Every magnet has two poles, one north pole and one south pole. Invisible magnetic lines of flux leave the north pole and enter the south pole. While the lines of flux are invisible, the effects of magnetic fields can be made visible. When a sheet of paper is placed on a magnet and iron filings loosely scattered over it, the filings will arrange themselves along the invisible lines of flux.

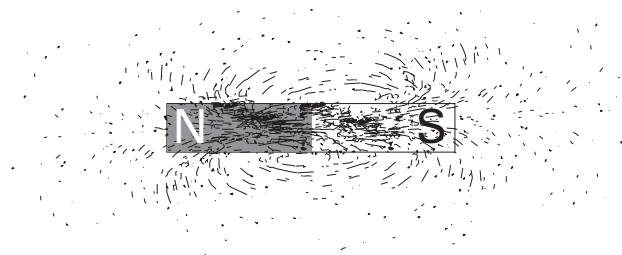

By drawing lines the way the iron filings have arranged themselves, the following illustration is obtained. Magnetic lines of flux always form closed loops, leaving the north pole and entering the south pole. They return to the north pole through the magnet.

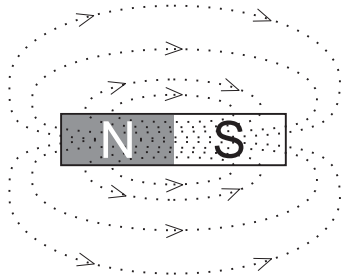

Unlike Poles Attract

The polarity of the magnetic field affects the interaction between magnets. For example, when the opposite poles of two magnets are brought within range of each other the lines of flux combine and tend to pull or attract the magnets.

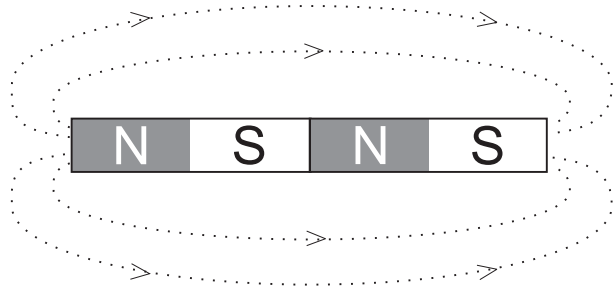

Like Poles Repel

When poles of like polarity of two magnets are brought within range of each other the lines of flux produce a force that tends to push or repel the magnets. For this reason it is said that unlike poles attract and like poles repel. The attracting and repelling action of the magnetic fields is important in the operation of AC motors.

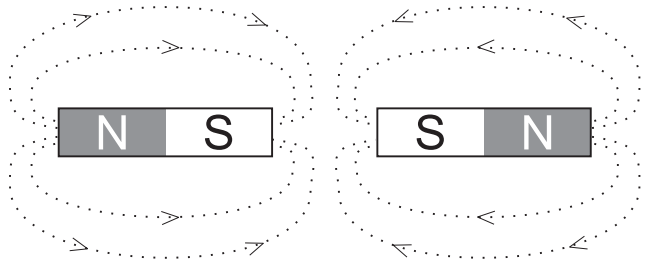

Electromagnetism

When current flows through a conductor a magnetic field is produced around the conductor. The magnetic field is made up of lines of flux, just like a natural magnet. The size and strength of the magnetic field will increase and decrease as the current flow strength increases and decreases.

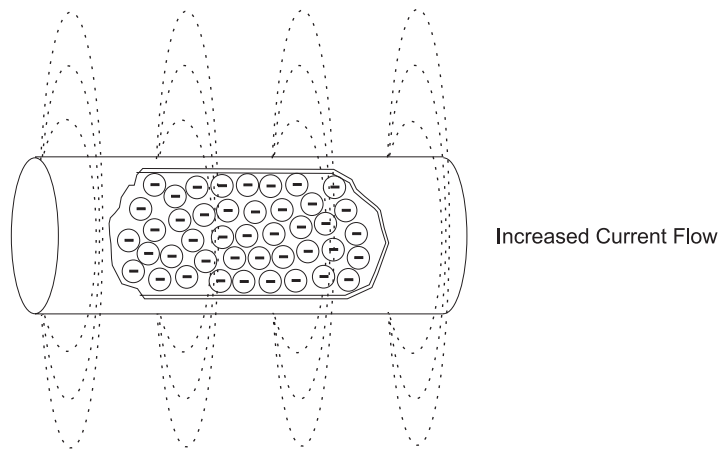
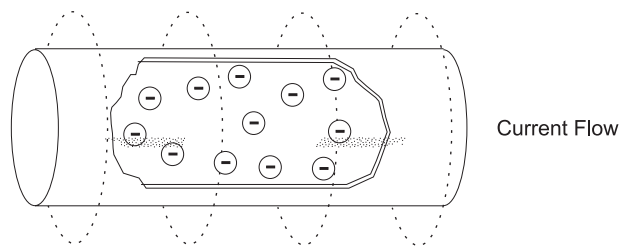

Left-Hand Rule for Conductors

A definite relationship exists between the direction of current flow and the direction of the magnetic field. The left-hand rule for conductors demonstrates this relationship. If a current-carrying conductor is grasped with the left hand with the thumb pointing in the direction of electron flow, the fingers will point in the direction of the magnetic lines of flux.

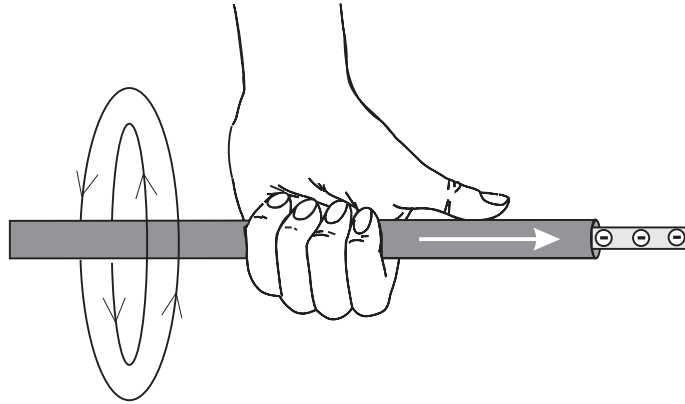

In the following illustration it can be seen that when the electron flow is away from the viewer (indicated by the plus sign) the lines of flux flow in a counterclockwise direction around the conductor. When the electron flow reverses and current flow is towards the viewer (indicated by the dot) the lines of flux reverse direction and flow in a clockwise direction.

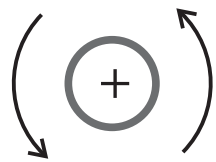

Current Flow
Away From View

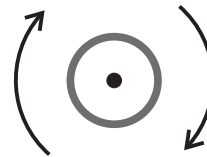

Current Flow
Toward View

Electromagnet

An electromagnet can be made by winding the conductor into a coil and applying a DC voltage. The lines of flux, formed by current flow through the conductor, combine to produce a larger and stronger magnetic field. The center of the coil is known as the core. In this simple electromagnet the core is air.

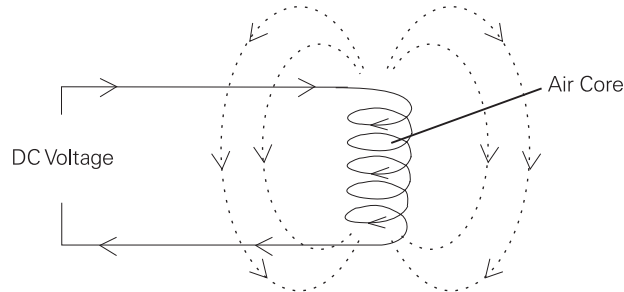

Adding an Iron Core

Iron is a better conductor of flux than air. The air core of an electromagnet can be replaced by a piece of soft iron. When a piece of iron is placed in the center of the coil more lines of flux can flow and the magnetic field is strengthened.

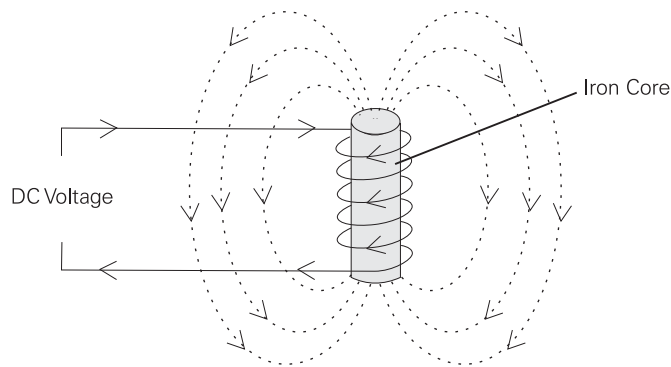

Number of Turns

The strength of the magnetic field in the DC electromagnet can be increased by increasing the number of turns in the coil. The greater the number of turns the stronger the magnetic field.

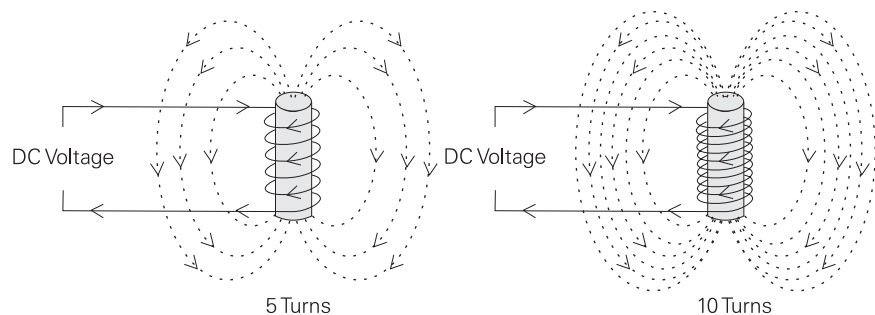

Changing Polarity

The magnetic field of an electromagnet has the same characteristics as a natural magnet, including a north and south pole. However, when the direction of current flow through the electromagnet changes, the polarity of the electromagnet changes. The polarity of an electromagnet connected to an AC source will change at the same frequency as the frequency of the AC source. This can be demonstrated in the following illustration.

At Time 1 current flow is at zero. There is no magnetic field produced around the electromagnet. At Time 2 current is flowing in a positive direction. A magnetic field builds up around the electromagnet. The electromagnet assumes a polarity with the south pole on the top and the north pole on the bottom. At Time 3 current flow is at its peak positive value. The strength of the electromagnetic field is at its greatest value. At Time 4 current flow decreases and the magnetic field begins to collapse, until Time 5 when current flow and magnetic field are at zero. Current immediately begins to increase in the opposite direction. At Time 6 current is increasing in a negative direction. The polarity of the electromagnetic field has changed. The north pole is now on top and the south pole is on the bottom. The negative half of the cycle continues through Times 7 and 8, returning to zero at Time 9. This process will repeat 60 times a second with a 60 Hz AC power supply.

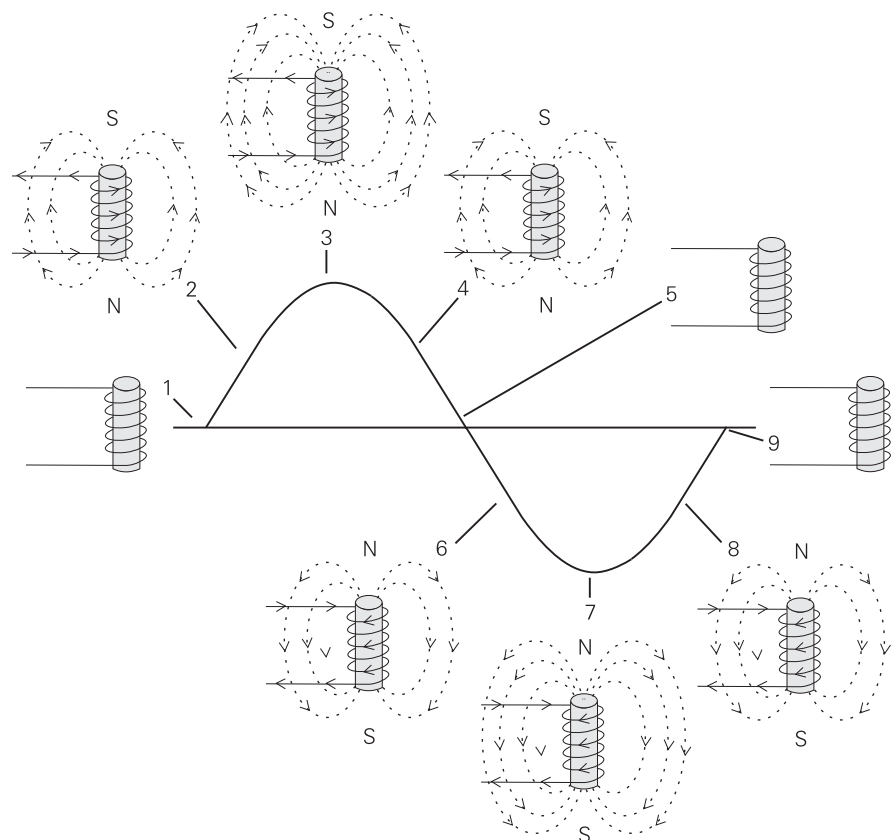

Induced Voltage

A conductor moving through a magnetic field will have a voltage induced into it. This electrical principle is used in the operation of AC induction motors. In the following illustration an electromagnet is connected to an AC power source. Another electromagnet is placed above it. The second electromagnet is in a separate circuit. There is no physical connection between the two circuits.

At Time 1 voltage and current are zero in both circuits. At Time 2 voltage and current are increasing in the bottom circuit. A magnetic field builds up in the bottom electromagnet. Lines of flux from the magnetic field building up in the bottom electromagnet cut across the top electromagnet. A voltage is induced in the top electromagnet and current flows through it. At Time 3 current flow has reached its peak. Maximum current is flowing in both circuits. The magnetic field around the coil continues to build up and collapse as the alternating current continues to increase and decrease. As the magnetic field moves through space, moving out from the coil as it builds up and back towards the coil as it collapses, lines of flux cut across the top coil. As current flows in the top electromagnet it creates its own magnetic field.

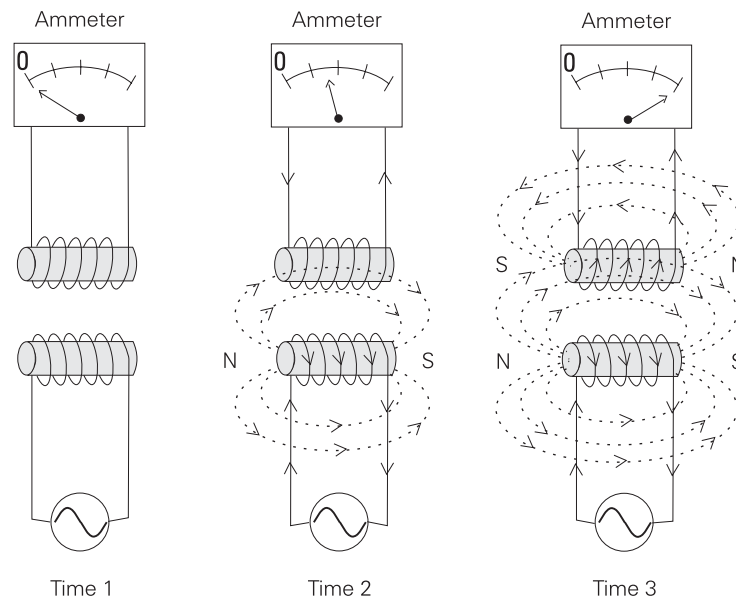

Electromagnetic Attraction

The polarity of the magnetic field induced in the top electromagnet is opposite the polarity of the magnetic field in the bottom electromagnet. Since opposite poles attract, the top electromagnet will follow the bottom electromagnet when it is moved.

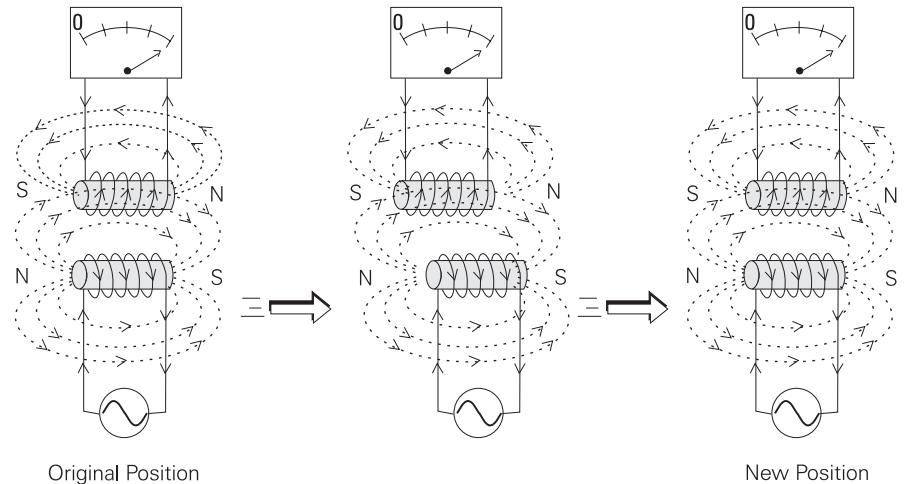

Review 3

- Magnetic lines of flux leave the _____ pole of a magnet and enter the _____ pole.
- In the following illustration, which magnets will attract each other and which magnets will repel each other?
 - | | |
|---|---|
| N | S |
|---|---|

N	S
---	---

 - | | |
|---|---|
| N | S |
|---|---|

S	N
---	---

 - | | |
|---|---|
| S | N |
|---|---|

N	S
---	---

 - | | |
|---|---|
| S | N |
|---|---|

S	N
---	---

- A _____ is produced around a conductor when current is flowing through it.
- Which of the following will not increase the strength of the magnetic field?
 - Increase the current flow
 - Increase the number of turns in a coil
 - Add an iron core to a coil
 - Increase AC power supply frequency

Developing a Rotating Magnetic Field

The principles of electromagnetism explain the shaft rotation of an AC motor. Recall that the stator of an AC motor is a hollow cylinder in which coils of insulated wire are inserted.

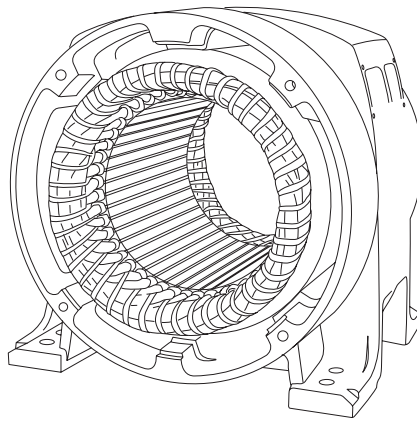

Stator Coil Arrangement

The following schematic illustrates the relationship of the coils. In this example six coils are used, two coils for each of the three phases. The coils operate in pairs. The coils are wrapped around the soft iron core material of the stator. These coils are referred to as motor windings. Each motor winding becomes a separate electromagnet. The coils are wound in such a way that when current flows in them one coil is a north pole and its pair is a south pole. For example, if A1 were a north pole then A2 would be a south pole. When current reverses direction the polarity of the poles would also reverse.

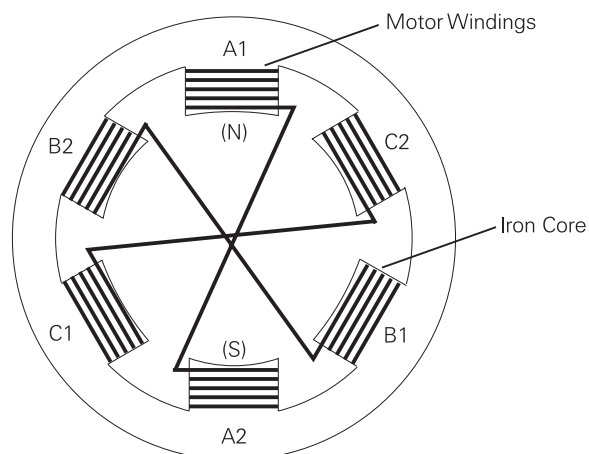

Power Supply

The stator is connected to a 3-phase AC power supply. In the following illustration phase A is connected to phase A of the power supply. Phase B and C would also be connected to phases B and C of the power supply respectively.

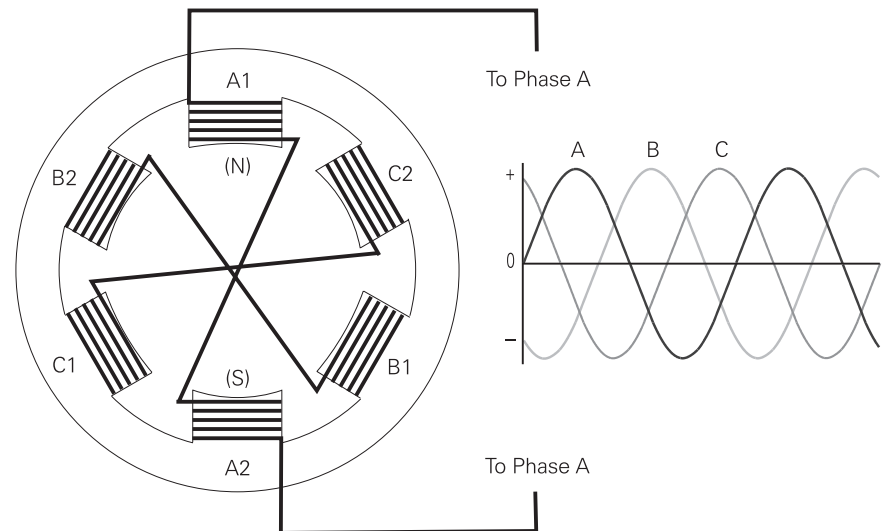

Phase windings (A, B, and C) are placed 120° apart. In this example, a second set of three-phase windings is installed. The number of poles is determined by how many times a phase winding appears. In this example, each phase winding appears two times. This is a two-pole stator. If each phase winding appeared four times it would be a four-pole stator.

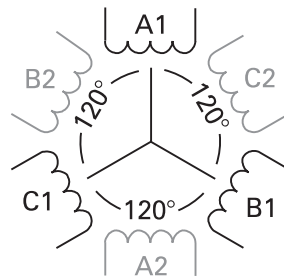

2-Pole Stator Winding

When AC voltage is applied to the stator, current flows through the windings. The magnetic field developed in a phase winding depends on the direction of current flow through that winding. The following chart is used here for explanation only. It will be used in the next few illustrations to demonstrate how a rotating magnetic field is developed. It assumes that a positive current flow in the A1, B1 and C1 windings result in a north pole.

Winding	Current Flow Direction	
	Positive	Negative
A1	North	South
A2	South	North
B1	North	South
B2	South	North
C1	North	South
C2	South	North

Start

It is easier to visualize a magnetic field if a start time is picked when no current is flowing through one phase. In the following illustration, for example, a start time has been selected during which phase A has no current flow, phase B has current flow in a negative direction and phase C has current flow in a positive direction. Based on the above chart, B1 and C2 are south poles and B2 and C1 are north poles. Magnetic lines of flux leave the B2 north pole and enter the nearest south pole, C2. Magnetic lines of flux also leave the C1 north pole and enter the nearest south pole, B1. A magnetic field results, as indicated by the arrow.

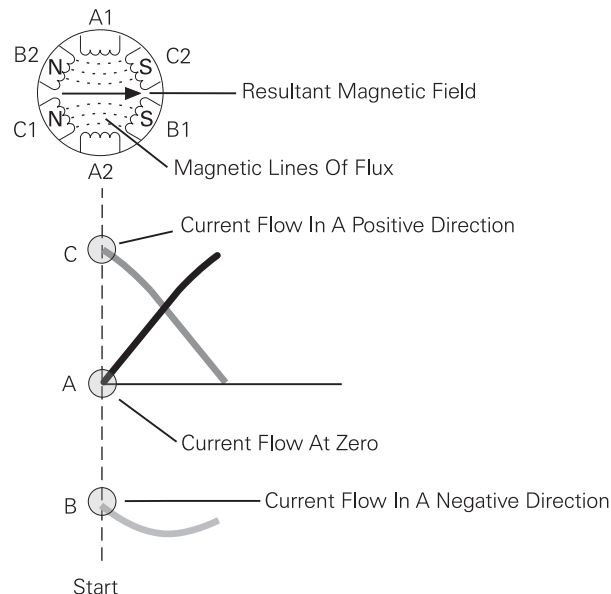

Time 1

If the field is evaluated at 60° intervals from the starting point, at Time 1, it can be seen that the field will rotate 60° . At Time 1 phase C has no current flow, phase A has current flow in a positive direction and phase B has current flow in a negative direction. Following the same logic as used for the starting point, windings A1 and B2 are north poles and windings A2 and B1 are south poles.

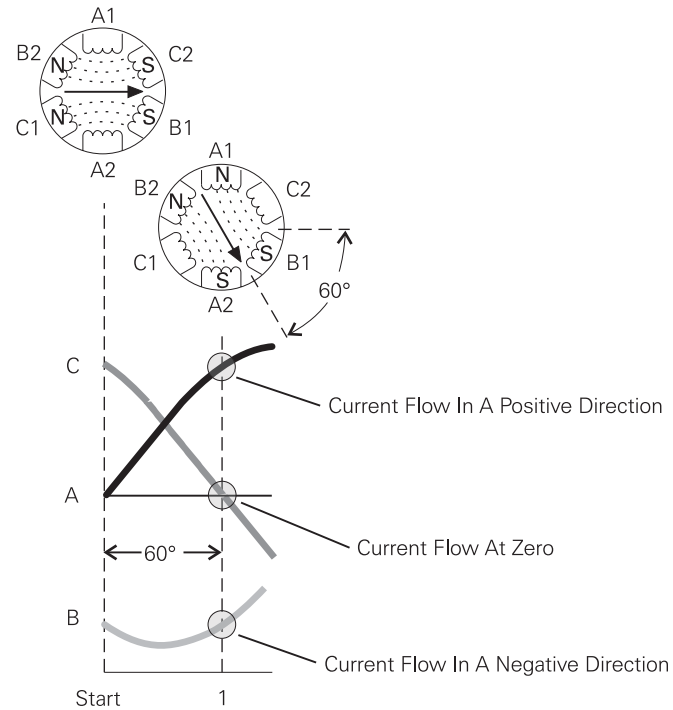

Time 2

At Time 2 the magnetic field has rotated 60° . Phase B has no current flow. Although current is decreasing in phase A it is still flowing in a positive direction. Phase C is now flowing in a negative direction. At start it was flowing in a positive direction. Current flow has changed directions in the phase C windings and the magnetic poles have reversed polarity.

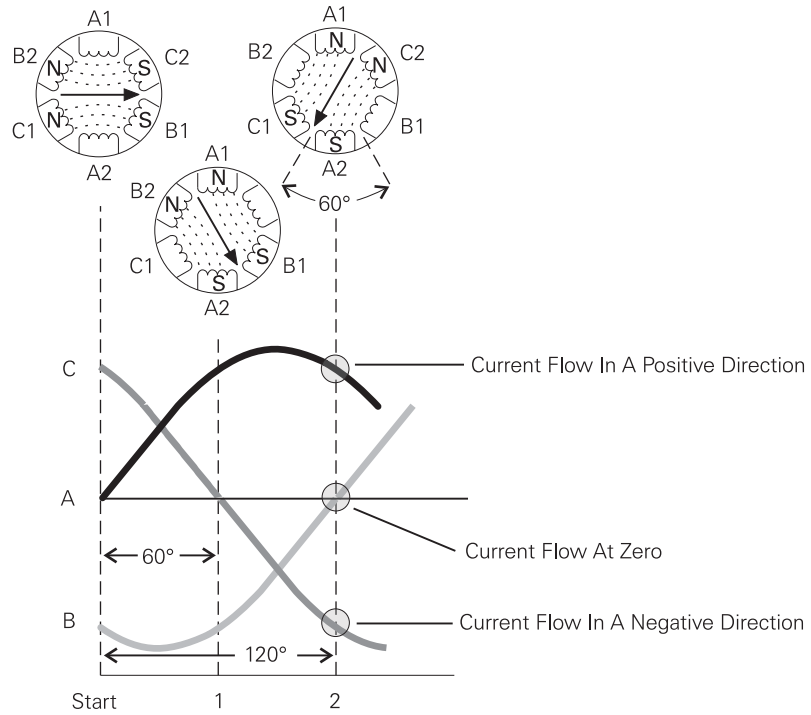

360° Rotation

At the end of six such time intervals the magnetic field will have rotated one full revolution or 360°. This process will repeat 60 times a second on a 60 Hz power supply.

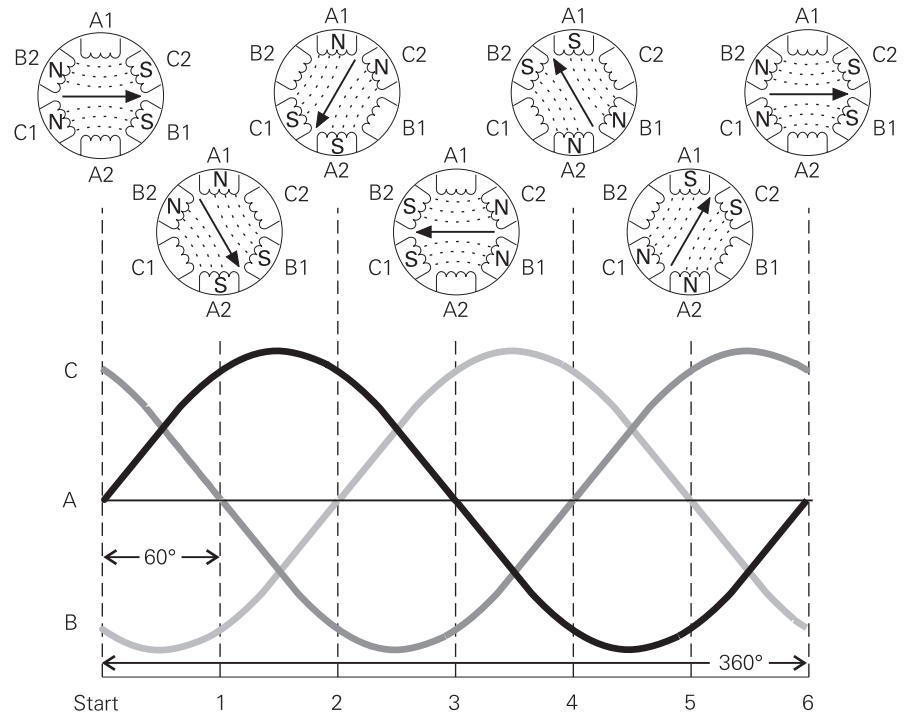

Synchronous Speed

The speed of the rotating magnetic field is referred to as synchronous speed (N_s). Synchronous speed is equal to 120 times the frequency (F), divided by the number of poles (P). The synchronous speed for a two-pole motor operated at 60 Hz, for example, is 3600 RPM.

$$N_s = \frac{120F}{P} \implies N_s = \frac{120 \times 60}{2} \implies N_s = 3600 \text{ RPM}$$

Synchronous speed decreases as the number of poles increase. The following table shows the synchronous speed at 60 Hz for the corresponding number of poles.

No. of Poles	Synchronous Speed
2	3600
4	1800
6	1200
8	900
10	720

Rotor Rotation

Permanent Magnet

To see how a rotor works, a magnet mounted on a shaft can be substituted for the squirrel cage rotor. When the stator windings are energized a rotating magnetic field is established. The magnet has its own magnetic field that interacts with the rotating magnetic field of the stator. The north pole of the rotating magnetic field attracts the south pole of the magnet, and the south pole of the rotating magnetic field attracts the north pole of the magnet. As the rotating magnetic field rotates, it pulls the magnet along causing it to rotate. This design, used on some motors, is referred to as a permanent magnet synchronous motor.

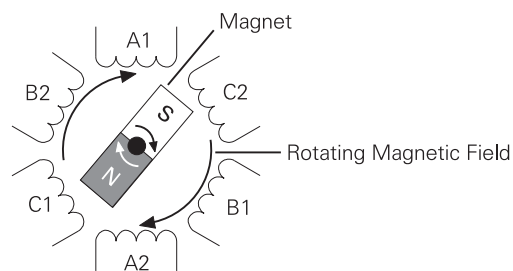

Induced Voltage Electromagnet

The squirrel cage rotor acts essentially the same as the magnet. When power is applied to the stator, current flows through the winding, causing an expanding electromagnetic field which cuts across the rotor bars.

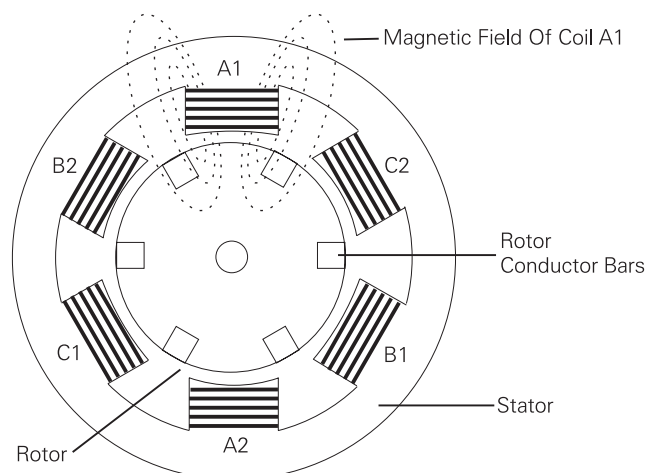

When a conductor, such as a rotor bar, passes through a magnetic field a voltage (emf) is induced in the conductor. The induced voltage causes a current flow in the conductor. Current flows through the rotor bars and around the end ring. The current flow in the conductor bars produces magnetic fields around each rotor bar. Recall that in an AC circuit current continuously changes direction and amplitude. The resultant magnetic field of the stator and rotor continuously change. The squirrel cage rotor becomes an electromagnet with alternating north and south poles.

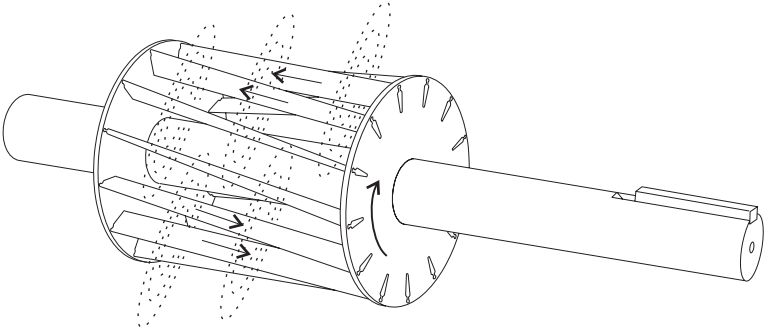

The following drawing illustrates one instant in time during which current flow through winding A1 produces a north pole. The expanding field cuts across an adjacent rotor bar, inducing a voltage. The resultant magnetic field in the rotor tooth produces a south pole. As the stator magnetic field rotates the rotor follows.

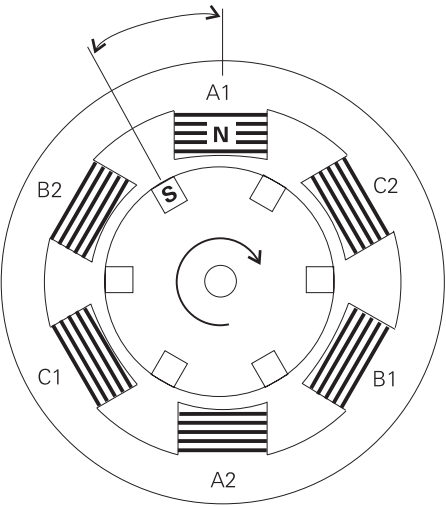

Slip

There must be a relative difference in speed between the rotor and the rotating magnetic field. If the rotor and the rotating magnetic field were turning at the same speed no relative motion would exist between the two, therefore no lines of flux would be cut, and no voltage would be induced in the rotor. The difference in speed is called slip. Slip is necessary to produce torque. Slip is dependent on load. An increase in load will cause the rotor to slow down or increase slip. A decrease in load will cause the rotor to speed up or decrease slip. Slip is expressed as a percentage and can be determined with the following formula.

$$\% \text{ Slip} = \frac{N_s - N_R}{N_s} \times 100$$

For example, a four-pole motor operated at 60 Hz has a synchronous speed (N_s) of 1800 RPM. If the rotor speed at full load is 1765 RPM (N_R), then slip is 1.9%.

$$\% \text{ Slip} = \frac{1800 - 1765}{1800} \times 100$$

$$\% \text{ Slip} = 1.9\%$$

Wound Rotor Motor

The discussion to this point has been centered on the more common squirrel cage rotor. Another type is the wound rotor. A major difference between the wound rotor motor and the squirrel cage rotor is the conductors of the wound rotor consist of wound coils instead of bars. These coils are connected through slip rings and brushes to external variable resistors. The rotating magnetic field induces a voltage in the rotor windings. Increasing the resistance of the rotor windings causes less current flow in the rotor windings, decreasing speed. Decreasing the resistance allows more current flow, speeding the motor up.

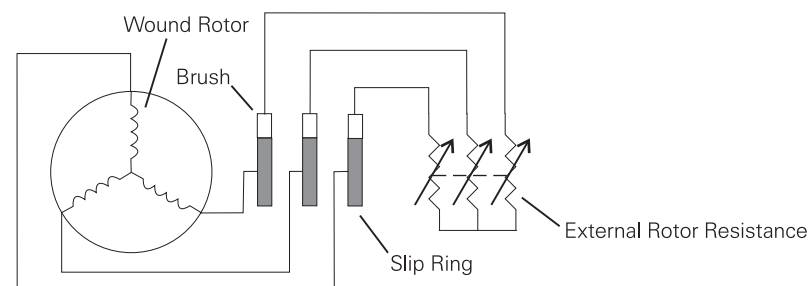

Synchronous Motor

Another type of AC motor is the synchronous motor. The synchronous motor is not an induction motor. One type of synchronous motor is constructed somewhat like a squirrel cage rotor. In addition to rotor bars coil windings are added. The coil windings are connected to an external DC power supply by slip rings and brushes. On start AC is applied to the stator and the synchronous motor starts like a squirrel cage rotor. DC is applied to the rotor coils after the motor reaches maximum speed. This produces a strong constant magnetic field in the rotor which locks in step with the rotating magnetic field. The rotor turns at the same speed as synchronous speed (speed of the rotating magnetic field). There is no slip. Variations of synchronous motors include a permanent magnet rotor. The rotor is a permanent magnet and an external DC source is not required. These are found on small horsepower synchronous motors.

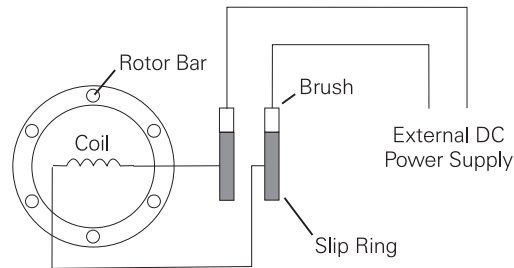

Review 4

1. The following illustration represents a _____ pole motor. If winding A1 is a south pole then winding A2 is a _____ pole.

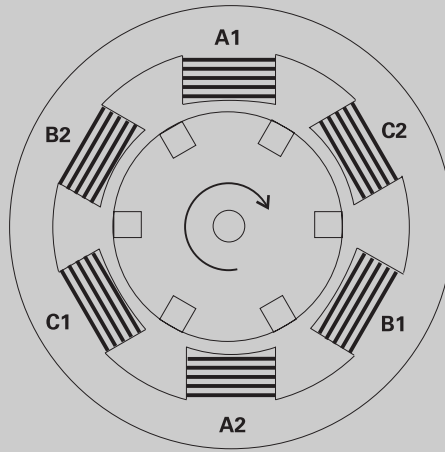

2. The speed of the rotating magnetic field is referred to as _____ speed.
3. The synchronous speed of a 60 Hz 4-pole motor is _____ RPM.
4. The difference in speed between the rotor and synchronous speed is _____ .
5. A 2-pole motor is operating on a 60 Hz power supply. The rotor is turning at 3450 RPM. Slip is _____ %.

Motor Specifications

Nameplate

The nameplate of a motor provides important information necessary for selection and application. The following drawing illustrates the nameplate of a sample 30 horsepower AC motor. Specifications are given for the load and operating conditions as well as motor protection and efficiency.

SIEMENS									
PE•21 PLUS™					PREMIUM EFFICIENCY				
ORD.NO.	1LA02864SE41				E NO.				
TYPE	RGZESD				FRAME	286T			
H. P.	30.00				SERVICE FACTOR	1.15		3 PH	
AMPS	34.9				VOLTS	460			
R.P.M.	1765				HERTZ	60			
DUTY	CONT 40 °C AMB.				DATE CODE				
CLASS INSUL	F	NEMA DESIGN	B	K.V.A. CODE	G	NEMA NOM. EFF.	93.6		
SH. END BRG.	50BC03JPP3				OPP. END BRG.	50BC03JPP3			
MILL AND CHEMICAL DUTY QUALITY INDUCTION MOTOR									
Siemens Energy & Automation, Inc. Little Rock, AR							MADE IN U.S.A.		

Voltage and Amps

AC motors are designed to operate at standard voltages and frequencies. This motor is designed for use on 460 VAC systems. Full-load current for this motor is 34.9 amps.

AMPS	34.9	VOLTS	460
------	------	-------	-----

RPM

Base speed is the nameplate speed, given in RPM, where the motor develops rated horsepower at rated voltage and frequency. It is an indication of how fast the output shaft will turn the connected equipment when fully loaded with proper voltage and frequency applied.

R.P.M.	1765	HERTZ	60
--------	------	-------	----

The base speed of this motor is 1765 RPM at 60 Hz. It is known that the synchronous speed of a 4-pole motor is 1800 RPM. When fully loaded there will be 1.9% slip. If the connected equipment is operating at less than full load, the output speed (RPM) will be slightly greater than nameplate.

$$\% \text{ Slip} = \frac{1800 - 1765}{1800} \times 100$$

$$\% \text{ Slip} = 1.9\%$$

Service Factor

A motor designed to operate at its nameplate horsepower rating has a service factor of 1.0. This means the motor can operate at 100% of its rated horsepower. Some applications may require a motor to exceed the rated horsepower. In these cases a motor with a service factor of 1.15 can be specified. The service factor is a multiplier that may be applied to the rated power. A 1.15 service factor motor can be operated 15% higher than the motor's nameplate horsepower. The 30 HP motor with a 1.15 service factor, for example can be operated at 34.5 HP. It should be noted that any motor operating continuously at a service factor greater than 1 will have a reduced life expectancy compared to operating it at its rated horsepower. In addition, performance characteristics, such as full load RPM and full load current, will be affected.

SERVICE FACTOR	1.15
----------------	------

Class Insulation

The National Electrical Manufacturers Association (NEMA) has established insulation classes to meet motor temperature requirements found in different operating environments. The four insulation classes are A, B, F, and H. Class F is commonly used. Class A is seldom used. Before a motor is started, its windings are at the temperature of the surrounding air. This is known as ambient temperature. NEMA has standardized on an ambient temperature of 40° C, or 104° F within a defined altitude range for all motor classes.

DUTY	CONT	40° C AMB.
CLASS INSUL	F	

Temperature will rise in the motor as soon as it is started. Each insulation class has a specified allowable temperature rise. The combination of ambient temperature and allowed temperature rise equals the maximum winding temperature in a motor. A motor with Class F insulation, for example, has a maximum temperature rise of 105° C when operated at a 1.0 service factor. The maximum winding temperature is 145° C (40° ambient plus 105° rise). A margin is allowed to provide for a point at the center of the motor's windings where the temperature is higher. This is referred to as the motor's hot spot.

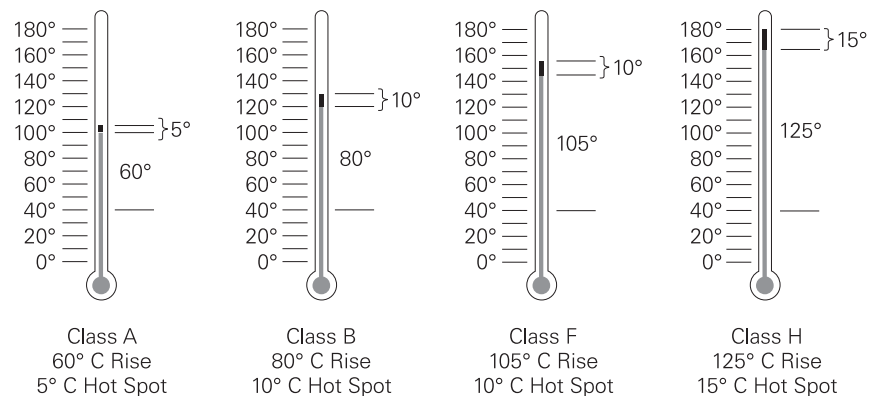

The operating temperature of a motor is important to efficient operation and long life. Operating a motor above the limits of the insulation class reduces the motor's life expectancy. A 10° C increase in the operating temperature can decrease the motor's insulation life expectancy as much as 50%.

Motor Design

The National Electrical Manufacturers Association (NEMA) has established standards for motor construction and performance. NEMA design B motors are most commonly used.

NEMA DESIGN	B
----------------	---

Efficiency

AC motor efficiency is expressed as a percentage. It is an indication of how much input electrical energy is converted to output mechanical energy. The nominal efficiency of this motor is 93.6%. The higher the percentage the more efficiently the motor converts the incoming electrical power to mechanical horsepower. A 30 HP motor with a 93.6% efficiency would consume less energy than a 30 HP motor with an efficiency rating of 83%. This can mean a significant savings in energy cost. Lower operating temperature, longer life, and lower noise levels are typical benefits of high efficiency motors.

NEMA. NOM. EFF	93.6
-------------------	------

NEMA Motor Characteristics

Standard Motor Designs

Motors are designed with certain speed-torque characteristics to match speed-torque requirements of various loads. The four standard NEMA designs are NEMA A, NEMA B, NEMA C, and NEMA D. NEMA A is not used very often. NEMA B is most commonly used. NEMA C and NEMA D are used for specialized applications. A motor must be able to develop enough torque to start, accelerate and operate a load at rated speed. Using the sample 30 HP, 1765 RPM motor discussed previously, torque can be calculated by transposing the formula for horsepower.

$$HP = \frac{T \times RPM}{5250}$$

$$T = \frac{HP \times 5250}{RPM} \quad T = \frac{30 \times 5250}{1765} \quad T = 89.2 \text{ Lb-Ft}$$

Speed-Torque Curve for NEMA B Motor

A graph, like the one shown below, shows the relationship between speed and torque the motor produces from the moment of start until the motor reaches full-load torque at rated speed. This graph represents a NEMA B motor.

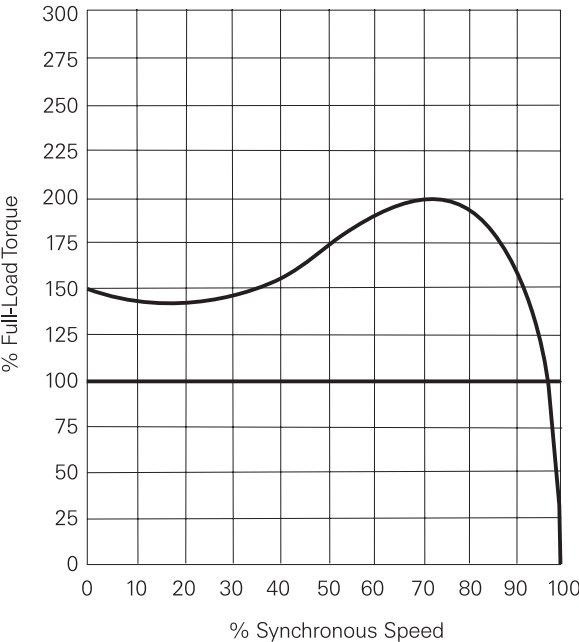

Starting Torque

Starting torque (point A on the graph) is also referred to as locked rotor torque. This torque is developed when the rotor is held at rest with rated voltage and frequency applied. This condition occurs each time a motor is started. When rated voltage and frequency are applied to the stator there is a brief amount of time before the rotor turns. At this instant a NEMA B motor develops approximately 150% of its full-load torque. A 30 HP, 1765 RPM motor, for example, will develop approximately 133.8 Lb-Ft of torque.

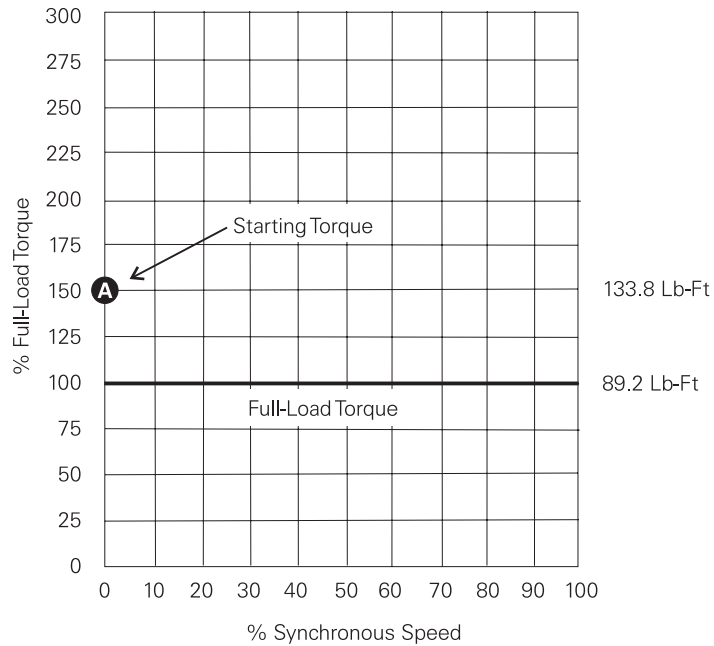

Accelerating and Breakdown Torque

The magnetic attraction of the rotating magnetic field will cause the rotor to accelerate. As the motor picks up speed torque decreases slightly until it reaches point B on the graph. As speed continues to increase from point B to point C torque increases until it reaches its maximum at approximately 200%. This torque is referred to as accelerating or pull up torque. Point C is the maximum torque a motor can produce. At this point a 30 HP motor will develop approximately 178.4 Lb-Ft of torque. If the motor were overloaded beyond the motor's torque capability, it would stall or abruptly slow down at this point. This is referred to as breakdown or pullout torque.

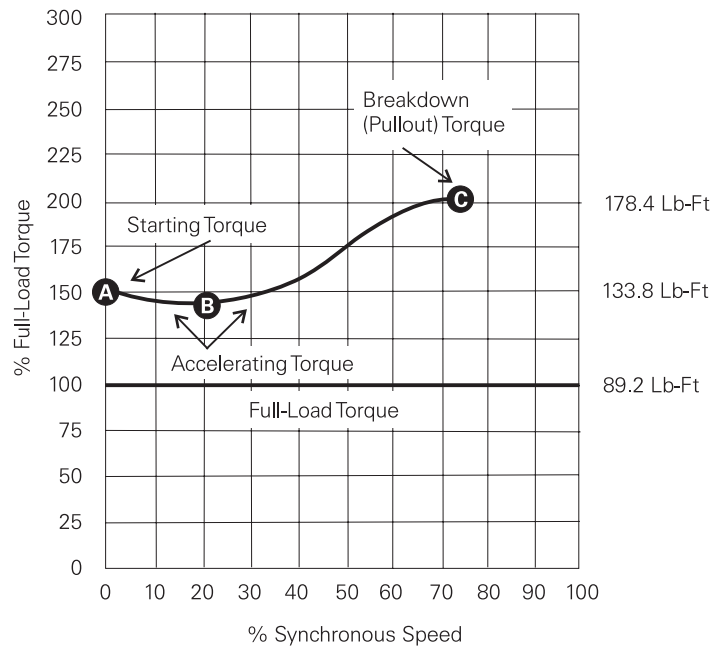

Full-Load Torque

Torque decreases rapidly as speed increases beyond breakdown torque (point C), until it reaches full-load torque at a speed slightly less than 100% synchronous speed. Full-load torque is the torque developed when the motor is operating with rated voltage, frequency and load. The speed at which full-load torque is produced is the slip speed or rated speed of the motor. Recall that slip is required to produce torque. If the synchronous speed of the motor is 1800 RPM and the amount of slip is 1.9%, the full-load rated speed of the motor is 1765 RPM. The full-load torque of the 1765 RPM 30 HP motor is 89.2 Lb-Ft. NEMA design B motors are general purpose single speed motors suited for applications that require normal starting and running torque such as conveyors, fans, centrifugal pumps, and machine tools.

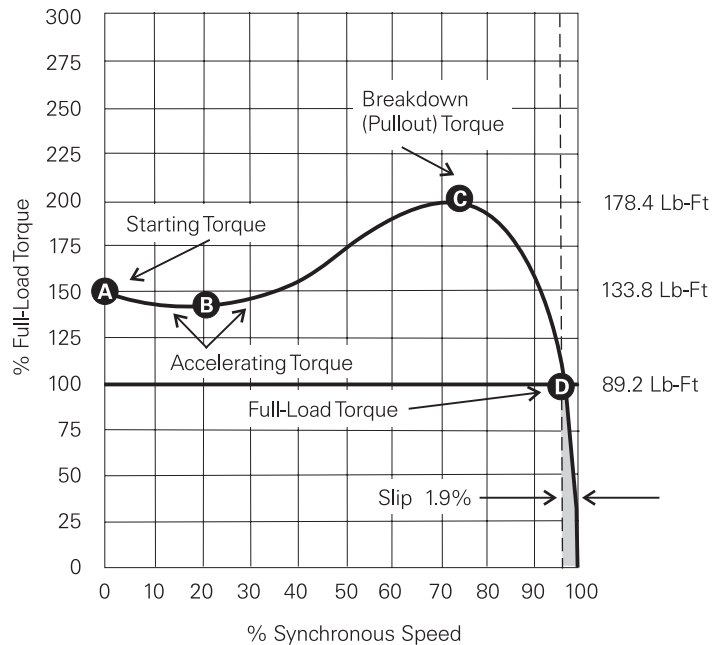

Starting Current and Full-Load Current

Starting current is also referred to as locked rotor current, and is measured from the supply line at rated voltage and frequency with the rotor at rest. Full-load current is the current measured from the supply line at rated voltage, frequency and load with the rotor up to speed. Starting current is typically 600-650% of full-load current on a NEMA B motor. Starting current decreases to rated full-load current as the rotor comes up to speed.

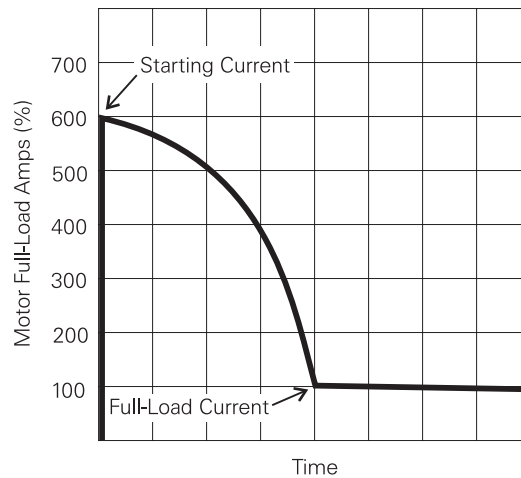

NEMA A Motor

NEMA sets limits of starting (locked rotor) current for NEMA design B motors. When special load torque or load inertia requirements result in special electrical designs that will yield higher locked rotor current (LRA), NEMA design A may result. This designation also cautions the selection of motor control components to avoid tripping protective devices during longer acceleration times or higher than normal starting current.

NEMA C Motor

Starting torque of a NEMA design C motor is approximately 225%. A NEMA C, 1765 RPM, 30 HP motor will develop approximately 202.5 Lb-Ft of starting torque. Hard to start applications such as plunger pumps, heavily loaded conveyors, and compressors require this higher starting torque. Slip and full-load torque are about the same as a NEMA B motor. NEMA C applies to single speed motors from approximately 5 HP to 200 HP.

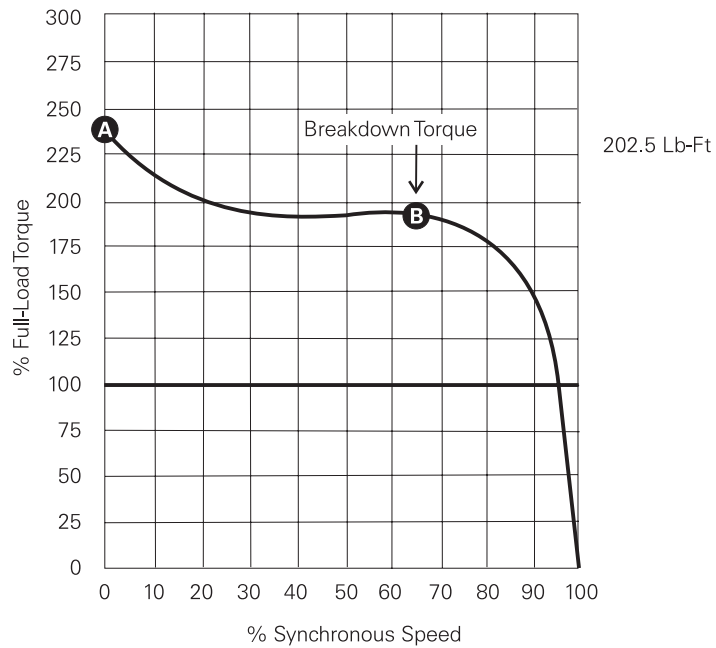

NEMA D Motor

The starting torque of a NEMA design D motor is approximately 280% of the motor's full-load torque. A NEMA D, with a full-load rated speed of 1765 RPM, 30 HP motor will develop approximately 252 Lb-Ft of starting torque. Very hard to start applications, such as punch presses, cranes, hoists, and oil well pumps require this high starting torque. NEMA D motors have no true breakdown torque. After initial starting torque is reached torque decreases until full-load torque is reached. NEMA D motors typically are designed with 5 to 8% slip or 8 to 13% slip.

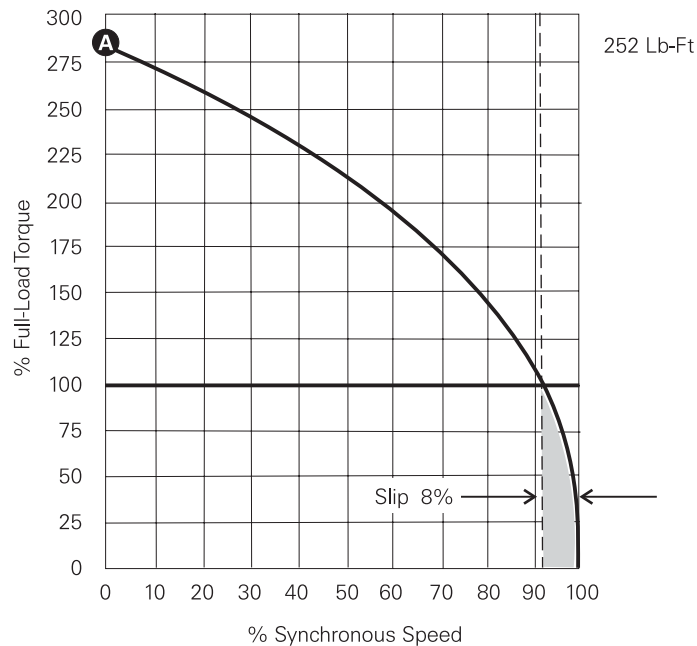

Multispeed and ASD (Adjustable Speed Drive)

These specialized motor designs are uniquely designed or selected to specific load requirements. NEMA design classifications are not applicable to these specialized motors.

Soft Starts

Various special configurations of motor controls are selected when starting/accelerating torques must be more accurately controlled, or when starting current must be limited. In the cases of part winding start or wye-delta start, the motor windings must be designed with unique connections for the special controls. In cases such as reduced voltage autotransformer or electronic soft starts, relatively standard motors may be approved for these special applications.

Review 5

1. A 30 HP motor with a 1.15 service factor can be operated at _____ HP.
2. A motor with Class F insulation has a maximum _____ temperature rise.
3. The starting torque of a NEMA B motor is approximately _____ % of full-load torque.
4. _____ torque refers to point on a torque curve where a motor is overloaded beyond the motor's torque capability, causing the motor to stall or abruptly slow down.

Derating Factors

Several factors can effect the operation and performance of an AC motor. These need to be considered when applying a motor.

Voltage Variation

AC motors are designed to operate on standardized voltages and frequencies. The following table reflects NEMA standards.

Standardized Voltages/Frequencies	
60 Hz	50 Hz
115 VAC	380 VAC
220 VAC	400 VAC
230 VAC	415 VAC
460 VAC	220/380 VAC
575 VAC	

A small variation in supply voltage can have a dramatic affect on motor performance. In the following chart, for example, when voltage is 10% below the rated voltage of the motor, the motor has 20% less starting torque. This reduced voltage may prevent the motor from getting its load started or keeping it running at rated speed. A 10% increase in supply voltage, on the other hand, increases the starting torque by 20%. This increased torque may cause damage during startup. A conveyor, for example, may lurch forward at startup. A voltage variation will cause similar changes in the motor's starting amps, full-load amps, and temperature rise.

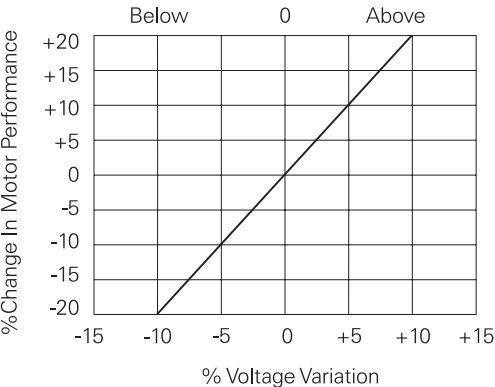

Frequency

A variation in the frequency at which the motor operates causes changes primarily in speed and torque characteristics. A 5% increase in frequency, for example, causes a 5% increase in full-load speed and a 10% decrease in torque.

Frequency Variation	% Change Full-Load Speed	% Change Starting Torque
+5%	+5%	-10%
-5%	-5%	+11%

Altitude

Standard motors are designed to operate below 3300 feet. Air is thinner and heat is not dissipated as quickly above 3300 feet. Most motors must be derated for altitude. The following chart gives typical horsepower derating factors, but the derating factor should be checked for each motor. A 50 HP motor operated at 6000 feet, for example, would be derated to 47 HP, providing the 40°C ambient rating is still required.

Altitude	Derating Factor
3300 - 5000	0.97
5001 - 6600	0.94
6601 - 8300	0.90
8301 - 9900	0.86
9901 - 11,500	0.82

$$50 \text{ HP} \times 0.94 = 47 \text{ HP}$$

Ambient Temperature

The ambient temperature may also have to be considered. The ambient temperature may be reduced from 40°C to 30°C at 6600 feet on many motors. A motor with a higher insulation class may not require derating in these conditions.

Ambient Temperature (°C)	Maximum Altitude (Feet)
40	3300
30	6600
20	9900

AC Motors and AC Drives

Many applications require the speed of an AC motor to vary. The easiest way to vary the speed of an AC induction motor is to use an AC drive to vary the applied frequency. Operating a motor at other than the rated frequency and voltage has an effect on motor current and torque.

Volts per Hertz

A ratio exists between voltage and frequency. This ratio is referred to as volts per hertz (V/Hz). A typical AC motor manufactured for use in the United States is rated for 460 VAC and 60 Hz. The ratio is 7.67 volts per hertz. Not every motor has a 7.67 V/Hz ratio. A 230 Volt, 60 Hz motor, for example, has a 3.8 V/Hz ratio.

$$\frac{460}{60} = 7.67 \text{ V/Hz} \quad \frac{230}{60} = 3.8 \text{ V/Hz}$$

Flux (Φ), magnetizing current (I_M), and torque are all dependent on this ratio. Increasing frequency (F) without increasing voltage (E), for example, will cause a corresponding increase in speed. Flux, however, will decrease causing motor torque to decrease. It can be seen that torque ($T = k\Phi I_w$) is directly affected by flux (Φ). Torque is also affected by the current resulting from the applied load, represented here by I_w . Magnetizing current (I_M) will also decrease. A decrease in magnetizing current will cause a corresponding decrease in stator or line (I_s) current. These decreases are all related and greatly affect the motor's ability to handle a given load.

$$\Phi \approx \frac{E}{F}$$

$$T = k\Phi I_w$$

$$I_M = \frac{E}{2\pi F L_M}$$

Constant Torque

AC motors running on an AC line operate with a constant flux (Φ) because voltage and frequency are constant. Motors operated with constant flux are said to have constant torque. Actual torque produced, however, is determined by the demand of the load.

$$T = k\Phi\omega$$

An AC drive is capable of operating a motor with constant flux (Φ) from approximately zero (0) to the motor's rated nameplate frequency (typically 60 Hz). This is the constant torque range. As long as a constant volts per hertz ratio is maintained the motor will have constant torque characteristics. AC drives change frequency to vary the speed of a motor and changes voltage proportionately to maintain constant flux. The following graphs illustrate the volts per hertz ratio of a 460 volt, 60 Hz motor and a 230 volt, 60 Hz motor. To operate the 460 volt motor at 50% speed with the correct ratio, the applied voltage and frequency would be 230 volts, 30 Hz. To operate the 230 volt motor at 50% speed with the correct ratio, the applied voltage and frequency would be 115 volts, 30 Hz. The voltage and frequency ratio can be maintained for any speed up to 60 Hz. This usually defines the upper limits of the constant torque range.

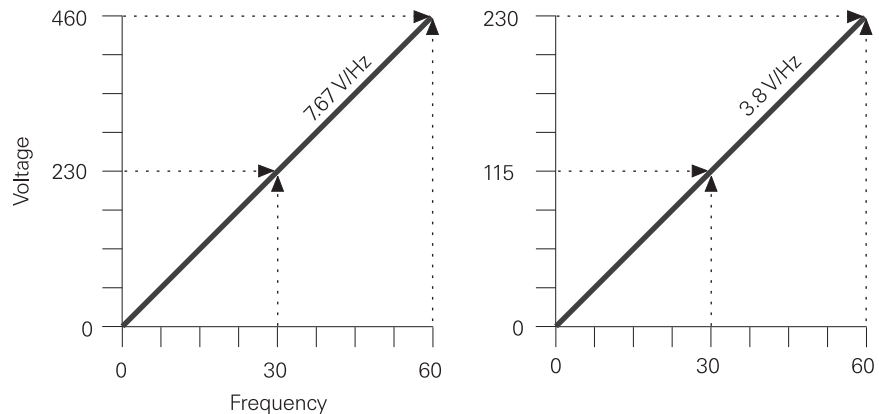

$$\frac{460}{60} = 7.67 \text{ V/Hz}$$

$$\frac{230}{30} = 7.67 \text{ V/Hz}$$

$$\frac{230}{60} = 3.8 \text{ V/Hz}$$

$$\frac{115}{30} = 3.8 \text{ V/Hz}$$

Constant Horsepower

Some applications require the motor to be operated above base speed. The nature of these applications requires less torque at higher speeds. Voltage, however, cannot be higher than the rated nameplate voltage. This can be illustrated using a 460 volt, 60 Hz motor. Voltage will remain at 460 volts for any speed above 60 Hz. A motor operated above its rated frequency is operating in a region known as a constant horsepower. Constant volts per hertz and torque is maintained up to 60 Hz. Above 60 Hz the volts per hertz ratio decreases, with a corresponding decrease in torque.

Frequency	V/Hz
30 Hz	7.67
60 Hz	7.67
70 Hz	6.6
90 Hz	5.1

Flux (Φ) and torque (T) decrease:

$$\Phi \approx \frac{E}{F} \quad T = k\Phi I_w$$

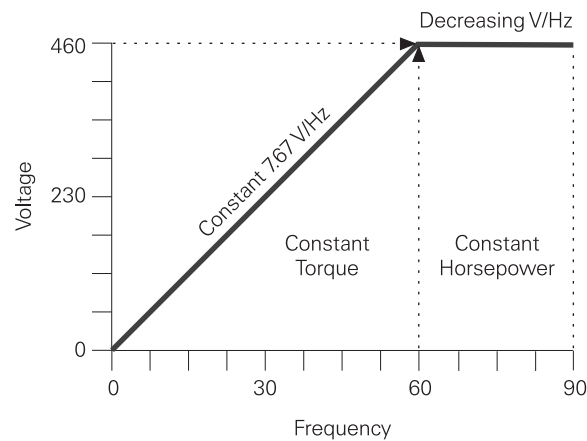

Horsepower remains constant as speed (N) increases and torque decreases in proportion. The following formula applies to speed in revolutions per minute (RPM).

$$\text{HP (remains constant)} = \frac{T \text{ (decreases)} \times N \text{ (increases)}}{5250}$$

Reduced Voltage and Frequency Starting

A NEMA B motor that is started by connecting it to the power supply at full voltage and full frequency will develop approximately 150% starting torque and 600% starting current. AC drives start at reduced voltage and frequency. The motor will start with approximately 150% torque and 150% current at reduced frequency and voltage. The torque/speed curve shifts to the right as frequency and voltage are increased. The dotted lines on the torque/speed curve illustrated below represent the portion of the curve not used by the drive. The drive starts and accelerates the motor smoothly as frequency and voltage are gradually increased to the desired speed. An AC drive, properly sized to a motor, is capable of delivering 150% torque at any speed up to speed corresponding to the incoming line voltage. The only limitations on starting torque are peak drive current and peak motor torque, whichever is less.

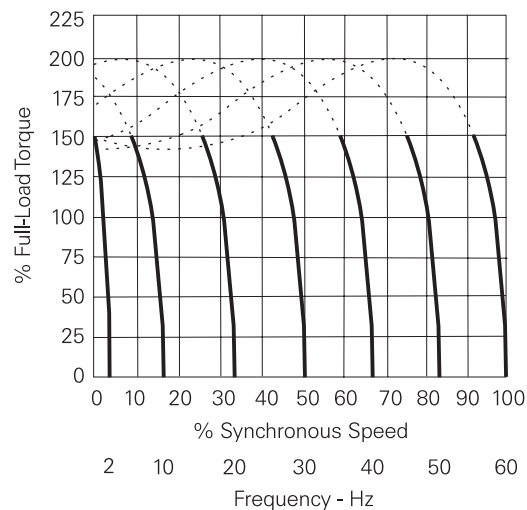

Some applications require higher than 150% starting torque. A conveyor, for example, may require 200% rated torque for starting. If a motor is capable of 200% torque at 200% current, and the drive is capable of 200% current, then 200% motor torque is possible. Typically drives are capable of producing 150% of drive nameplate rated current for one (1) minute. If the load requires more starting torque than a drive can deliver, a drive with a higher current rating would be required. It is appropriate to supply a drive with a higher continuous horsepower rating than the motor when high peak torque is required.

Selecting a Motor

AC drives often have more capability than the motor. Drives can run at higher frequencies than may be suitable for an application. Above 60 Hz the V/Hz ratio decreases and the motor cannot develop 100% torque. In addition, drives can run at low speeds, however, self-cooled motors may not develop enough air flow for cooling at reduced speeds and full load. Each motor must be evaluated according to its own capability before selecting it for use on an AC drive.

Harmonics, voltage spikes, and voltage rise times of AC drives are not identical. Some AC drives have more sophisticated filters and other components designed to minimize undesirable heating and insulation damage to the motor. This must be considered when selecting an AC drive/motor combination. Motor manufacturers will generally classify certain recommended motor selections based on experience, required speed range, type of load torque, and temperature limits.

Distance Between Drive and Motor

Distance from the drive to the motor must also be taken into consideration. All motor cables have line-to-line and line-to-ground capacitance. The longer the cable, the greater the capacitance. Some types of cables, such as shielded cable or cables in metal conduit, have greater capacitance. Spikes occur on the output of AC drives because of the charging current in the cable capacitance. Higher voltage (460 VAC) and higher capacitance (long cables) result in higher current spikes. Voltage spikes caused by long cable lengths can potentially shorten the life of the AC drive and motor. When considering an application where distance may be a problem, contact your local Siemens representative.

Service Factor on AC Drives

A high efficiency motor with a 1.15 service factor is recommended when used on an AC drive. Due to heat associated with harmonics of an AC drive, the 1.15 service factor is reduced to 1.0.

Matching AC Motors to the Load

One way to evaluate whether the torque capabilities of a motor meet the torque requirements of the load is to compare the motor's speed-torque curve with the speed-torque requirements of the load.

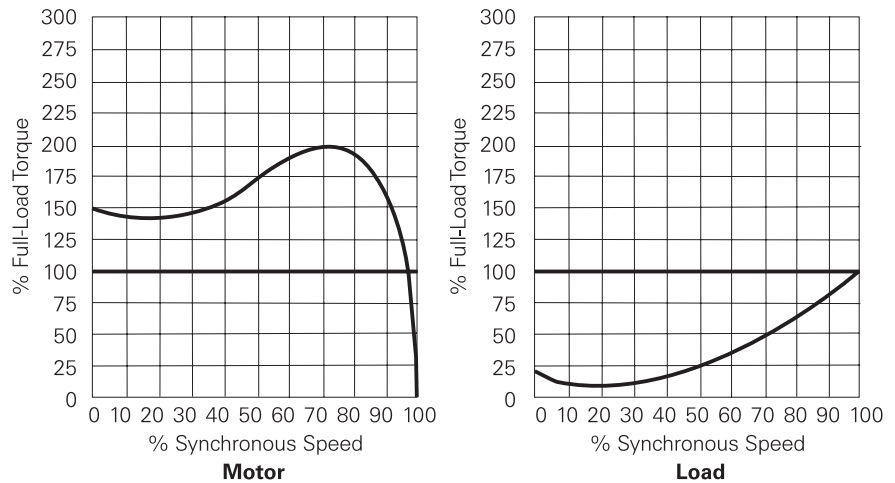

Load Characteristics Tables

To find the torque characteristics a table, similar to the partial one shown below, can be used. NEMA publication MG 1 is one source of typical torque characteristics.

Load Description	Load Torque as % Full-Load Drive Torque		
	Break-away	Accelerating	Peak Running
Actuators:			
Screw-down (rolling mills)	200	150	125
Positioning	150	110	100
Agitators			
Liquid	100	100	100
Slurry	150	100	100
Blowers, centrifugal:			
Valve closed	30	50	40
Valve open	40	110	100
Blowers, positive displacement, rotary, bypassed	40	40	100
Calenders, textile or paper	75	110	100

Calculating Load Torque

The most accurate way to obtain torque characteristics of a given load is from the equipment manufacturer. A simple experiment can be set up to show how torque of a given load can be calculated. In the following illustration a pulley is fastened to the shaft of a load. A cord is wrapped around the pulley with one end connected to a spring scale. The torque can be calculated by pulling on the scale until the shaft turns and noting the reading on the scale. The force required to turn the shaft, indicated by the scale, times the radius of the pulley equals the torque value. It must be remembered that the radius is measured from the center of the shaft. If the radius of the pulley and shaft were 1 foot, for example, and the force required to turn the shaft were 10 pounds, the torque requirement is 10 Lb-Ft. The amount of torque required to turn the connected load can vary at different speeds.

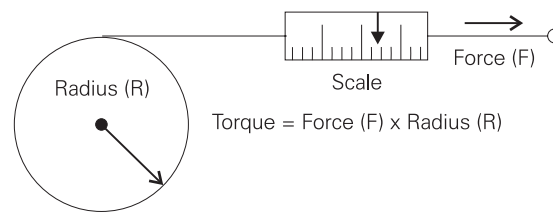

Centrifugal Pump

At any point during acceleration and while the motor is operating at full-load speed, the amount of torque produced by the motor must always exceed the torque required by the load. In the following example a centrifugal pump has a full-load torque of 600 Lb-Ft. This is equivalent to 200 HP. The centrifugal pump only requires approximately 20% of full-load torque to start. The torque dips slightly after it is started and then increases to full-load torque as the pump comes up to speed. This is typically defined as a variable torque load.

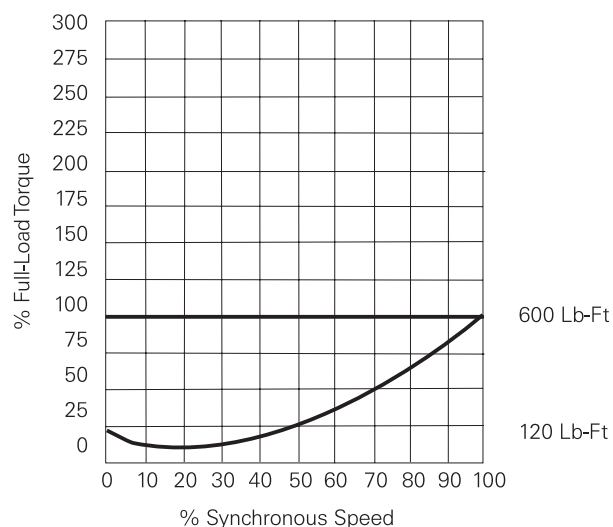

A motor has to be selected that can start and accelerate the centrifugal pump. By comparing a 200 HP NEMA B motor curve to the load curve, it can be seen that the motor will easily start and accelerate the load.

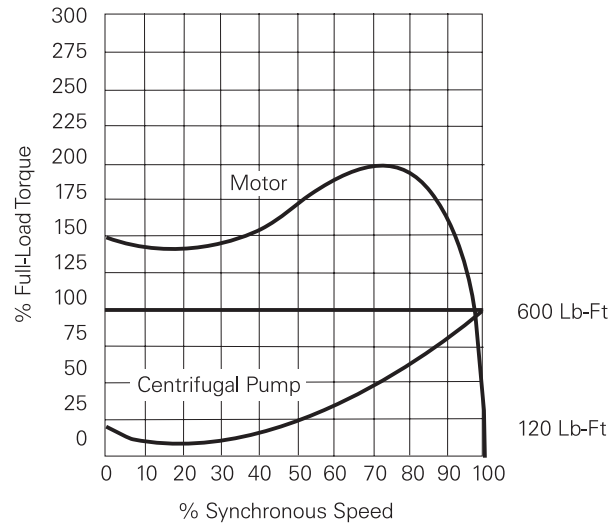

Screw Down Actuator

In the following example a screw down actuator is used. The starting torque of a screw down actuator is approximately 200% of full-load torque. Comparing the load's requirement (200%) with the NEMA design B motor of equivalent horsepower, it can be seen that the load's starting torque requirement is greater than the motor's capability (150%). The motor, therefore, will not start and accelerate the load.

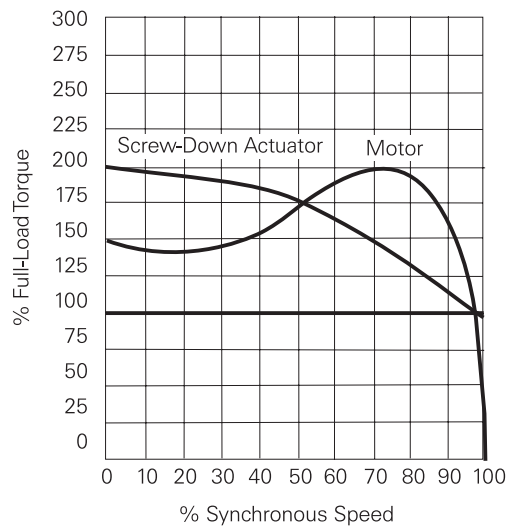

One solution would be to use a higher horsepower NEMA B motor. A less expensive solution might be to use a NEMA D motor of the same horsepower requirements as the load. A NEMA D motor would easily start and accelerate the load.

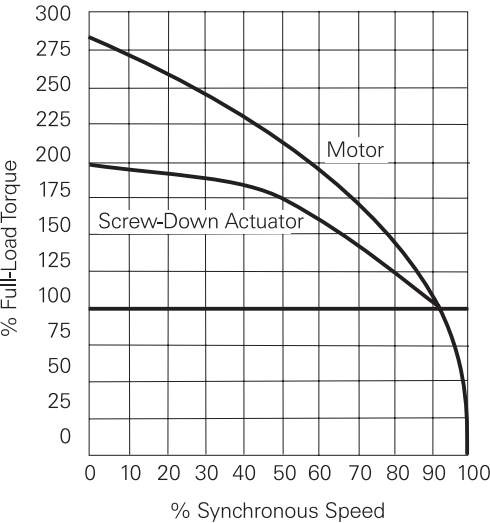

The motor selected to drive the load must have sufficient torque to start, accelerate, and run the load. If, at any point, the motor cannot produce the required torque the motor will stall or run in an overloaded condition. This will cause the motor to generate excess heat and typically exceed current limits causing protective devices to remove the motor from the power source. If the overload condition is not corrected, or the proper motor installed, the existing motor will eventually fail.

Review 6

1. A motor rated for 460 VAC operating on an a supply of 437 VAC (-5%) will have a negative _____ % change in motor performance.
2. Using the altitude derating table the “Derating Factors” section, a 200 HP motor operated at 5500 feet would be derated to _____ HP.
3. The volts per hertz ratio of a 460 Volt 60 Hz motor is _____ V/Hz.
4. When applying an AC motor to an AC drive a motor with a _____ service factor is recommended.
5. If the radius of a pulley and shaft were 2 feet, and the force required to turn the shaft were 20 pounds, the amount of torque required to turn the load is _____ Lb-Ft.

Enclosures

Recall that the enclosure provides protection from contaminants in the environment in which the motor is operating. In addition, the type of enclosure affects the cooling of the motor. There are two categories of enclosures: open and totally enclosed.

Open Drip Proof (ODP)

Open enclosures permit cooling air to flow through the motor. The rotor has fan blades that assist in moving the air through the motor. One type of open enclosure is the drip proof enclosure. The vent openings on this type of enclosure prevent liquids and solids falling from above at angles up to 15° from vertical from entering the interior of the motor and damaging the operating components. When the motor is not in the horizontal position, such as mounted on a wall, a special cover may be necessary to protect it. This type of enclosure can be specified when the environment is free from contaminants.

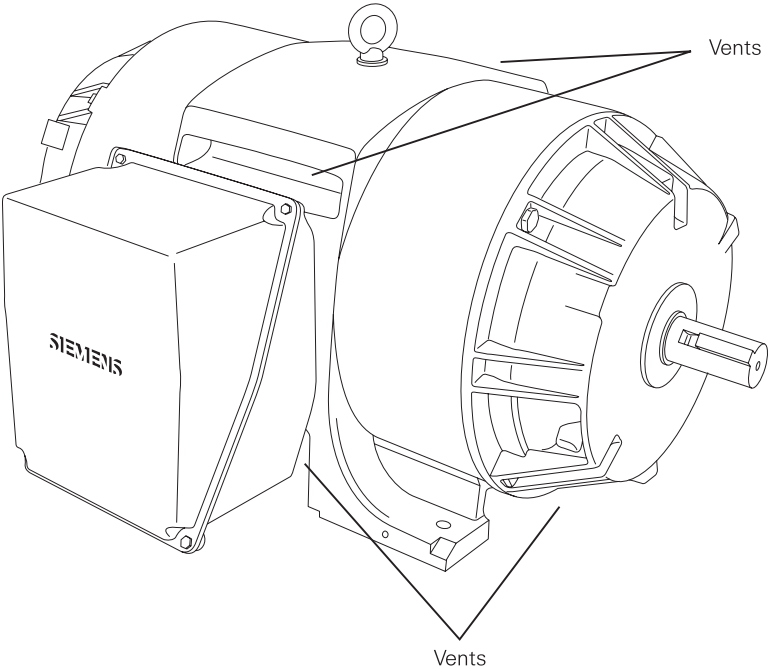

Totally Enclosed Non-Ventilated (TENV)

In some cases air surrounding the motor contains corrosive or harmful elements which can damage the internal parts of a motor. A totally enclosed motor enclosure restricts the free exchange of air between the inside of the motor and the outside. The enclosure is not airtight, however, and a seal at the point where the shaft passes through the housing keeps out water, dust, and other foreign matter that could enter the motor along the shaft. The absence of ventilating openings means all heat dissipates through the enclosure by means of conduction. Most TENV motors are fractional horsepower. TENV motors are used, however, for larger horsepower special applications. For larger horsepower applications the frame is heavily ribbed to help dissipate heat more quickly. TENV motors can be used indoors and outdoors.

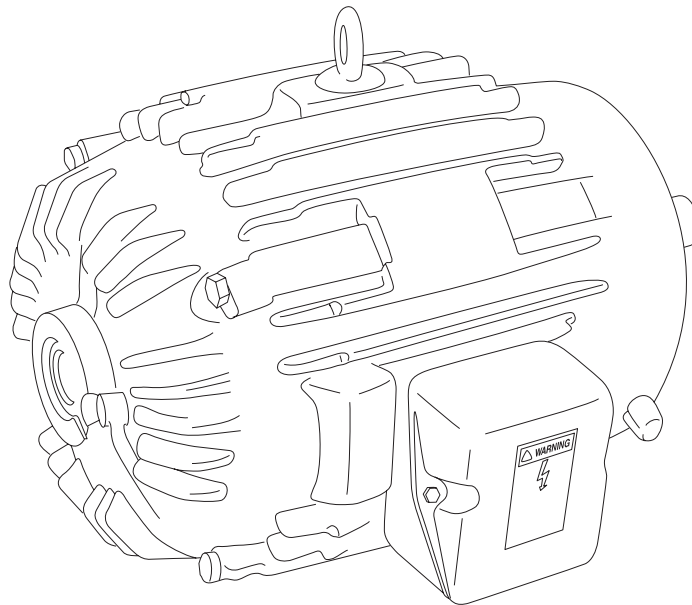

Totally Enclosed Fan Cooled (TEFC)

The totally enclosed fan-cooled motor is similar to the TENV except an external fan is mounted opposite the drive end of the motor. The fan provides additional cooling by blowing air over the exterior of the motor to dissipate heat more quickly. A shroud covers the fan to prevent anyone from touching it. With this arrangement no outside air enters the interior of the motor. TEFC motors can be used in dirty, moist, or mildly corrosive operating conditions. TEFC motors are more widely used for integral HP applications.

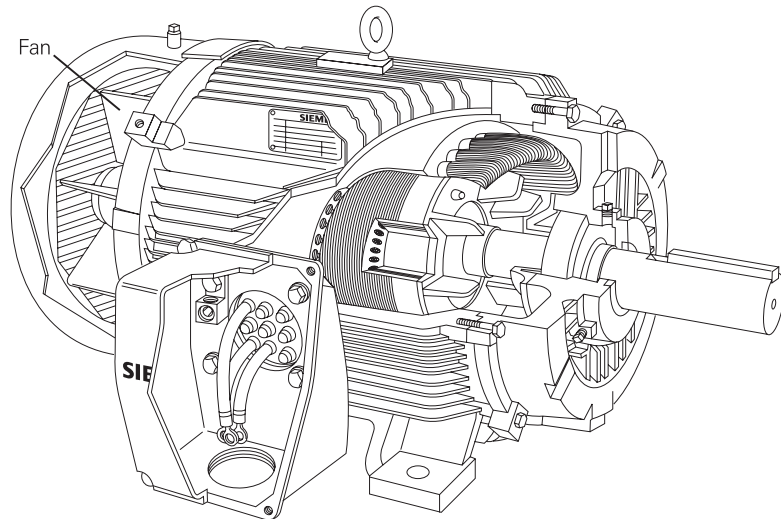

Explosion Proof (XP)

The explosion proof motor enclosure is similar in appearance to the TEFC, however, most XP enclosures are cast iron. The application of motors used in hazardous locations is subject to regulations and standards set by regulatory agencies such as the *National Electrical Code*® and Underwriters Laboratories for XP motors used in the United States.

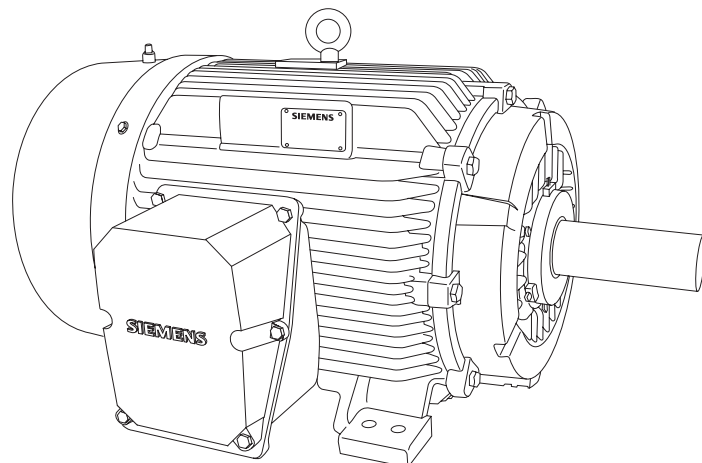

NEC® and *National Electrical Code*® are registered trademarks of the National Fire Protection Association.

Hazardous Environments

Although you should never specify or suggest the type of location, it is important to understand regulations that apply to hazardous locations. It is the user's responsibility to contact local regulatory agencies to define the location as Division I or II and to comply with all applicable codes. There are two divisions.

Division I

Hazardous materials are normally present in the atmosphere. A division I location requires an explosion proof motor.

Division II

Atmosphere may become hazardous as result of abnormal conditions. This may occur if, for example, a pipe breaks that is the conduit for a hazardous chemical.

Classes and Groups

Once the location is defined as hazardous the location is further defined by the class and group of hazard. Class I, Groups A through D are chemical gases or liquids such as gasoline, acetone, and hydrogen. Class II, Groups E, F, and G include flammable dust, such as coke or grain dust. Class III is not divided into groups. It includes all ignitable fibers and lints such as clothing fiber in textile mills.

Class I	Class II	Class III
Groups A-D Gasses and	Groups e-G Flammable Dust	Ignitable Fibers
Gasoline Acetone Hydrogen	Coke Dust Grain Dust Metallic Dust	Rayon Jute

In some cases it may be necessary for the user to define the lowest possible ignition temperature of the hazardous material to assure the motor complies with all applicable codes and requirements.

Mounting

NEMA Dimensions

NEMA has standardized frame size motor dimensions. Standardized dimensions include bolt hole size, mounting base dimensions, shaft height, shaft diameter, and shaft length. Existing motors can be replaced without reworking the mounting arrangement. New installations are easier to design because the dimensions are known. Letters are used to indicate where a dimension is taken. For example, the letter "C" indicates the overall length of the motor. The letter "E" represents the distance from the center of the shaft to the center of the mounting holes in the feet. The actual dimensions are found by referring to a table in the motor data sheet and referencing the letter to find the desired dimension.

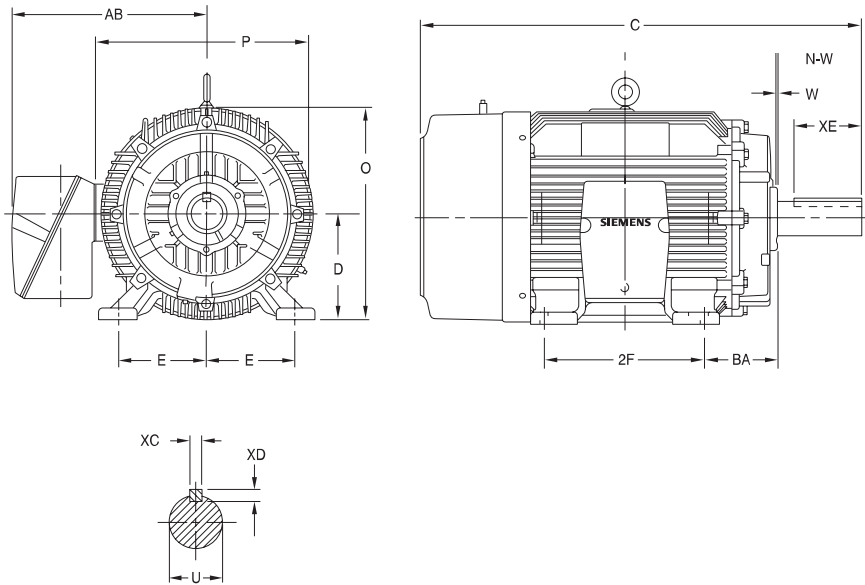

NEMA divides standard frame sizes into two categories: fractional and integral. Fractional frame sizes are designated 48 and 56 and include primarily horsepower ratings of less than one horsepower. Integral or medium horsepower motors are designated by frame sizes ranging from 143T to 445T. A "T" in the motor frame size designation of integral horsepower motors indicates the motor is built to current NEMA frame standards. Motors built prior to 1966 have a "U" in the motor frame size designation, indicated they are built to previous NEMA Standards.

143**T** = Current NEMA Standards

326**U** = Previous NEMA Standards

The frame size designation is a code to help identify key frame dimensions. The first two digits, for example, are used to determine the shaft height. The shaft height is the distance from the center of the shaft to the mounting surface. To calculate the shaft height divide the first two digits of the frame size by 4. In the following example a 143T frame size motor has a shaft height of 3½ inches ($14 \div 4$).

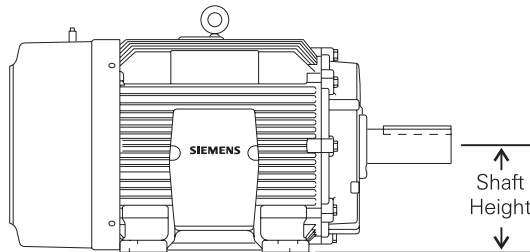

Frame **14**3T
↓
 $14 \div 4 = 3\frac{1}{2}$ "

The third digit in the integral “T” frame size number is the NEMA code for the distance between the center lines of the mounting bolt holes in the feet of the motor.

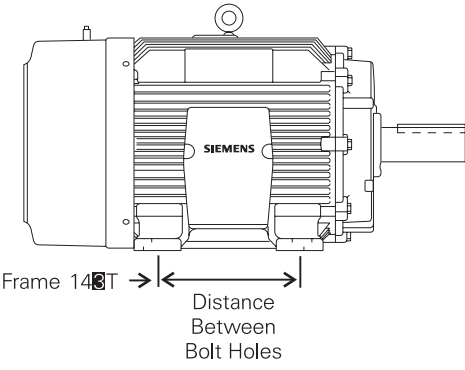

The dimension is determined by matching the third digit in the frame number with a table in NEMA publication MG-1. It can be seen that the distance between the center lines of the mounting bolt holes in the feet of a 143T frame is 4.00 inches.

Frame Number Series	D	Third/Fourth Digit In Frame Number				
		1	2	3	4	5
140				4.00	4.50	4.50
160	4.00	3.50	4.00	4.50	5.00	5.00
180	4.50	4.00	4.50	5.00	5.50	5.50
200	5.00	4.50	5.00	5.50	6.50	6.50
210	5.25	4.50	5.00	5.50	6.25	6.25
220	5.50	5.00	5.50	6.25	6.75	6.75
250	6.25	5.50	6.25	7.00	8.25	8.25
280	7.00	6.25	7.00	8.00	9.50	9.50
320	8.00	7.00	8.00	9.00	10.50	10.50

IEC Dimensions

IEC also has standardized dimensions which differ from NEMA. Many motors are manufactured using IEC dimensions. IEC dimensions are shown in the following drawing.

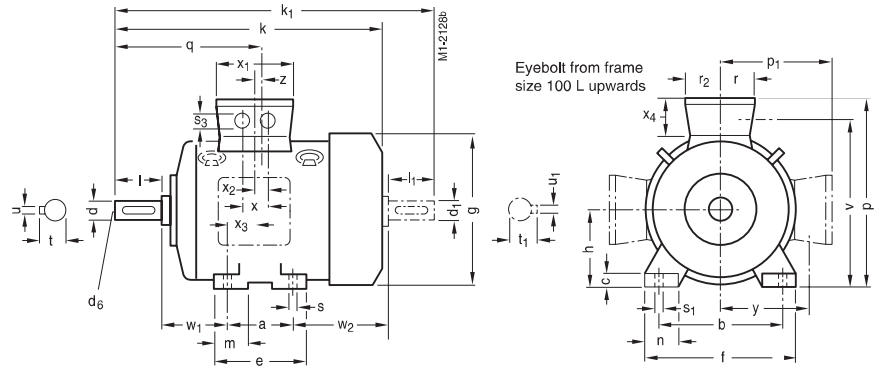

Mounting Positions

The typical floor mounting positions are illustrated in the following drawing, and are referred to as F-1 and F-2 mountings. The conduit box can be located on either side of the frame to match the mounting arrangement and position. The standard location of the conduit box is on the left-hand side of the motor when viewed from the shaft end. This is referred to as the F-1 mounting. The conduit opening can be placed on any of the four sides of the box by rotating the box in 90° steps.

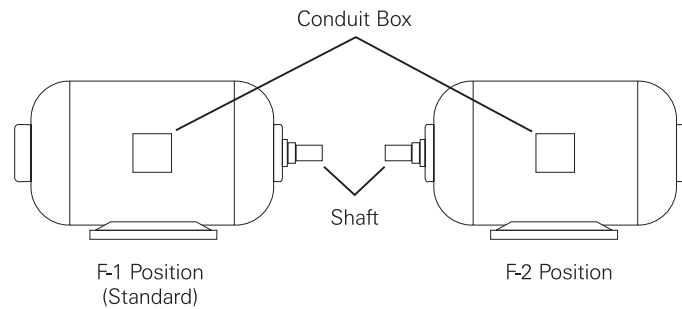

With modification the foot-mounted motor can be mounted on the wall and ceiling. Typical wall and ceiling mounts are shown in the following illustration. Wall mounting positions have the prefix "W" and ceiling mounted positions have the prefix "C."

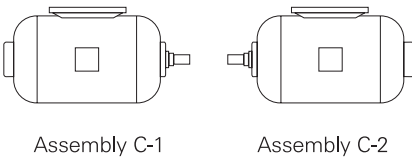
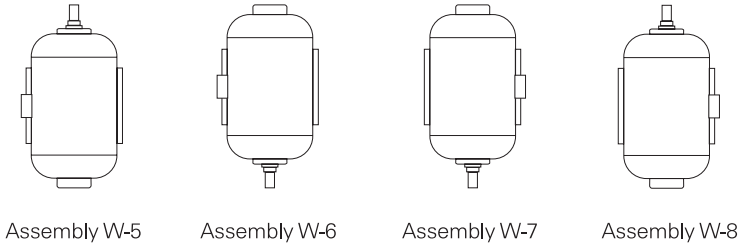
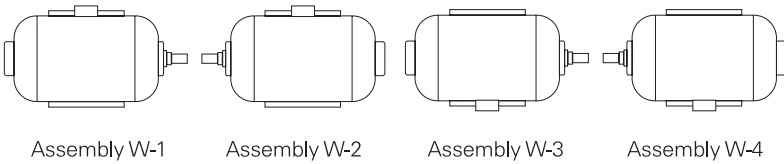

Mounting Faces

It is sometimes necessary to connect the motor directly to the equipment it drives. In the following example a motor is connected directly to a gear box.

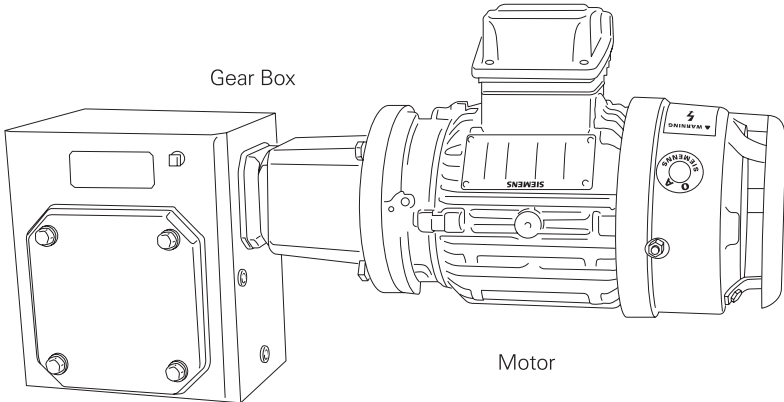

C-face

The face, or the end, of a C-face motor has threaded bolt holes. Bolts to mount the motor pass through mating holes in the equipment and into the face of the motor.

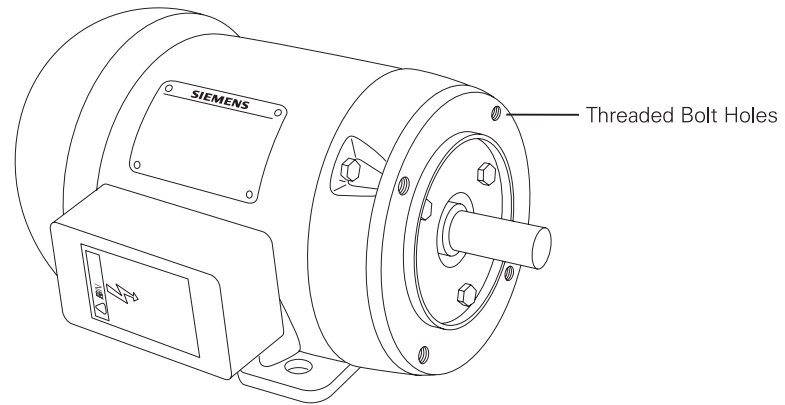

D-flange

The bolts go through the holes in the flange of a D-flange motor and into threaded mating holes of the equipment.

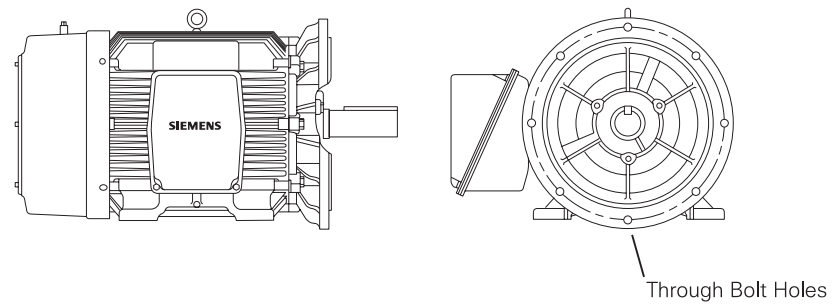

Review 7

1. A type of open enclosure that prevents liquids and solids falling from above at angles up to 15° from vertical from entering the interior of the motor is an _____ .
2. A type of enclosure that is closed and uses a fan mounted on the shaft to supply cooling is referred as _____ .
3. Gasoline is defined as a Class _____ hazard.
4. The NEMA dimension from the center of the shaft to the mounting surface is designated by the letter _____ .
5. The letter _____ in the motor frame size designation indicates a motor is built to current NEMA standards.
6. The shaft height can be determined by dividing the first two digits of an integral frame designation by _____ .
7. A motor intended to be mounted on the wall with the conduit box facing up and the shaft facing left is an Assembly _____ .
8. A _____ motor has threaded bolt holes to mount a motor to another piece of equipment.

Siemens Motors

Siemens manufactures a wide range of AC motors. The following information provides only an introduction to these motors. Contact your local Siemens representative for more information on any of the motors discussed or other Siemens AC motors.

Medallion™ Motors

Medallion motors represent the newer family of Siemens enclosed motors. Medallion EPACT efficiency motors are high performance motors designed to meet the requirements of the U.S. Energy Policy Act of 1992 (EPAct). EPACT efficiency motors are available from 1 to 200 HP in both ODP and TEFC enclosures. Depending on the specific motor, EPACT efficiency motors are wound for 900, 1200, 1800, or 3600 RPM when used on a 230 or 460 volt power supply. Premium efficiency Medallion motors are available from 1 to 400 horsepower. Depending on the specific motor, premium efficiency motors are wound for 900, 1200, 1800, or 3600 RPM when used on a 230/460 (460 only above 20 HP) volt power supply. EPACT and premium efficiency motors are also available for use on other voltage sources such as 575 volt systems. Contact your Siemens representative for information and lead times.

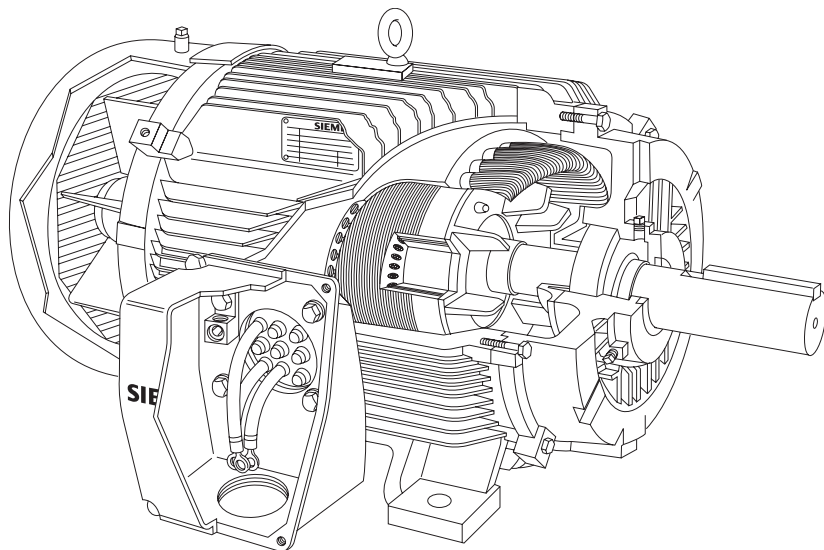

Medallion motors are available with longer shafts for belt driven applications and vertical mounting for applications such as pumps. Various protective devices, such as thermocouples and thermistors, can be installed as an option. These devices are wired into the motor controller and shut down the motor if temperature becomes excessive. Space heaters can also be used to keep the temperature of the motor above the dew point in areas that are damp or humid. Space heaters are turned off when the motor is running and on when the motor is stopped.

Medallion motors are also available in two-speed configurations. A two-speed motor often has two sets of windings, each wound with a different number of poles. The windings are brought out to an external controller. The motor can be run at either speed. Typical speed selections are 900 or 1200 RPM at low speed, and 1800 RPM at high speed.

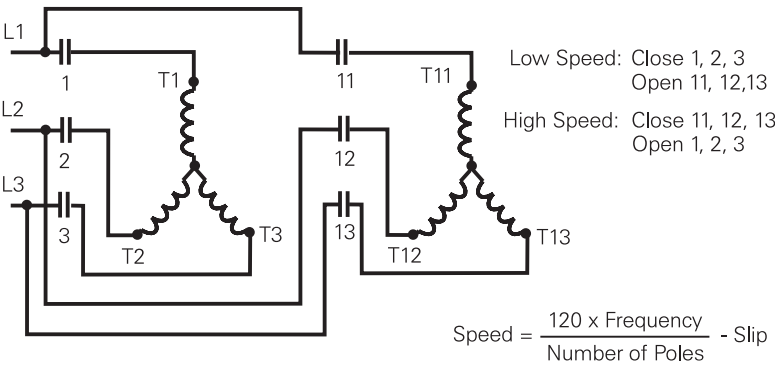

PE-21 Plus™ Motors

PE-21 Plus motors are premium efficiency motors available from 1 to 500 HP. Premium efficiency motors typically cost slightly more than standard efficiency motors, but payback is in energy savings.

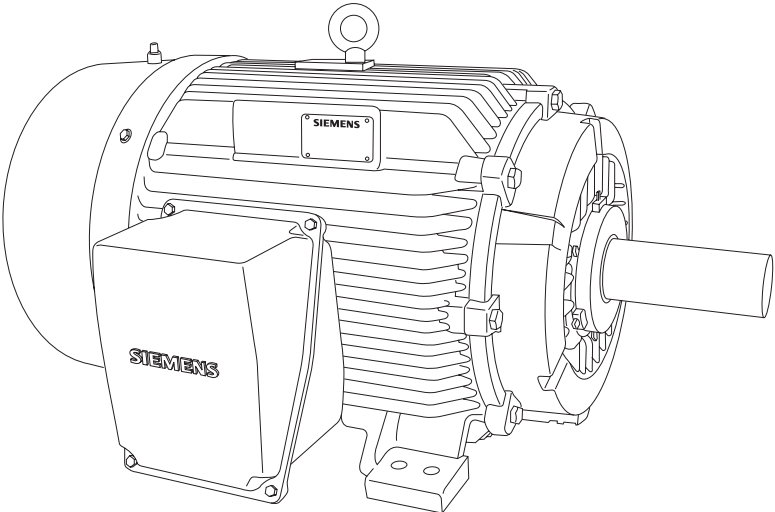

The following example is used to show energy savings available over the life of a premium efficiency motor. A 25 HP motor (Motor 1) with an efficiency of 86.5% costing \$590, and a PE-21 Plus with an efficiency of 93% costing \$768 are compared. Using a process life of 60,000 hours at \$.08 a kilowatt hour, the PE-21 Plus will save \$7,055 in total operating cost.

$$CL = P_i + \frac{.746 \times HP \times T_o \times R_u}{E}$$

CL Lifetime motor operating cost
 P_i Initial price of motor
 HP Motor horsepower
 T_o Lifetime hours of operation
 R_u Local utility rates - (\$/KWH)
 E Motor nameplate efficiency

Example:

25 HP, 1800 RPM, TEFC

Motor 1 F/L Eff. 86.5%
 Motor 1 P_i \$590

PE-21 Plus Eff. 93.0%
 PE-21 Plus P_i \$768

Motor 1

$$CL = 590 + \frac{.746 \times 25 \times 60,000 \times .08}{86.5}$$

CL = \$104,081

PE-21 Plus Motor

$$CL = 768 + \frac{.746 \times 25 \times 60,000 \times .08}{93.0}$$

CL = \$97,026

Savings = \$7,055

Vertical Pump Motors

Vertical hollow shaft pump motors are designed for vertical pump applications. The motors are squirrel cage induction type with NEMA design B torque and current characteristics. Motors are rated from 25 to 250 HP and 1800 RPM. Vertical pump motors are designed for 460 volt, 3-phase, 60 Hz systems. Thermostats and space heaters are optional.

These motors have NEMA standard P flange mounting shaft with a hollow shaft which accommodates the driven shaft to extend through the rotor. The coupling for connecting the motor shaft to the driven shaft is located in the top of the motor.

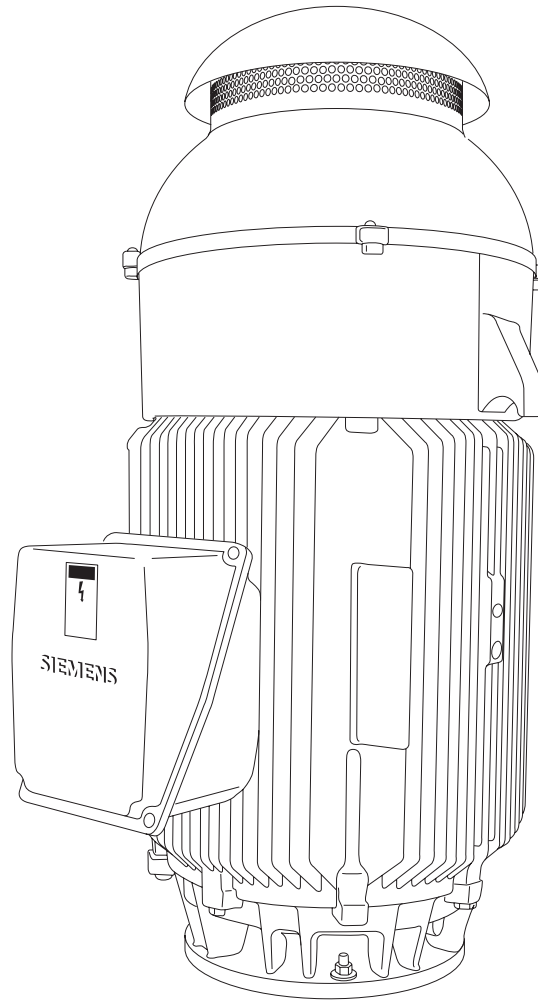

In addition to hollow shaft, more conventional solid shaft motors are supplied where the motor shaft is coupled to the driven shaft below the P flange face. Vertical solid shaft motors designed for in-line pump applications are available from 3 - 100 HP at 3600 RPM, and 3 - 250 HP at 1200 and 1800 RPM.

IEC Motors

IEC motors are manufactured to meet specifications of the International Electrotechnical Commission, IEC 34. Standard voltages at 50 Hz are 220, 400, 500, or 660 volts. Standard voltage at 60 Hz is 460 volts. Siemens IEC motors are available with 2, 4, 6, and 8 poles. IEC motors are also available for multispeed applications. Siemens IEC motors are available from 0.12 KW (0.16 HP) to 630 KW (840 HP).

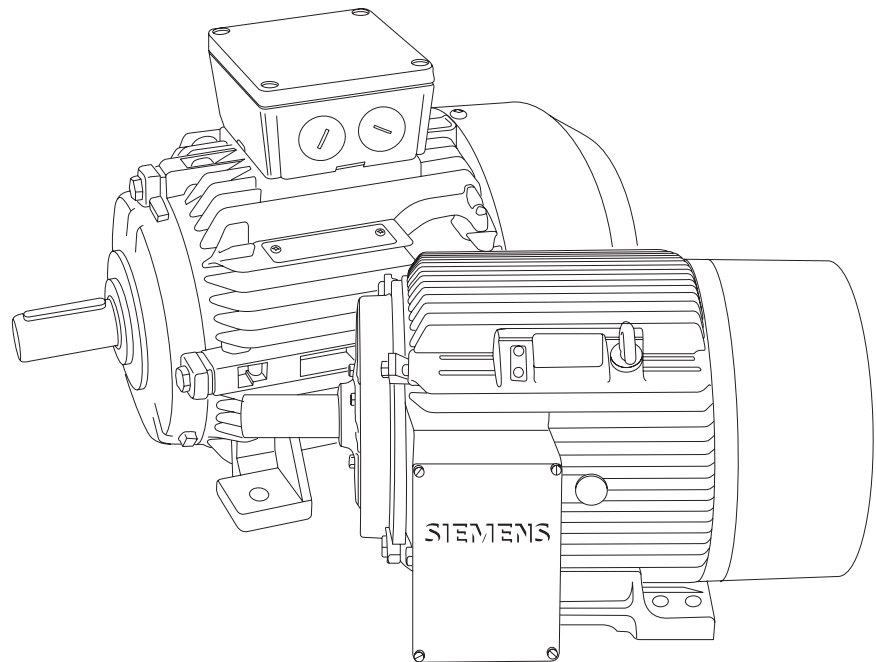

While mounting flange dimensions, shaft height, shaft extensions, and other performance standards clearly differ with comparable NEMA motors, a closer comparison will show remarkably similar characteristics. Perhaps the greatest obstacle to working with IEC motors is familiarity with unique terminology and the ability to correlate with more familiar NEMA standards.

Above NEMA Motors

Motors that are larger than the NEMA frame sizes are referred to as above NEMA motors. These motors typically range in size from 200 to 10,000 HP. Some above NEMA motors manufactured by Siemens may also be considered Medallion™ motors. There are no standardized frame sizes or dimensions because above NEMA motors are typically constructed to meet the specific requirements of an application. Siemens offers large motors in nine basic frame size series: 30, 500, 580, 680, 708, 788, 800, 880, and 1120 frames. For each frame size Siemens has standard frame dimensions similar to NEMA dimensions. For specific application information contact your local Siemens representative.

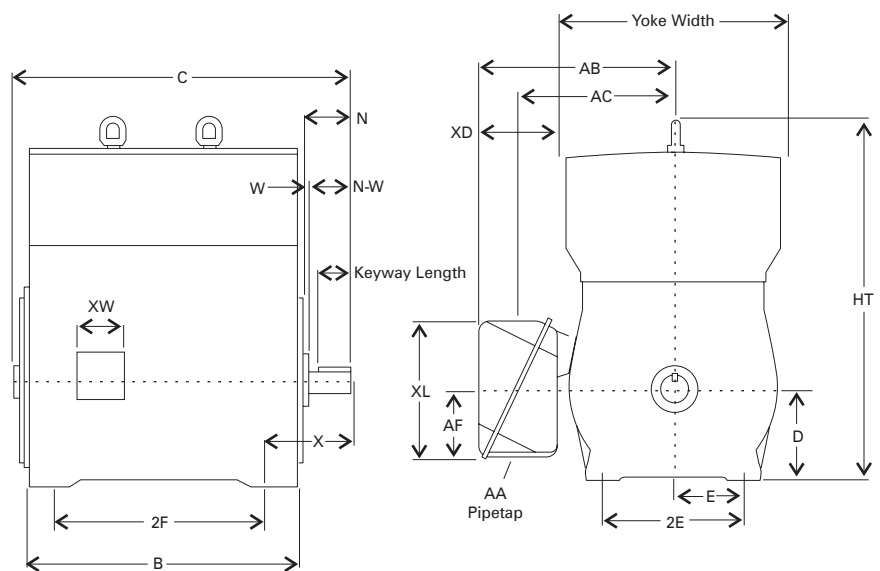

The customer typically supplies specifications for starting torque, breakdown torque, and full-load torque based on speed-torque curves obtained from the driven equipment manufacturer. There are, however, some minimum torques that all large AC motors must be able to develop. These are specified by NEMA.

Locked Rotor Torque $\geq 60\%$ of Full-Load Torque
Pull-Up Torque $\geq 60\%$ of Full-Load Torque
Maximum Torque $\geq 175\%$ of Full-Load Torque

Above NEMA motors require the same adjustment for altitude and ambient temperature as integral frame size motors. When the motor is operated above 3300 feet a higher class insulation should be used or the motor should be derated. Above NEMA motors with class B insulation can easily be modified for operation in an ambient temperature between 40° C and 50° C. Above 50° C requires special modification at the factory.

Enclosures

Environmental factors also affect large AC motors. Enclosures used on above NEMA motors look differently than those on integral frame size motors.

Open Drip Proof (ODP) (Type CG)

Open drip proof enclosures provides the same amount of protection as the integral frame size open motor. This provides the least amount of protection for the motor's electrical components. ODP enclosures are used on indoor applications in environments free of contaminants. This enclosure is available up to 10,000 HP.

Weather Protected I (WPI) (Type CG)

The weather protected I enclosure is an open enclosure that has ventilating passages designed to minimize the entrance of airborne particles that could come into contact with the electrical and rotating parts of the motor. All air inlets and exhaust vents are covered with screens. It is used on indoor applications either free of or containing minimal contaminants. This enclosure is available to 10,000 horsepower.

ODP and WPI Enclosures

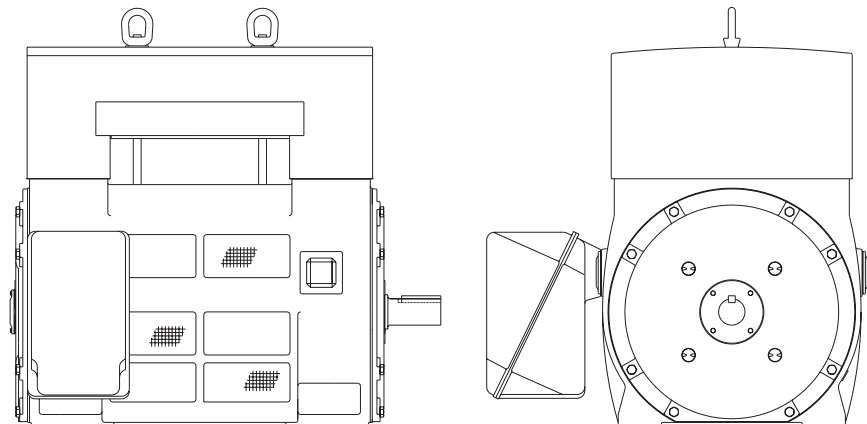

580, 680, and 800 Frames

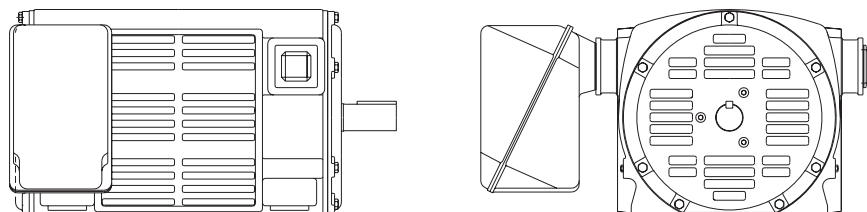

500 Frame

**Weather Protected II (WP/II)
(Type CG/II)**

Weather protected II enclosures are open enclosures with vents constructed so that high velocity air and airborne particles blown into the motor can be discharged without entering the internal ventilating passages leading to the electrical parts of the motor. The intake and discharge vents must have at least three 90° turns and the air velocity must be less than 600 feet per minute. It is used on outdoor applications when the motor is not protected by other structures. This enclosure is available up to 10,000 horsepower.

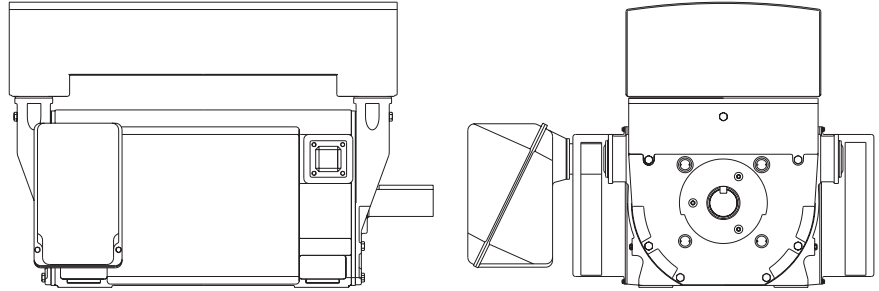

Totally Enclosed Fan Cooled (Type CZ and CGZ)

The totally enclosed fan cooled motor functions the same as the TEFC enclosure used on integral frame size motors. It is designed for indoor and outdoor applications where internal parts must be protected from adverse ambient conditions. Type CZ and CGZ utilize cooling fins both all around the yoke and the bearing housings. This enclosure is available up to 600 HP on 500 frames, 900 horsepower on 580 frames, and 2250 horsepower on 708-880 frames.

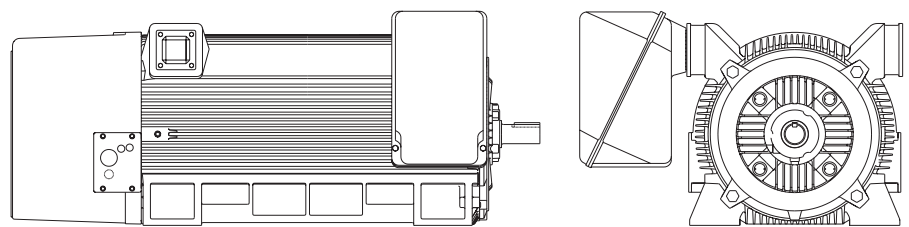

Totally Enclosed Air to Air Cooled (Type TEAAC) (Type CAZ)

Type TEAAC totally enclosed motor utilize air to tube type heat exchangers for cooling. This enclosure is available up to 7,000 HP.

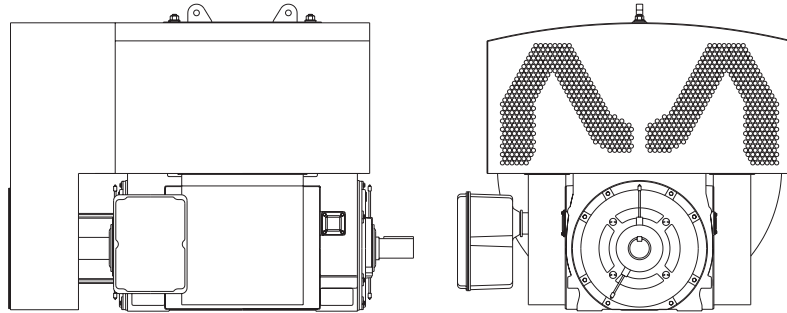

Totally Enclosed Water Cooled (TEWAC) (Type CGG)

There comes a point when the motor frame cannot adequately dissipate heat, even with the help of a fan. This enclosure is designed to cool the motor by means of a water-to-air heat exchanger. This type of enclosure requires a steady supply of water. This enclosure is available up to 10,000 HP.

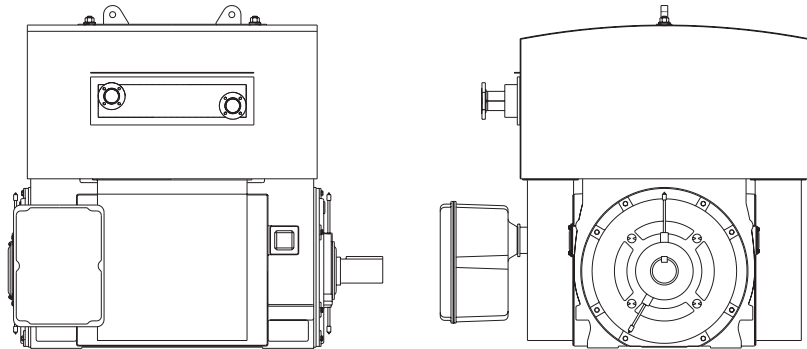

Totally Enclosed Fan Cooled Explosion Proof (TEFC-XP) (Type CGZZ and AZZ)

Large AC motors are also used in hazardous environments. This enclosure meets or exceeds all applicable UL requirements for hazardous (Division 1) environmental operation. This enclosure is available up to 1750 HP.

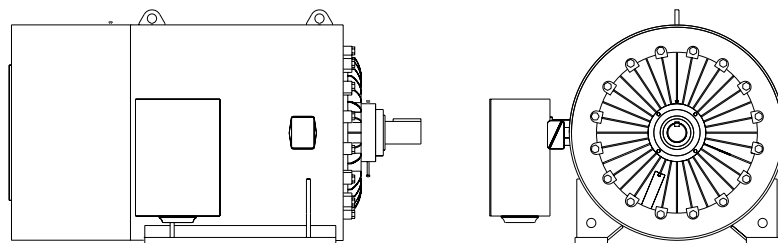

Review 8

1. TEFC EPACT efficiency Medallion motors are available from 1 to _____ horsepower.
2. PE-21 Plus motors are available from 1 to _____ horsepower.
3. An advantage of a premium efficiency motor over a standard efficiency motor is a savings in _____ over the operating life of the motor.
4. Vertical pump motors have NEMA design _____ torque and current characteristics.
5. IEC motors are built to IEC _____ standards.
6. Above NEMA motors are available from _____ to _____ HP.
7. Locked rotor torque of an above NEMA motor is \geq _____ % of full-load torque.

Review Answers

- Review 1** 1) force; 2) 15; 3) torque; 4) 80; 5) inertia; 6) Speed; 7) revolutions per minute; 8) Acceleration
- Review 2** 1) A. enclosure, B. stator, C. rotor; 2) stator and rotor; 3) stator; 4) rotor; 5) squirrel cage
- Review 3** 1) north, south; 2) A. attract, B. repel, C. repel D. attract; 3) magnetic field; 4) D
- Review 4** 1) 2, north; 2) synchronous; 3) 1800; 4) slip; 5) 4.2
- Review 5** 1) 34.5; 2) 105°C; 3) 150; 4) Breakdown
- Review 6** 1) 10; 2) 188; 3) 7.67; 4) 1.15; 5) 40
- Review 7** 1) open drip proof; 2) totally enclosed fan cooled; 3) I; 4) D; 5) T; 6) 4; 7) W-2; 8) C-face
- Review 8** 1) 200; 2) 500; 3) energy; 4) B; 5) 34; 6) 200 to 10,000; 7) 60

Final Exam

The final exam is intended to be a learning tool. The book may be used during the exam. A tear-out answer sheet is provided. After completing the test, mail the answer sheet in for grading. A grade of 70% or better is passing. Upon successful completion of the test a certificate will be issued.

1. _____ is a twisting or turning force that causes an object to rotate.
 - a. Torque
 - b. Friction
 - c. Inertia
 - d. Acceleration

2. If 50 pounds of force were applied to a lever 3 feet long, the torque would be _____ Lb-Ft.
 - a. 16.7
 - b. 53
 - c. 47
 - d. 150

3. The rate of doing work is called _____ .
 - a. inertia
 - b. speed
 - c. power
 - d. energy

4. A motor with a rating of 60 KW would have an equivalent rating of _____ HP.
 - a. 45
 - b. 80
 - c. 65
 - d. 120

5. Three basic parts of an AC motor are the _____ .
 - a. rotor, stator, and enclosure
 - b. shaft, housing, and connection box
 - c. cooling fan, rotor, and stator
 - d. end brackets, bearings and cooling fan

6. A four-pole motor operating at 50 Hz has a synchronous speed of _____ RPM.
 - a. 1500
 - b. 3000
 - c. 1800
 - d. 3600

15. The following graph represents a NEMA _____ motor.

- a. A
- b. B
- c. C
- d. D

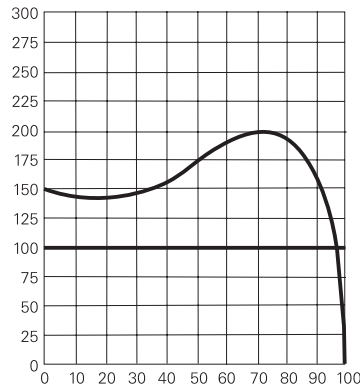

16. A _____ motor enclosure uses vent openings to prevent liquids and solids falling from above at angles from up to 15° from vertical from entering the interior of the motor.

- a. TENV
- b. XP
- c. TEFC
- d. ODP

17. Grain dust is in a hazardous location Class _____ .

- a. II
- b. III
- c. A
- d. C

18. The letter _____ in the motor frame size designation of an integral horsepower motor indicates the motor is built to current NEMA standards.

- a. C
- b. U
- c. T
- d. N

19. The shaft height of a 449 frame integral horsepower motor is _____ inches.

- a. 3½
- b. 9
- c. 4.4
- d. 11

20. PE-21 Plus™ motors are available from 1 to _____ HP.

- a. 500
- b. 1200
- c. 800
- d. 2500

quickSTEP Online Courses

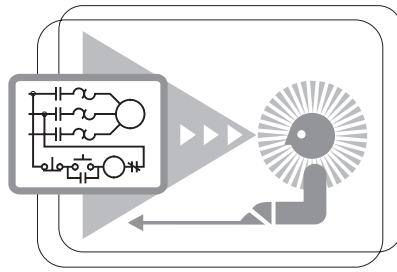

quickSTEP online courses are available at <http://www.sea.siemens.com/step>.

The quickSTEP training site is divided into three sections: Courses, Downloads, and a Glossary. Online courses include reviews, a final exam, the ability to print a certificate of completion, and the opportunity to register in the Sales & Distributor training database to maintain a record of your accomplishments.

From this site the complete text of all STEP 2000 courses can be downloaded in PDF format. These files contain the most recent changes and updates to the STEP 2000 courses.

A unique feature of the quickSTEP site is our pictorial glossary. The pictorial glossary can be accessed from anywhere within a quickSTEP course. This enables the student to look up an unfamiliar word without leaving the current work area.

